

# CD-100K LASERSTAR® STARGLO

FIELD SERVICE MANUAL  
& PARTS CATALOG

**VOLUME 1 of 2**  
INSTALLATION, PROGRAMMING,  
ROUTINE SERVICE

Part No. 21822666  
Rev. C

# CD-100K LASERSTAR® STARGLO

FIELD SERVICE MANUAL & PARTS CATALOG  
VOLUME 1

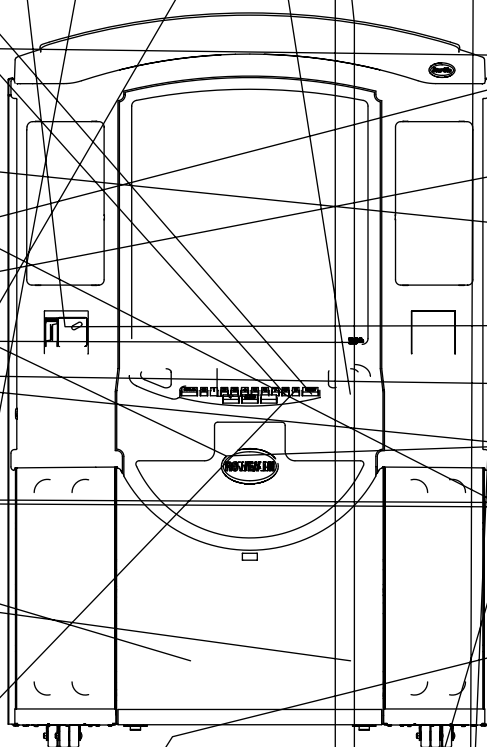

Rowe International, Inc.  
1500 Union SE • Grand Rapids, MI 49507-1884  
(616) 243-3633

Printed in USA

This page intentionally left blank.

## Preface

To make installation easier, this manual describes a typical installation. This “typical” installation only includes loading the title rack and discs, setting up the sound system, and in some situations, modifying the pricing.

If you wish to make further programming changes, make them using the information that follows the basic installation.

This manual is divided into two parts. Volume 1 (Sections 1-3) contains routine installation and service information. Volume 2 (Sections 4-8) contains troubleshooting charts, schematics, and other maintenance information. Please take time to read this page and review the *Table of Contents* in both volumes.

The *Troubleshooting* section includes schematics, component lists, and board layouts for all serviceable modules.

This service manual is divided into eight sections:

### **Volume 1**

**Section 1 System Description**—Introduces you to the CD-100K, its features, and its major components, principles of operation, and step-by-step unpacking instructions. After unpacking the CD-100K, you should continue the installation process by following the title rack loading and programming instructions in *Section 2*.

**Section 2 Installation and Programming**—Continues the installation process with disc and title rack loading instructions, programming references, and step-by-step programming and pricing instructions. Whether you are familiar with previous Rowe phonographs or not, pay special attention to the pricing and programming.

Programming and pricing have been set at the factory, so you may not wish to change any of the CD-100K options. After you load the titles and the discs, the CD-100K is ready to play.

**Section 3 Routine Service**—Provides routine service instructions for collecting money, doing cash and play audits, resetting phonograph totals, and doing preventive maintenance.

### **Volume 2**

**Section 4 LED Lighting**—

**Section 5 Troubleshooting**—Provides troubleshooting charts, error code and disc condition descriptions, troubleshooting procedures, wiring diagrams, and diagnostic LED descriptions.

**Section 6 Mechanical Adjustments**—Details the mechanical checks and adjustment procedures for all of the CD-100K modules.

**Section 7 Miscellaneous**—Contains specifications, fuse and circuit breaker locations, and a resistor color code chart.

**Section 8 The Parts Catalog**—Lists and illustrates all replaceable modules in the CD-100K. The Accessory Equipment List is at the end of this section.

This manual is intended for owners, route operators, and technicians. It provides all field and shop related service and maintenance material. Accessories and their installation and service are discussed in the corresponding accessory instructions (or manuals).

## Table of Contents

### **SECTION 1 — INSTALLATION AND SYSTEM DESCRIPTION**

|  |            |
|--|------------|
| <b>Introduction</b> .....                      | <b>1-1</b> |
| <b>Features</b> .....                          | <b>1-2</b> |
| General Features .....                         | 1-2        |
| Service Features .....                         | 1-2        |
| <b>Unpacking Instructions</b> .....            | <b>1-3</b> |
| Exterior .....                                 | 1-3        |
| Doors .....                                    | 1-3        |
| Shipping Bolts, Clips, and Tape .....          | 1-4        |
| Title Page Assembly .....                      | 1-4        |
| Mechanism .....                                | 1-5        |
| CD Unpacking .....                             | 1-5        |
| <b>Visual Inspection</b> .....                 | <b>1-6</b> |
| <b>Phonograph Leveling</b> .....               | <b>1-6</b> |
| <b>Handy Case</b> .....                        | <b>1-6</b> |
| <b>Warranty Registration Card</b> .....        | <b>1-6</b> |
| <b>Major Components of the CD-100K</b> .....   | <b>1-6</b> |
| CD Selection System .....                      | 1-7        |
| Keyboard .....                                 | 1-7        |
| Central Control Computer .....                 | 1-7        |
| Memorec .....                                  | 1-7        |
| Autoplay .....                                 | 1-8        |
| <b>Principles of Operation</b> .....           | <b>1-8</b> |
| Audio System .....                             | 1-8        |
| CD Player .....                                | 1-8        |
| Stereo Preamp .....                            | 1-8        |
| Stereo Amplifier .....                         | 1-8        |
| Two-Wire Volume Control .....                  | 1-9        |
| Output Transformers .....                      | 1-9        |
| Speaker System .....                           | 1-9        |
| CD Changer Mechanism .....                     | 1-10       |
| Magazine .....                                 | 1-10       |
| Play Counter .....                             | 1-10       |
| Money Counter .....                            | 1-10       |
| Optical Switch .....                           | 1-10       |
| Cam Switch and Motor Assembly .....            | 1-11       |
| Sprag Assembly .....                           | 1-11       |
| CD Modules .....                               | 1-11       |
| Mechanism Control Unit .....                   | 1-12       |
| Main Power Supply .....                        | 1-12       |
| Lighting and Bill Acceptor Power Control ..... | 1-12       |

### **SECTION 2 — INSTALLATION & PROGRAMMING**

|   |            |
|---|------------|
| <b>Introduction</b> .....                   | <b>2-1</b> |
| <b>Power On</b> .....                       | <b>2-1</b> |
| <b>Loading CD's and Titles</b> .....        | <b>2-2</b> |
| Preparing Titles For The Title Holder ..... | 2-2        |
| Loading the Title Holder .....              | 2-3        |

## Table of Contents

### **SECTION 2 — INSTALLATION & PROGRAMMING** *(Continued)*

|   |             |
|---|-------------|
| <b>Procedures for Loading the Title Page Holder .....</b> | <b>2-4</b>  |
| <b>Procedures for Loading Discs .....</b>                 | <b>2-5</b>  |
| <b>Setting Title Page Limits for the First Time .....</b> | <b>2-7</b>  |
| <b>Pricing .....</b>                                      | <b>2-7</b>  |
| To Set Disc Prices .....                                  | 2-8         |
| How CD-100K Pricing Works .....                           | 2-8         |
| Sample Price Changes .....                                | 2-8         |
| Checking the Pricing .....                                | 2-10        |
| <b>Sound System Setup .....</b>                           | <b>2-10</b> |
| Extension Speaker Operation .....                         | 2-10        |
| 70-Volt Speakers .....                                    | 2-11        |
| Low Impedance Speakers .....                              | 2-11        |
| <b>Selecting Speaker Power .....</b>                      | <b>2-12</b> |
| General Instructions .....                                | 2-12        |
| Selection Procedures .....                                | 2-12        |
| 4-Ohm Speakers .....                                      | 2-13        |
| 8-Ohm Speakers .....                                      | 2-14        |
| 70-Volt Speakers .....                                    | 2-14        |
| <b>Transformer Wiring Diagram .....</b>                   | <b>2-20</b> |
| <b>Speaker Synopsis .....</b>                             | <b>2-22</b> |
| <b>IR Volume Control 2CH Preamp .....</b>                 | <b>2-29</b> |
| Single Volume Control Setup .....                         | 2-29        |
| Dual Volume Control Setup .....                           | 2-29        |
| <b>Sound System .....</b>                                 | <b>2-30</b> |
| Acoustical Compensation (Equalizer Tone Controls) .....   | 2-30        |
| What This Graphic Equalizer Does .....                    | 2-30        |
| Equalizer Settings .....                                  | 2-30        |
| If the Room or Speaker System Requires a Trade-Off .....  | 2-31        |
| Procedures for Adjustment .....                           | 2-31        |
| Soft and Highly Absorbent Rooms .....                     | 2-31        |
| Average or Moderately-Absorbent Rooms .....               | 2-32        |
| Hard and Non-Absorbent Rooms .....                        | 2-32        |
| Paging .....  | 2-33        |
| <b>Changing the Number of Credits Remaining .....</b>     | <b>2-33</b> |
| <b>Entering the Service Mode .....</b>                    | <b>2-33</b> |
| <b>Viewing Menus .....</b>                                | <b>2-33</b> |
| If You "Get Lost" in the Menus .....                      | 2-34        |
| <b>Using CD-100K Commands .....</b>                       | <b>2-34</b> |
| Combining Menu and Command Modes .....                    | 2-34        |
| Service Mode Menu .....                                   | 2-38        |
| Security Menu .....                                       | 2-38        |
| Modem Menu .....  | 2-38        |
| Audits Menu .....   | 2-38        |
| Attract Mode Menu .....                                   | 2-38        |
| Message Center Menu .....                                 | 2-38        |
| Initialize Menu .....                                     | 2-38        |
| Autoplay .....  | 2-39        |
| Pricing Menu .....  | 2-39        |

## Table of Contents

### **SECTION 2 — INSTALLATION & PROGRAMMING** *(Continued)*

|   |              |
|---|--------------|
| Options Menu .....  | 2-39         |
| More Options 1 Menu .....   | 2-40         |
| More Options 2 Menu .....   | 2-40         |
| Reports Menu (Optional) .....   | 2-40         |
| Status Menu .....   | 2-40         |
| Remote Menu (Optional) .....  | 2-40         |
| <b>How To Make Programming Changes .....</b>                              | <b>2-41</b>  |
| Keyboard Controls .....   | 2-41         |
| Security Levels .....   | 2-42         |
| Factory Security Level .....  | 2-42         |
| Loading Factory Settings .....  | 2-42         |
| <b>Programming Autoplay, Premiums, Priorities, and Lockouts .....</b>     | <b>2-76</b>  |
| <b>Autoplay Programming Modes .....</b>                                   | <b>2-77</b>  |
| <b>Lockout and Timed Lockout Modes .....</b>                              | <b>2-78</b>  |
| <b>Editing Autoplay, Premiums, Priorities, and Lockouts .....</b>         | <b>2-78</b>  |
| <b>Timed Free Play and Timed Lockout Scheduling Tutorial .....</b>        | <b>2-78</b>  |
| What Multiple Lockout On/Off Times Do .....                               | 2-78         |
| What Multiple Freeplay On/Off Times Do .....                              | 2-78         |
| <b>Rowe Phonograph Message Center .....</b>                               | <b>2-81</b>  |
| Inserting or Changing Messages .....                                      | 2-82         |
| Setting the Daily Message Display Time(s) .....                           | 2-86         |
| Setting the Master On/Off Date .....                                      | 2-88         |
| <b>Enhanced Autoplay Tutorial .....</b>                                   | <b>2-88</b>  |
| Autoplay .....  | 2-88         |
| Differences Between Standard and Enhanced Autoplay .....                  | 2-88         |
| <b>Setting Up Enhanced Autoplay .....</b>                                 | <b>2-89</b>  |
| Using RESET + 9 in the Category Menu .....                                | 2-92         |
| Disc Mode .....   | 2-92         |
| Category Mode .....   | 2-92         |
| Day Of The Week .....   | 2-93         |
| Event .....   | 2-93         |
| Time .....  | 2-93         |
| Categories .....  | 2-93         |
| Delay .....   | 2-93         |
| Channel 1 and Channel 2 Volume (Optional) .....                           | 2-93         |
| <b>Working Example of Enhanced Autoplay .....</b>                         | <b>2-94</b>  |
| <b>Optional Studio Sound System .....</b>                                 | <b>2-101</b> |
| <b>Introduction .....</b>   | <b>2-101</b> |
| <b>Volume Control Unit .....</b>  | <b>2-101</b> |
| <b>Audio/Video Controller .....</b>                                       | <b>2-102</b> |
| <b>BGM, Autoplay, and Paid Play Volume .....</b>                          | <b>2-102</b> |
| <b>Karaoke Controls .....</b>   | <b>2-102</b> |
| <b>Amplifier Factory Load .....</b>                                       | <b>2-103</b> |
| Other Configurations .....  | 2-103        |
| Summary of Audio/Video Controller Features and Flow – Front to Back ..... | 2-103        |

## Table of Contents

### **SECTION 3 — ROUTINE SERVICE**

|   |             |
|---|-------------|
| <b>Introduction</b> .....                   | <b>3-1</b>  |
| <b>Doing an Audit</b> .....                 | <b>3-1</b>  |
| <b>Collecting Audit Figures</b> .....       | <b>3-1</b>  |
| Entering the Service Mode .....             | 3-1         |
| Cash Audits .....                           | 3-2         |
| Play Audits .....                           | 3-2         |
| Non-Resettable Audits .....                 | 3-2         |
| Most Popular Disc .....                     | 3-2         |
| Least Popular Disc .....                    | 3-2         |
| Most Popular Selection .....                | 3-3         |
| Clearing the Audit Values .....             | 3-3         |
| Clear Cash .....                            | 3-3         |
| Clear Plays .....                           | 3-3         |
| Clear Selection Popularity .....            | 3-3         |
| <b>Changing CD's and Titles</b> .....       | <b>3-4</b>  |
| Preparing Titles for the Title Holder ..... | 3-4         |
| Changing Discs .....                        | 3-4         |
| <b>Complete Audit Command List</b> .....    | <b>3-6</b>  |
| <b>Collecting Money</b> .....               | <b>3-10</b> |
| <b>Preventive Maintenance</b> .....         | <b>3-10</b> |
| CD Player Laser Lens .....                  | 3-11        |
| <b>Coin Acceptors (Optional)</b> .....      | <b>3-12</b> |
| <b>Coin Mech (Optional)</b> .....           | <b>3-12</b> |

### **FREQUENTLY USED FIGURES AND TABLES**

#### **Volume 1**

|  |           |
|--|-----------|
| Extension Speaker Worksheet ( <i>Table 2-1</i> ) .....                   | 2-12      |
| Amplifier Overload Check ( <i>Table 2-2B</i> ) .....                     | 2-16      |
| Speaker Connections ( <i>Figure 2-7</i> ) .....                          | 2-18,2-19 |
| Volume & Cancel Control Diagrams ( <i>Figure 2-8</i> ) .....             | 2-28      |
| Service Mode Map ( <i>Figure 2-10</i> ) .....                            | 2-36      |
| Keyboard Controls ( <i>Table 2-4</i> ) .....                             | 2-41      |
| Menu and Command Descriptions ( <i>Table 2-5A and Table 2-5B</i> ) ..... | 2-43      |
| Command Index ( <i>Table 2-5</i> ) .....                                 | 2-69      |
| Audit Commands ( <i>Table 3-1</i> ) .....                                | 3-6       |



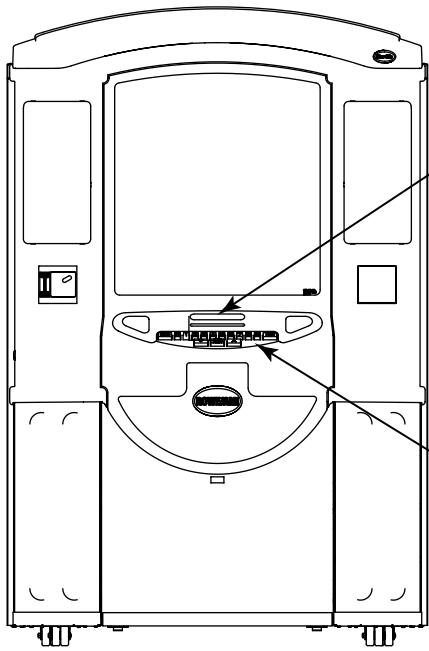

**Digital Display**  
Shows the Selection Playing,  
Selection Being Made, Selections  
Remaining, the Message Center,  
and Service Mode Display

**Selector Keyboard**  
Enters Numbers  
Contains the POPULAR,  
RESET, MY SONG FIRST,  
and Page Turning Keys

**Figure 1-1. CD-100K Major Components**





## IMPORTANT SAFETY INSTRUCTIONS

- 1) Read these instructions.
- 2) Keep these instructions.
- 3) Heed all warnings.
- 4) Follow all instructions.
- 5) Do not use this apparatus near water.
- 6) Clean only with a dry cloth.
- 7) Do not block any ventilation openings. Install in accordance with the manufacturer's instructions.
- 8) Do not install near any heat sources such as radiators, heat registers, stoves, or other apparatus (including amplifiers) that produce heat.
- 9) Do not defeat the safety purpose of the polarized or grounding-type plug. A polarized plug has two blades with one wider than the other. A grounding type plug has two blades and a third grounding prong. The wide blade or the third prong are provided for your safety. If the provided plug does not fit into your outlet, consult an electrician for replacement of the obsolete outlet.
- 10) Protect the power cord from being walked on or pinched, particularly at plugs, convenience receptacles, and the point where they exit from the apparatus.
- 11) Only use the attachments/accessories specified by the manufacturer.
- 12) Use only with the cart, stand, tripod, bracket, or table specified by the manufacturer or sold with the apparatus. When a cart is used, use caution when moving the cart/apparatus combination to avoid injury from tip-over.
- 13) Unplug this apparatus during lightning storms or when unused for long periods of time.
- 14) Refer all servicing to qualified service personnel. Servicing is required when the apparatus has been damaged in any way, such as when the power-supply cord or plug is damaged, liquid has been spilled or objects have fallen into the apparatus, the apparatus has been exposed to rain or moisture, does not operate normally, or has been dropped.





Do not plug the phonograph in until you verify it is configured for the proper mains voltage.

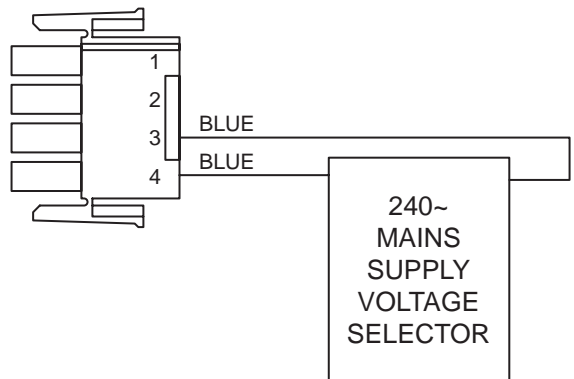
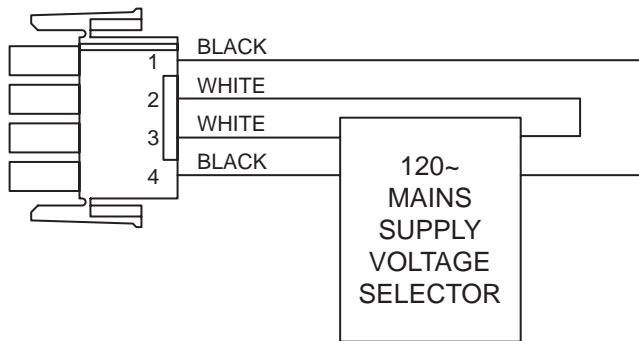
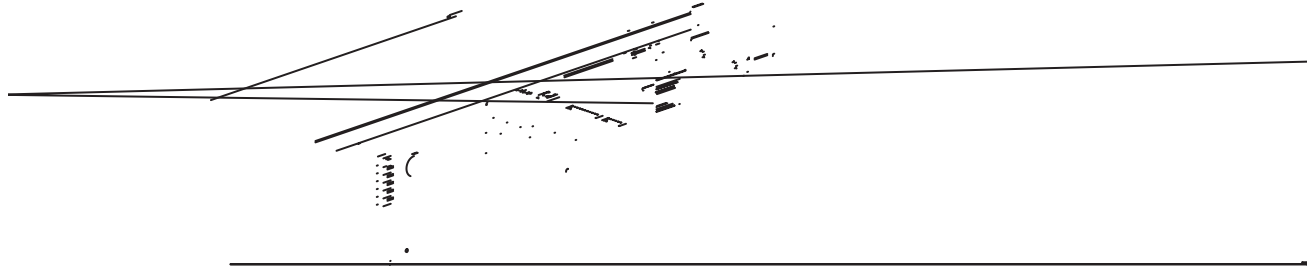

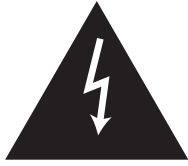

## CAUTION

RISK OF ELECTRIC SHOCK  
DO NOT OPEN



CAUTION: TO REDUCE THE RISK OF ELECTRIC SHOCK, FIRE HAZARD, AND PERSONAL INJURY;

NO OBJECTS FILLED WITH LIQUID, SUCH AS VASES, SHALL BE PLACED ON THE APPARATUS.

DO NOT REMOVE ANY COVERS, GUARDS, OR SHIELDS.

NO USER SERVICEABLE PARTS ARE INSIDE THIS PHONOGRAPH.

REFER SERVICING TO QUALIFIED SERVICE PERSONNEL

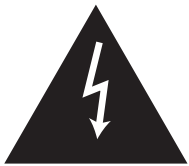

The lightning flash with arrowhead symbol, within an equilateral triangle is intended to alert the user to the presence of uninsulated “dangerous voltage” within the product’s enclosure that may be of sufficient magnitude to constitute a risk of electric shock to persons.



The exclamation point within an equilateral triangle is intended to alert the user to the presence of important operating and maintenance (servicing instructions in the literature accompanying the phonograph).

## Section 1: Installation & System Description

### INTRODUCTION

The CD-100K plays compact discs exclusively. The reliable CD mechanism holds up to 100 compact discs. These discs are played through a 1000 watt stereo amplifier.

Before you begin to unpack and use this phonograph, *please pay special attention to the following:*

#### READ THIS CAREFULLY BEFORE PLACING YOUR NEW PHONOGRAPH INTO SERVICE:

- **Mechanism** - Completely unpack the mechanism before plugging in the AC power line cord.
- **Title Pages** - If you wish to turn the title pages manually, use the Title Page Knob on the back of the title page assembly (see *Figure 1-2*).
- **CD Player** - Read the CD player unpacking procedure and the static caution that accompanies the procedure.

## FEATURES

The major CD-100K features are:

### General Features:

- All lighting done with LED's. No fluorescent or incandescent lamps used.
- LED lighting controllable by IR remote
- Sturdy construction and reliable design
- Conveniently located customer, operator, and service controls
- Message Center Display
- Electrically operated title pages
- Entire albums can be selected
- A 1000-watt (500 per channel) amplifier. Two-channel preamplifier with dual 7-band graphic equalizer.
- AVC keeps CD volume constant
- Volume controlled by IR remote and wired potentiometers
- 100 disc capacity
- As selected (FIFO) playback or random playback
- 500 bill capacity
- Attract mode to merchandise music or advertising with the use of the message center
- Many phonograph programming options
- Total of 50 selections may be "locked out". Total of 100 selections may be "priorities".
- Total of 30 selections may be "premium." Premium can be 2, 3, 4, etc., standard credits.
- Real-time clock allows scheduling of Autoplay, Lockouts, Free Play, and Messages by time and day
- Accessories available to play background music and/or autoplay at different volume levels
- Timed alternate pricing
- "My Song First" feature to play a song ahead of songs previously selected

### Service Features:

- All servicing can be done from the front of the phonograph
- Modular component construction for easy removal and replacement
- Alpha/Numeric display gives you more comprehensive readouts
- Complete cash and play audit information
- Three levels of security access provide limited access to route operators if desired
- Disc condition logging feature to help find skipping selections and unplayable discs
- Machine errors and disc conditions are logged by time and date
- Choice of 3 CD initialization procedures
- RS-232 interface allows you to print audit data, Memorec data, pricing options, disc conditions, and error history

---

## UNPACKING INSTRUCTIONS

This section contains information for unpacking the phonograph and installing it on location. The phonograph is shipped with all major components in place. Save all tie-down hardware in case the CD-100K must be moved to another location.

### Exterior

1. Remove the shipping carton with care: Do not use shipping hooks or sharp tools that could damage the phonograph cabinet.
2. Remove the plastic bag that covers the phonograph.
3. Carefully inspect the interior and exterior of the phonograph to ensure that no damage occurred during transit.

If damage is detected, the carrier who delivered the phonograph should be contacted immediately to examine it. Regardless of the exterior condition of the shipping cartons, the carrier should be called and notified of damage. Do not destroy packing material or boxes until the carrier's agent has examined them. Damage claims are your responsibility. Do not return shipping-damaged merchandise until after your claim has been established. Once your claim has been established, merchandise may be returned to your Rowe distributor for repair. The invoice amount for repair charges can then be collected from the carrier.

### Doors

Locate the red bag in the top hand hold on the back of the cabinet. Remove the door key from the bag and unlock the top door. The lock is on the left side of the top door.

### Shipping Bolts, Clips, and Tape

#### TITLE PAGE ASSEMBLY

See Next Page





**WARNING:**

Do not attempt to turn the CD title pages by hand. Use the handwheel on the back of the title page assembly (see *Figure 1-2*). Title rack will not operate without the two Shipping Screws being removed. Trying to force movement in the Title rack can result in broken parts.

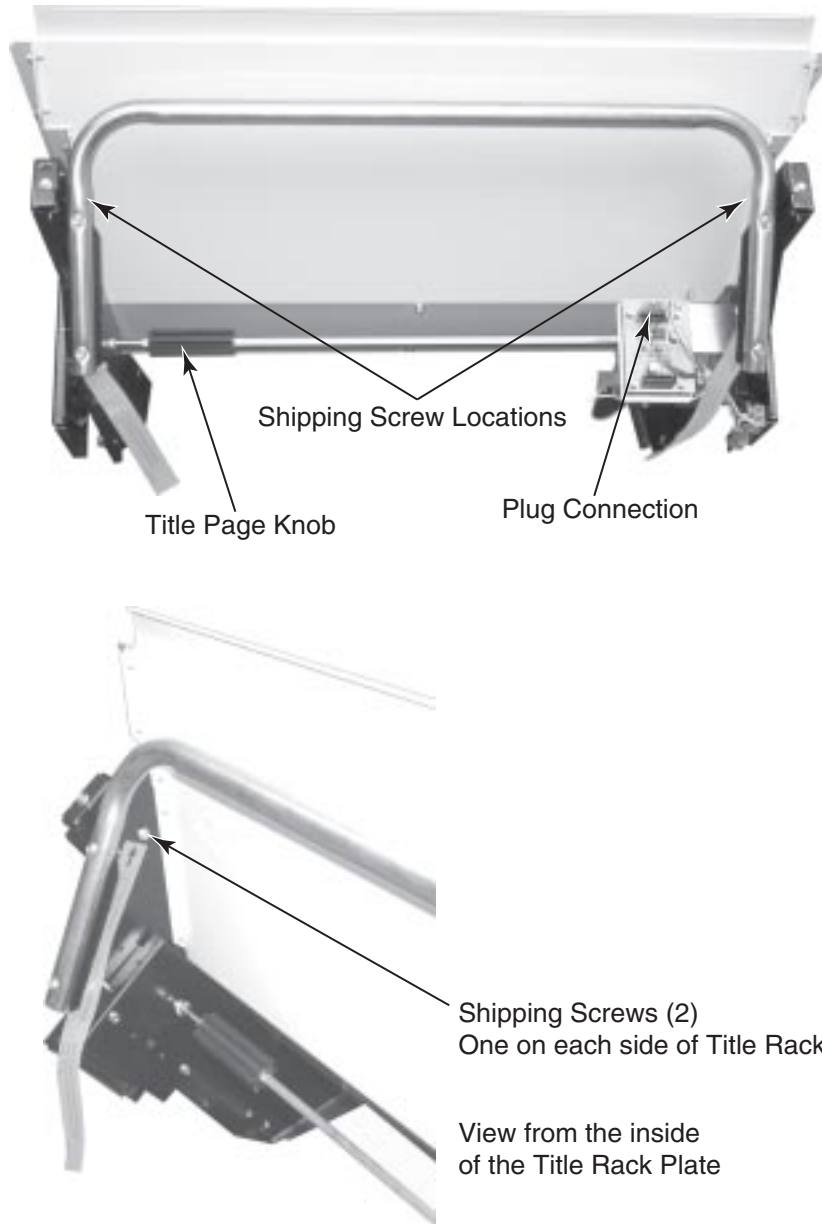

**Title Page Assembly in the “UP” Position**

**Figure 1-2. Title Page**

**Title Page Assembly**

1. Remove the shipping screws from both ends of the lower title page assembly support bracket.
2. Remove the shipping band from the front of the title page assembly.
3. Check to see if the title page assembly is plugged in (see *Figure 1-2 above*).
4. Remove (2) shipping screws from the back of the cabinet (toward the top) to allow title page assembly removal.

Save all shipping hardware that you remove in the following six steps:

## Mechanism

### CDUNPACKING

1. Remove the CD changer mechanism shipping bolt from the back of the phonograph cabinet (see *Figure 1-3*).

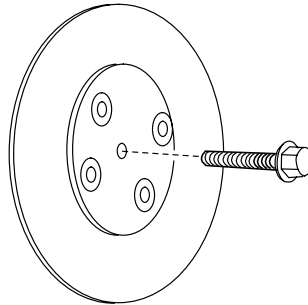

**Figure 1-3. Shipping Bolt Removal**

2. Remove the shipping tape from the front ends of the mechanism tie-down levers on the side of the mechanism frame (see *Figure 1-4*).
3. Push the end of the lever down slightly, rotate the lever away from the frame until the latch tab clears the hole in the frame, rotate the lever up until the mechanism is free, and remove the levers.

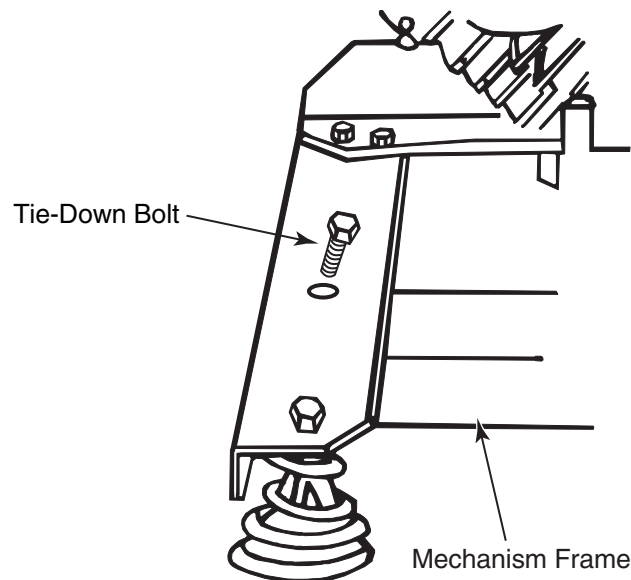

**Figure 1-4. CD Changer Tie-Down Screws**

Do not proceed with unpacking until you read and understand the following caution:



### **CAUTION:**

The CD mechanism is sensitive to static discharges. The photo diodes and the laser are more sensitive to discharges than MOSIC's. Careless handling may immediately destroy components within the player or cause undetectable damage that will lead to failure after several weeks or even months of use. Before you touch the player, discharge your hands and tools by touching a grounded metal part of the phonograph, such as the amplifier or power supply chassis. If you need to remove the CD player for servicing, place the CD player into the anti-static bag (shipped with the phonograph for this purpose) immediately after you remove it from the phonograph.

4. Remove the rubber band on the hold-down plate.
5. Remove the rubber band, wire hook, and warning tag that hold the sprag lever out of the sprag wheel.
6. Remove all tape from the magazine belt and magazine pulley.
7. Check to see that the title page assembly is plugged in.

## **VISUAL INSPECTION**

Check to be sure that all electrical plugs are completely seated into their receptacles.

## **PHONOGRAPH LEVELING**

To insure proper operation, level the phonograph cabinet from left-to-right and front-to-back by inserting spacers under the caster wheels.

## **HANDY CASE**

Locate the Handy Case in a blue plastic envelope. The Handy Case contains a variety of items, including the phonograph service manual and parts catalog, spare parts, and fuses. Keep the Handy Case inside the phonograph so the service manual and parts will be readily available when needed.

## **WARRANTY REGISTRATION CARD**

A postage-paid Warranty Registration Card is included with the phonograph. This card should be filled out and returned to Rowe.

## **MAJOR COMPONENTS OF THE CD-100K**

*Figure 1-1* shows the major components of the CD-100K Phonograph. Take a minute to familiarize yourself with these components.

*Table 8-1 (Volume 2, Section 8)* lists the accessories that you may have in addition to the standard phonograph.

## CD Selection System

CD selections are made by entering the four-digit selection number on the selector keyboard (see Figure 1-5).

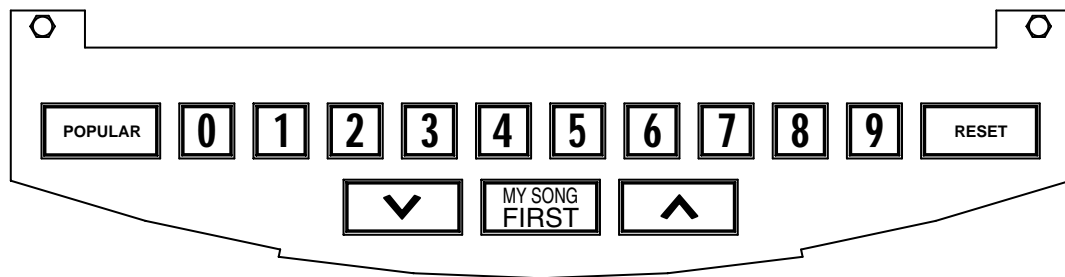

Figure 1-5. Keyboard

### Keyboard

The keyboard consists of 15 keys: Ten digit keys and five special keys. The two PAGE CHANGE keys move the title pages electrically. The RESET button allows the customer to reenter his selection if he has changed his mind or made a mistake. The POPULAR key selects the selection that customers have selected the greatest number of times. Pressing the POPULAR key a second time will select the second most popular selection. Pressing the POPULAR key a third time will select the third most popular selection and so on. The POPULAR key selection feature can be disabled if desired - see *Command 6994* in *Table 2-4*. The “My Song First” key allows a customer to put his song (for extra credit) ahead of other songs that have been selected previously. See *COMMAND 528* to disable this feature. See *COMMAND 529* to set the number of credits to “Make My Song First”.



#### NOTE:

**On a new phonograph, a phonograph that has had its CCC replaced, or a phonograph that has had the POPULARITY cleared, the POPULAR key will not select any disc number until at least one normal selection has been made.**

### Central Control Computer

The central control computer (CCC) keeps track of all of the phonograph’s activities and determines what the various components are to do next. The CCC regulates the following functions:

- Calculating credit and making selections
- Keeping track of selections not yet played
- Calculating the most popular selection list
- Remembering the operator’s programmed values
- Storing and displaying the message center information

### Memorec

Memorec is the part of the CCC that remembers the:

- Number of times each selection was played
- The total amount of money deposited in the phonograph

## Autoplay

When no selections have been made for a predetermined time, the Autoplay feature will play selections from a programmed list or make random selections. The choice of which selections are chosen, the selection sequence, and the selection interval can be programmed by the owner or service person.

## PRINCIPLES OF OPERATION

### Audio System

The audio system consists of the electronic components that transform the recorded sound into music. The major components of the audio system are the:

- CD Player
- Stereo Preamplifier and Stereo Amplifier
- Output Transformers
- Speaker System

### CD PLAYER

This subassembly translates digital pulses from the CD into a left and right channel audio signal.

### STEREO PREAMP (Figure 1-6)

The preamp increases the signal from the CD player, corrects for varying recording levels (automatic volume control or AVC), allows the volume to be adjusted manually, and modifies the CD tone (tone changes are made through a 7-band graphic equalizer).

### STEREO AMPLIFIER (Figure 1-6)

The power amplifier converts the preamp signal to a signal that can be used by the phonograph speakers.

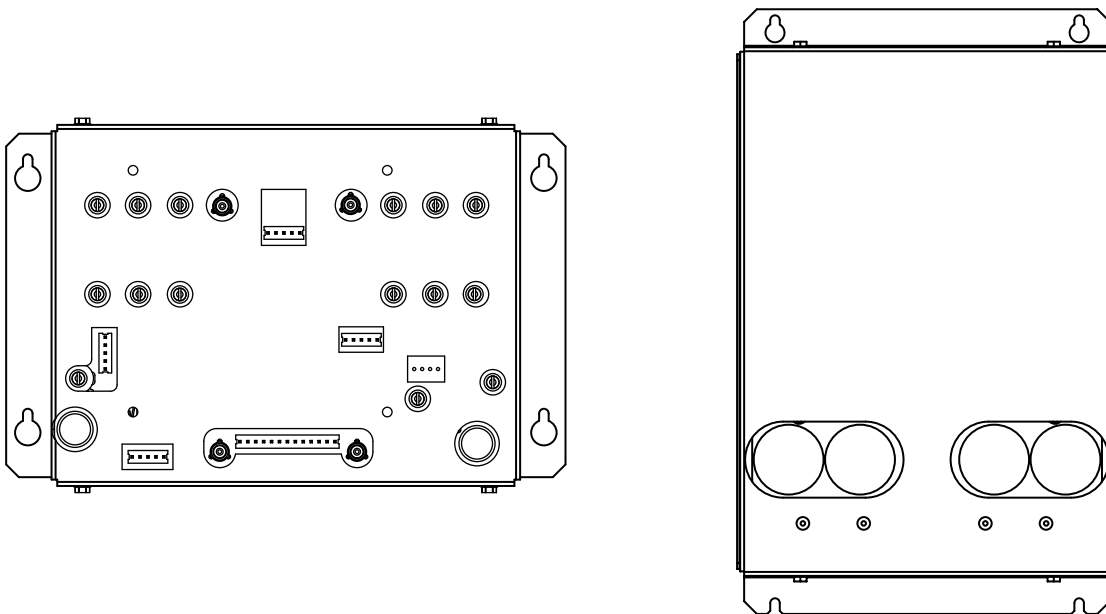

Figure 1-6. 1000 Watt Stereo Amplifier Components

### Two-Wire Volume Control

A Rowe innovation, the two-wire volume control simplifies complex installations and reduces cost. A special preamplifier design permits volume control wiring using any unshielded two-wire cable.

### OUTPUT TRANSFORMERS

The output transformers (*Figure 1-7*) “step up” the power amplifier’s output voltage for 70-volt extension speakers. The output transformers also provide connections (taps) for selecting different power levels for the speakers.

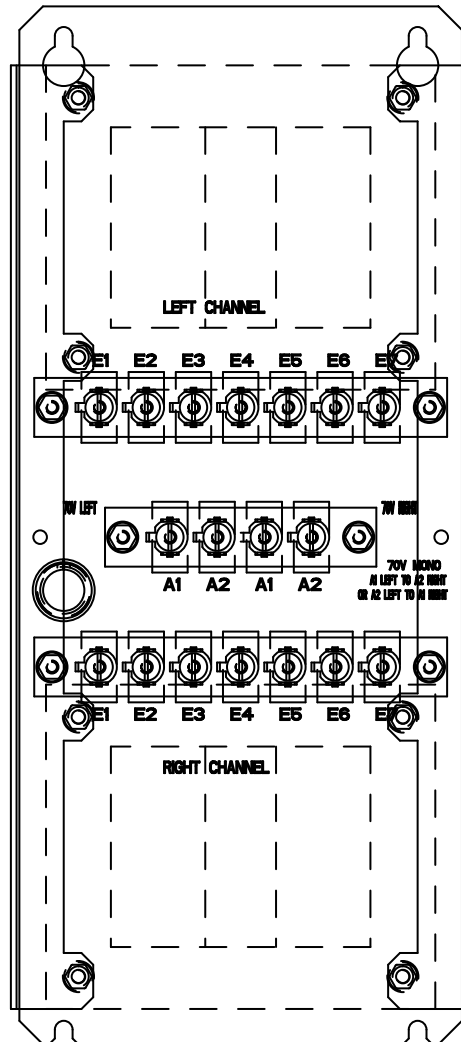

Figure 1-7. Output Transformer Package Components

### SPEAKER SYSTEM

The speaker system consists of two specially designed speaker channels. Each channel consists of one woofer, one mid/high range speaker, a tweeter, and a crossover network.

## CD Changer Mechanism

The CD changer mechanism, also referred to as the “mechanism” or “mech”, is located in the center of the cabinet’s interior. It is the primary mechanical component of the phonograph. The mechanism holds 100 CD’s and plays selections on command from the selection system. (Refer to Figure 1-8 for the location of each of the major mechanism components.)

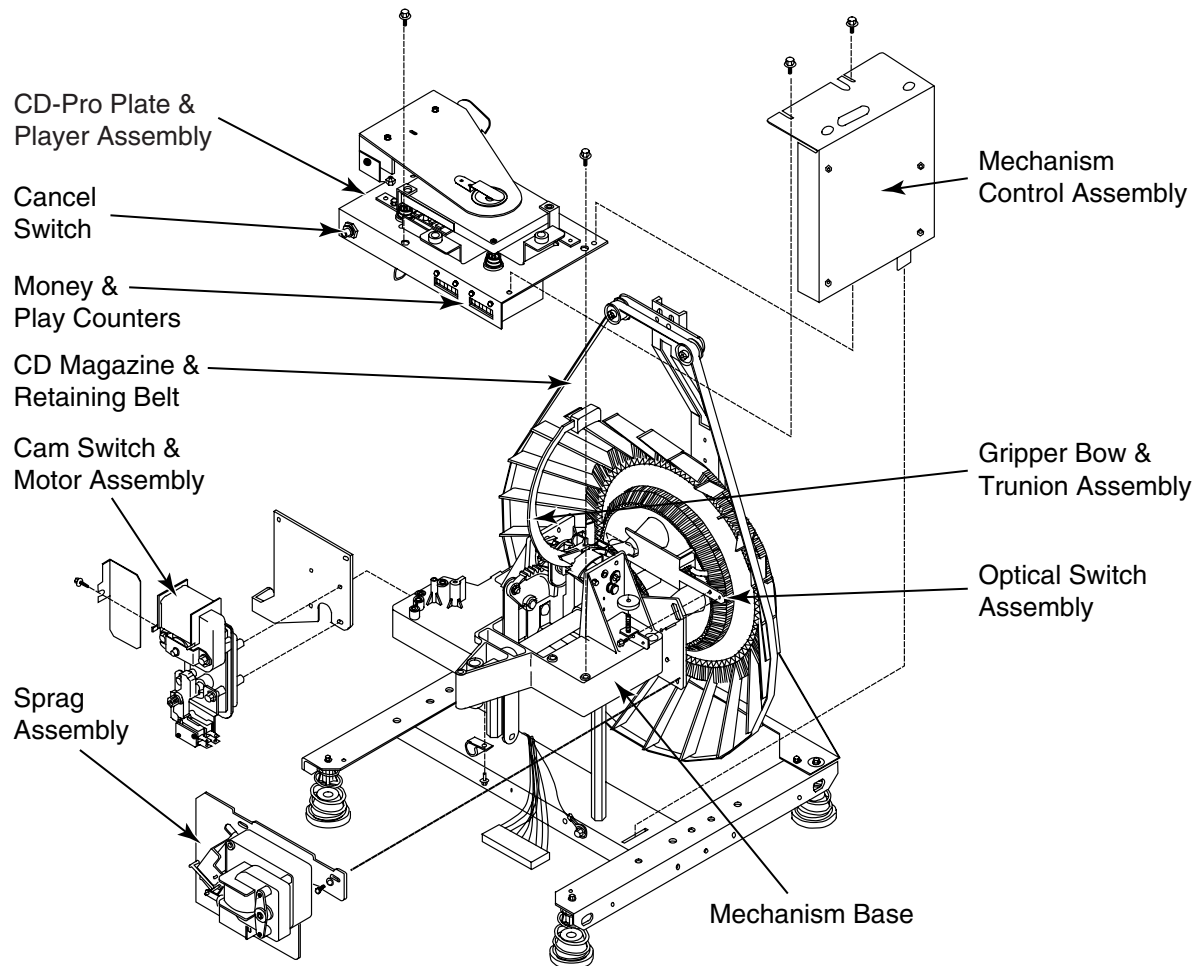

Figure 1-8. CD Changer Mechanism

### MAGAZINE

The CD magazine stores 100 CD’s.

### PLAYCOUNTER

The play counter accumulates the total number of plays on the mechanism.

### MONEY COUNTER

The money counter registers the total money deposited in the phonograph.

### OPTICAL SWITCH

The optical switch senses the CD magazine position so that the CCC can determine which CD is in gripping position.

**CAM SWITCH AND MOTOR ASSEMBLY**

The cam switch and motor assembly (see Figure 1-9) consists of the transfer motor, cam, and two cam switches.

**SPRAG ASSEMBLY**

This assembly locks the CD magazine in position.

**CD MODULES**

The CD player plays the CD's after they are positioned on the turntable by the disk transfer arm.

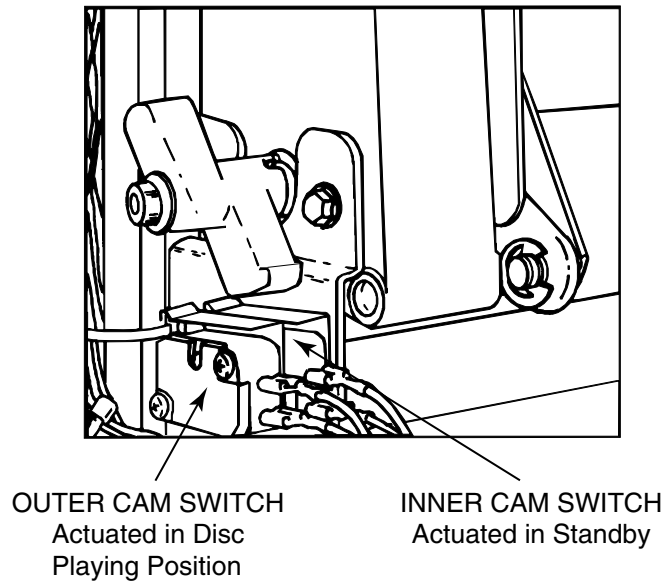

**Figure 1-9. Cam Switch & Motor Assembly**



## Mechanism Control Unit

This solid-state switching unit controls the scan and transfer.

## Main Power Supply

The main power supply (*Figure 1-10*) distributes unregulated +24 VDC, +12 VDC, and regulated +9 VDC to the phonograph. The mains voltage (120 VAC or 240 VAC) to the main power supply is controlled by the power switch on the back of the phonograph cabinet. The phonograph is factory configured for 120 ~ main voltage. For 220 to 240 voltage, remove the 120 ~ Mains Supply Voltage Selector plug from the power supply, and install the 240 ~ Mains Supply Voltage Selector plug. Note - the Central Control Computer is attached to the front of the Main Power Supply.

## Lighting and Bill Acceptor Power Control

When the CANCEL button is held down for 5 seconds, a relay opens removing power from the LED lighting and the Bill Acceptor. Push the CANCEL button to apply power. Pushing the POWER button on the IR Remote will also operate the above relay.

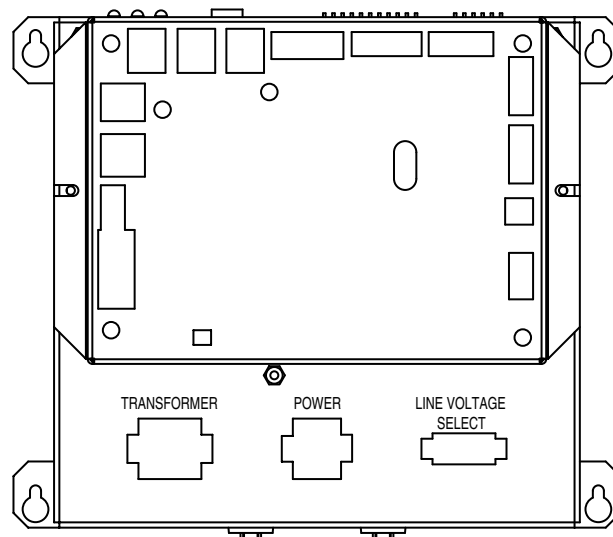

Figure 1-10. Main Power Supply.

## Section 2: Installation & Programming

### INTRODUCTION

This section describes the installation and programming process. This information begins with a summary of what happens when the phonograph is powered up and continues with detailed instructions on how to load the titles and discs, modify the pricing, and set up the sound system. The last part of this section describes how to make other programming changes. (You can keep a record of the factory settings and your changes by using the *Operator's Setup Sheet* at the end of this section if you wish.)

### POWER ON



Do not plug the phonograph in until you verify it is configured for the proper mains voltage.

The phonograph is factory configured for 120 AC (~) mains voltage.

For 220 to 240 mains voltage, remove the 120 ~ Mains Supply Voltage Selector plug from the 61145001 Main Power Supply, and install the 240 ~ Main Supply Voltage Selector plug.

The 240 ~ Mains Supply Voltage Selector plug is factory shipped in the coin cash bag.

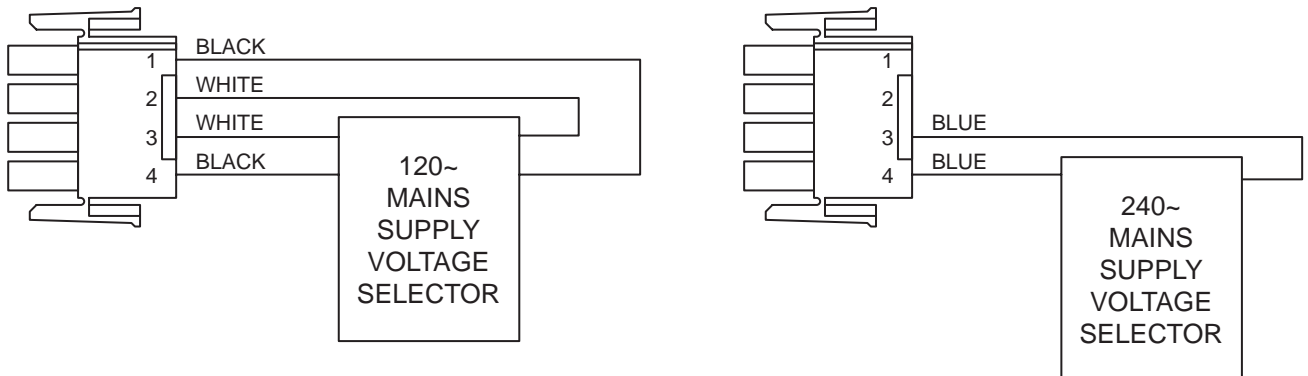

The following steps are a summary of the detailed *Power On Process* that is described in *Section 5* of *Volume 2*.

- Step 1. Power switch on rear of phonograph is turned on, main power supply +9 VDC, +12 VDC, and +24 VDC LED's light, and all modules and components receive power. The 120~ relay closes, supplying 120~ to the LED control and bill acceptor.
- Step 2. The Voltage LED's light on the CCC, mechanism control, KID controller, IR volume control, and title display CBA. The Board Error LED's on the CCC and mechanism control flash three times. The CCC Rowelink Command, mechanism control and KID controller Rowelink TX, and IR volume control Rowelink RCV LED's continuously flicker.
- Step 3. Phonograph is ready to operate.



**CAUTION:**

Do not attempt to turn the CD title pages by hand. If the title page assembly is unplugged or not operating electronically, use the handwheel on the back of the assembly (see *Figure 1-2*).

## LOADING CD'S AND TITLES

The procedure for loading CD's and titles into an empty phonograph is different from the procedure to change CD's and titles. Please make sure you are following the procedure that describes your situation.

### Preparing Titles for the Title Holder

If your titles have not been shipped with the discs or preprinted, you will need to prepare the title strips yourself.

## Loading the Title Holder

All of the titles on the title strip sheet can be used for either right- or left-hand titles. If your title strips have not been preprinted, you may want to type the titles before you tear the individual title strips off the title strip sheet.

Refer to the sample in *Figure 2-1* for an illustration of where to tear the title strips off the title strip sheets.

These procedures describe how to load one CD album and one title strip. Repeat this procedure for each CD that is being loaded.

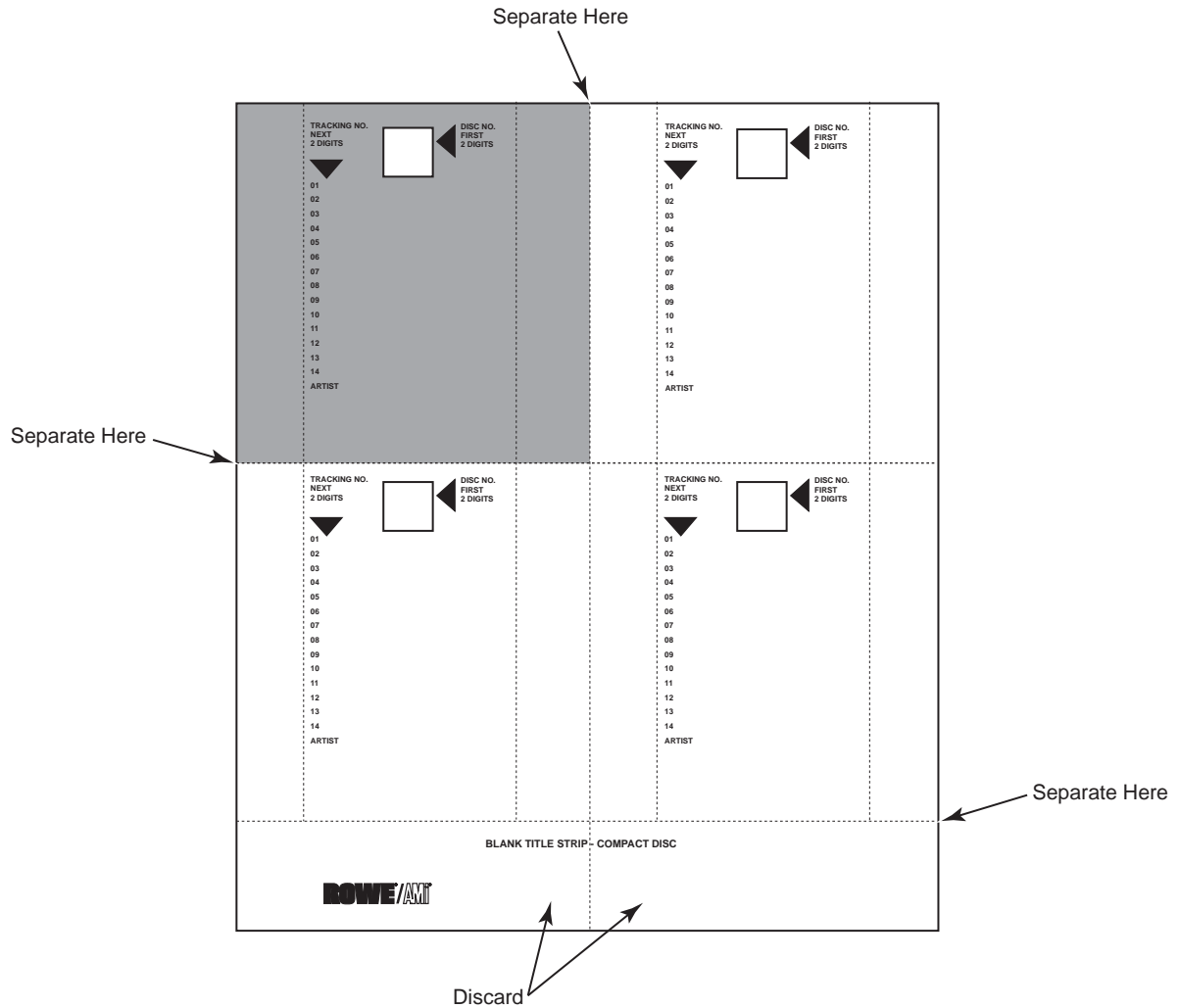

**Figure 2-1. Blank Title Sheet**

## PROCEDURES FOR LOADING THE TITLE PAGE HOLDER

1. Tear each title strip from the title sheet so the perforated column appears on the side of the title strip. (The shaded portion of the title strip in *Figure 2-1* represents a title strip that has been removed from the title sheet).
2. Fold the title strip along the perforated line on both sides of the title strip (*see Figure 2-2*).
3. Locate the CD album booklet that matches the title strip you have just made. If the CD booklet is more than two sheets thick, remove the inner sheets so that the booklet is no thicker than two title strips.

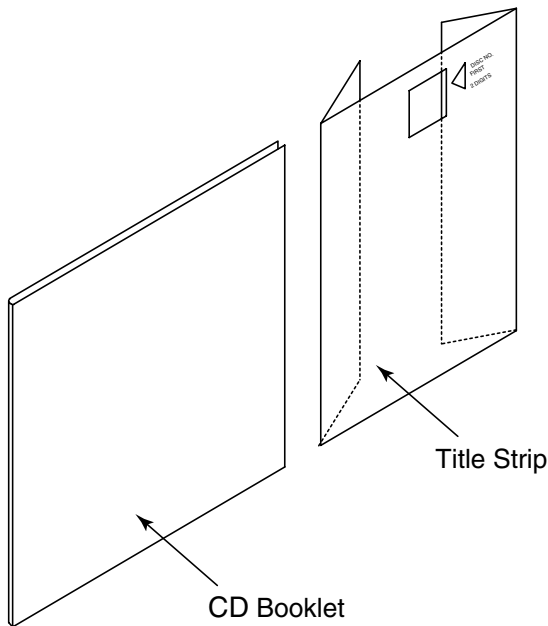

**Figure 2-2. Folding the Title Strip**

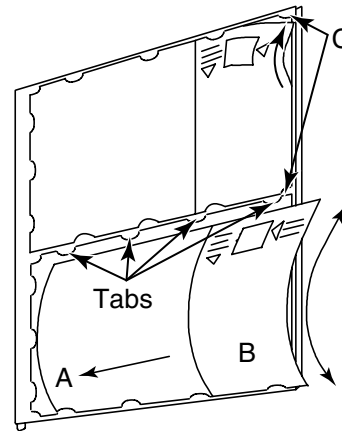

**Figure 2-3. Loading the Title Page Holder  
(2 of 6 Pages Shown)**

4. Insert the CD booklet under the top and bottom tabs of the title page. Slide the CD booklet over until it is trapped by the molded stops on the title page holder (*see Figure 2-3, Ref. A*).
5. Insert the folded title strip under the top and bottom tabs of the title holder. Slide the title strip until the disc number shows in the opening of the title strip and the title strip is locked in place by the molded stops (*see Figure 2-3, Ref. B*).
6. All of the tabs surrounding the CD booklet and title strip should be holding them in place. If you missed a tab, carefully tuck the loose paper under the tab as shown in *Figure 2-3, Ref. C*.
7. Repeat Steps 4 and 5 until all titles are installed. Use the page keys switch (*Figure 1-5*) to change title pages. Insert filler title strips to fill out any unused space left on a page. Insert these in the same way that you installed the fill-in title strips.

## PROCEDURES FOR LOADING DISCS

Load discs as follows:

1. Unlock and open the top door.
2. Pull the SERVICE button out to the SERVICE position (*refer to Figure 2-4*). The SERVICE switch is located in the upper right-hand corner of the cabinet.
3. Press the CANCEL/SCAN button (located on the CD changer mechanism) to move the disc space to the left or right of the transfer arm.
4. Slide the CD into the slot with the label to the right.

Note that disc positions in the molded CD magazine are identified by numbers at every other slot, with even numbered slots labeled on one half of the magazine and odd numbered slots labeled on the other half.

For example, on the even numbered half of the magazine, slots 00, 04, and 08 are labeled, and the slots in between – 02 and 06 – are not, as illustrated in *Figure 2-5*.

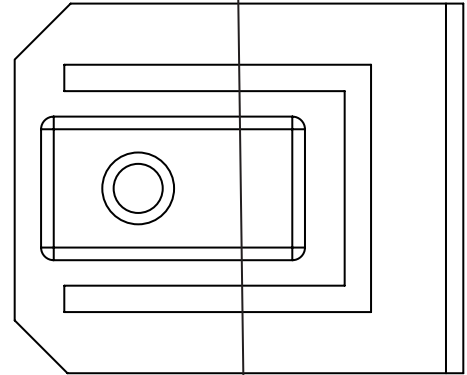
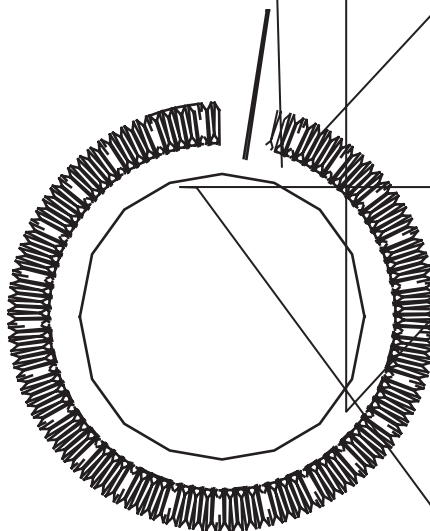

**Figure 2-4. Service Switch**



### NOTE:

When loading the magazine, make sure the disc rests in the same numbered slot in both the front and rear of the magazine.



**Figure 2-5. Loading the Molded CD Magazine**

**NOTE:**

When loading discs, be sure to keep the magazine disc load approximately balanced. If the magazine is partially loaded with all discs on one side, the sprag wheel may lock and the magazine will not turn.

5. Check title strips and disc sequence to ensure that the titles and discs correspond.
6. After all titles and discs are in the proper places, perform a disc initialization. Initialization is performed in the following manner:

**NOTE:**

You may wish to release the two catches that hold the display in place and lower the keyboard/display.

- A. Make sure that the phonograph is in the SERVICE mode and \*SERVICE MODE\* or \_\_ \_ ERRORS EXIST \_\_ \_ appears on the display.
- B. Type 3 to select the INITIALIZE submenu and type 0. FULL INITIALIZE will appear on the display. Press POPULAR to start the initialization and close the top door or place the phonograph in NORMAL mode.

The initialization process will start and continue for approximately 30 minutes. During this time, the phonograph can be used (*see the notes that follow*).

7. When initialization is finished, check that all discs have initialized. To do this, reenter the SERVICE mode and:
  - A. Type 3 to select the INITIALIZE submenu, and then type 4 to view the number of discs that have been initialized. If this number does not match the number of discs that should have been initialized, do the following step. If the number matches the number of discs that you expected to be initialized, initialization is complete.
  - B. If the number of discs initialized does not match the number of discs that you expected to be initialized, hold RESET and press 0 twice. This will place you in the DISC \_\_ TRACK \_\_ menu and display the first disc and its number of selections. Hold RESET and press 3 to see the next disc and its number of selections. Continue through the list by holding RESET and pressing 3 until you find a disc with the number of tracks equal to 0 (zero). Continue through the disc list noting all discs with track numbers equal to 0.
  - C. Check that each disc on your list (ones with track numbers equal to 0) is in the proper slot, with the label facing to the right. If it is not, move it to the proper slot. If the disc is in the proper slot, it may be defective. Repair or replace it and do the individual disc initialization (*see Changing Discs in Section 3*).

**NOTE:**

1. The initialization process will stop whenever the phonograph is in the SERVICE mode, and will resume when the phonograph is returned to the NORMAL mode if the phonograph is in Standby (i.e., no selections are in memory).
2. During full initialization, all disc limits are initially set to 99. As each disc is scanned, the proper limits for that disc are stored in memory allowing only valid selections to be made.

**SETTING TITLE PAGE LIMITS FOR THE FIRST TIME**

This procedure gives you specific instructions on how to set the page limits only.

The phonograph is shipped with all pages accessible. Pages 1 through 9 can be “flipped” and viewed. When you install discs, you may not need all 9 pages. If you do not need all 9 pages, you should restrict page movement to just those pages that have titles. Set the title page limits as follows:

1. Unlock and open the top door.
2. Pull the SERVICE button out to the SERVICE position (*refer to Figure 2-4*).
3. Make sure that \*SERVICE MODE\* or \_\_ ERRORS EXIST \_\_ appears on the display.
4. Type 2 to select the ATTRACT submenu then type 4 to select the PAGELIMIT function and you will see the display for entering the first page number to use and the last number to use. Press POPULAR, which sets the first page number to 1. Notice that the blinking number has moved to the right. Type the last page number to be used and press POPULAR. Flip the keyboard display back up, making sure that both catches are engaged.

**PRICING**

The prices charged for CD selections may be changed as needed. When shipped from the factory, the prices are set as follows:



Figure 2-6A. Price Card

**NOTE:**

If you are using the factory pricing, skip to *Sound System Set Up*.



**To Set Disc Prices:**

The Handy Case has a Price Card (see Figure 2-6A) that may be substituted for the Standard Price Card. The Handy Case also contains a Price Sheet with printed prices (see Figure 2-6B) which can be peeled off and placed at the appropriate location on the Price Card.

Using the phonograph keyboard, the pricing structure of the phonograph may be adjusted to match the prices on the Price Card. The maximum amount that can be charged for a selection is \$99.95. The maximum number of selections that can be entered is 999. The POPULAR key must be pressed to record the data entered on the display.

|        |        |        |        |        |        |        |        |        |        |        |        |        |        |        |        |        |        |        |        |        |        |        |        |    |
|--------|--------|--------|--------|--------|--------|--------|--------|--------|--------|--------|--------|--------|--------|--------|--------|--------|--------|--------|--------|--------|--------|--------|--------|----|
| 1      | 1      | 1      | 1      | 1      | 1      | 1      | 1      | 1      | 1      | 2      | 2      | 2      | 2      | 2      | 2      | 2      | 2      | 2      | 3      | 3      | 3      | 3      | 3      | 3  |
| 3      | 3      | 4      | 4      | 4      | 4      | 4      | 4      | 4      | 4      | 4      | 5      | 5      | 5      | 5      | 5      | 5      | 5      | 5      | 6      | 6      | 6      | 6      | 6      | 7  |
| 7      | 7      | 7      | 7      | 8      | 8      | 8      | 8      | 8      | 8      | 9      | 9      | 9      | 9      | 9      | 10     | 10     | 10     | 10     | 10     | 11     | 11     | 11     | 11     | 12 |
| 12     | 12     | 12     | 13     | 13     | 13     | 13     | 13     | 14     | 14     | 14     | 14     | 14     | 14     | 15     | 15     | 15     | 15     | 15     | 16     | 16     | 16     | 16     | 18     |    |
| 19     | 19     | 19     | 19     | 19     | 20     | 20     | 20     | 20     | 20     | 21     | 21     | 21     | 25     | 25     | 25     | 25     | 30     | 30     | 30     | 35     | 40     | 40     | 45     |    |
| 55     | 60     | 60     |        |        |        |        |        |        |        |        |        |        |        |        |        |        |        |        |        |        |        |        |        |    |
| 20P    | 20P    | 20P    | 20P    | 20P    | 20P    | 20P    | 30P    | 30P    | 30P    | 30P    | 30P    | 30P    | 30P    | 30P    | 30P    | 30P    | 40P    | 40P    | 40P    | 40P    | 40P    | 40P    | 40P    |    |
| 50P    | 50P    | 50P    | 50P    | 50P    | 50P    | 50P    | 50P    | 50P    | 50P    | 10c    | 10c    | 10c    | 20c    | 20c    | 20c    | 20c    | 25c    | 25c    | 25c    | 25c    | 25c    | 25c    | 40c    |    |
| 40c    | 40c    | 50c    | 50c    | 50c    | 60c    | 60c    | 60c    | 60c    | 80c    | 80c    | 80c    | 80c    | 1.00   | 1.00   | 1.00   | 1.00   | 1.00   | 1.00   | 1.00   | 1.00   | 1.00   | 1.00   | 2.00   |    |
| \$2.00 | \$2.00 | \$2.00 | \$3.00 | \$3.00 | \$3.00 | \$3.00 | \$3.00 | \$4.00 | \$4.00 | \$4.00 | \$4.00 | \$4.00 | \$5.00 | \$5.00 | \$5.00 | \$5.00 | \$5.00 | \$5.00 | \$5.00 | \$5.00 | \$5.00 | \$5.00 | \$1.00 |    |
| \$1.00 | \$1.00 | \$1.00 | \$1.00 | \$1.00 | \$1.50 | \$1.50 | \$1.50 | \$1.50 | \$1.50 | \$1.50 | \$1.50 | \$2.00 | \$2.00 | \$2.00 | \$2.00 | \$2.00 | \$2.00 | \$2.00 | \$2.00 | \$2.00 | \$2.00 | \$2.00 | \$1.00 |    |
| A1.00  | A1.00  | A1.00  | A1.50  | A1.50  | A1.50  | A2.00  | A2.00  | A2.00  | A2.00  | A2.00  | A2.00  | A2.00  | A2.00  | A2.00  | A2.00  | A2.00  | A3.00  | A3.00  | A3.00  | A3.00  | A3.00  | A3.00  | A4.00  |    |
| A4.00  | A4.00  | A4.00  | A5.00  | A5.00  | A5.00  | A5.00  | A5.00  | A5.00  | A5.00  | A5.00  | A5.00  | A5.00  | A10.00 | A10.00 | A10.00 | A10.00 | 1KR    | 1KR    | 1KR    | 1KR    | 1KR    | 1KR    | 5KR    |    |
| 5KR    |        |        |        |        |        |        |        |        |        |        |        |        |        |        |        |        |        |        |        |        |        |        |        |    |

**ENGLISH:**  
INSTRUCTIONS:  
IF SPECIAL PRICING IS REQUIRED, USE THE UNIVERSAL PRICE SELECTION SHEET AND THE EXTRA PRICE CARD IN THE HANDYCASE.  
1. PEEL DESIRED PRICING STRIP FROM THE SHEET AND CAREFULLY LOCATE IT OVER THE APPROPRIATE COLOR BAND NUMBER OF SELECTIONS ON THE LEFT, PRICE OF SELECTION ON THE RIGHT.  
2. IF A PARTICULAR PRICING IS NOT WANTED, PEEL OFF BLACK STRIP AND CAREFULLY PLACE OVER PRICING AND SELECTION NOT WANTED.

**FRENCH:**  
INSTRUCTIONS:  
POUR PRIX SPECIAUX VEUILLEZ UTILISER LA FEUILLE UNIVERSELLE DES PRIX DE SELECTION ET LA CARTE DE PRIX SUPPLEMENTAIRE DANS LA POCHETTE.  
1. DECOLLEZ DE LA FEUILLE L'ETIQUETTE DE PRIX ET PLACEZ LA SOIGNEUSEMENT SUR LA BANDE DE COULEUR APPROPRIEE (NOMBRE DE SELECTIONS A GAUCHE, PRIX DES SELECTIONS A DROITE).  
2. SI UN PRIX PARTICULIER N'EST PAS DEMANDE, DECOLLEZ LES ETIQUETTES NEUTRES ET PLACEZ LES SOIGNEUSEMENT SUR LES PRIX ET SELECTIONS NON DESIRES.

**GERMAN:**  
INSTRUCTIONS:  
FUER SPEZIALPREISE BITTE DAS ALLGEMEINE PREISWAHLSATT UND DIE EXTRA-PREISKARTE IN DER MAPPE BENUTZEN.  
1. GEWUNSCHTER PREISSTREIFEN ABZIEHEN UND VORSICHTIG UEBER DEN ZUGEHOEHRIGEN FARBSTREIFEN PLATZIEREN (ANZAHL WAHL LINKS, PREIS WAHL RECHTS).  
2. WENN KEINE BESONDERE PREISE VERLANGT WERDEN, NEUTRALE STREIFEN ABZIEHEN UND VORSICHTIG AUF DIE PREIS UND WAHLAGENDEN PLATZIEREN, DIE NICHT ERWUNSCHT SIND.

61031403

**Figure 2-6B. Universal Price Sheet**

To set the pricing, follow the steps to complete the Price Card and enter the prices. Also, for your records, fill in the Pricing section of the Rowe CD Phono Operator's Set Up Sheet at the end of this section. Before making the actual pricing changes, go through the sample pricing that follows.

**How CD-100K Pricing Works**

Pricing is determined by the numbers that are stored in the PRICE LEVELS and PLAYS @ LEVEL menus. The LEVEL 1 PRICE corresponds to the LEVEL 1 PLAYS in the following way: Enough money must be deposited to reach the first (#1) price level before any selections can be made. Once the amount of money matches this price, the number of selections in the LEVEL 1 PLAYS menu can be made.

To make pricing changes, set the LEVEL 1 PRICE and LEVEL 1 PLAYS to match the lowest price and number of plays on the Price Card. Then enter the remaining PRICE LEVELS and PLAYS @ LEVEL until you have set all five levels. (If you do not have prices for all levels, enter 0's in all of the remaining PRICE and PLAYS positions.)

**SAMPLE PRICE CHANGES**

1. Determine the prices that are to be charged for disc selections and place the price decals from the Price Sheet into the slots on the Price Card. The following is an example of a completed Price Card:

**Price of Selections**

**4 for \$1.00**  
**9 for \$2.00**  
**25 for \$5.00**

2. Enter the SERVICE mode by pulling the SERVICE button to the SERVICE position.

**NOTE:**

This example will not give the correct dollar amounts for U.S. money unless PRICING OPTION 3 is set to 5. (This is the factory setting for U.S. phonographs and you should not have to change it.)

Use the prices in the example that follows to help yourself better understand the phonograph's pricing.

**Example CD Prices**

**4 for \$1.00**

**9 for \$2.00**

**25 for \$5.00**

**If You Have a Problem in a Menu:**

1. Press and hold down RESET and then press 0 until you come to the top of the current menu.
2. If this menu name doesn't help, press and hold RESET and then press POPULAR. This will move you to the top of the previous menu. In most cases, this will return you to the main menu (\*SERVICE MODE\*).
3. If you still cannot determine where you are, press and hold RESET and then press POPULAR again. This will return you to the main menu (\*SERVICE MODE\*).

3. Select the PRICELEVELS menu, Option 1, from the main menu by pressing 511.
4. Now enter the LEVEL 1 PRICE, which is the lowest disc selection price (enter 0100 and press POPULAR).
5. Move down to the next price (LEVEL 2 PRICE) by pressing and holding RESET and then pressing 1. Enter the next highest price (enter 0200 and press POPULAR).
6. Move down to the next price (LEVEL 3 PRICE) by pressing and holding RESET and then pressing 1. Enter the next highest price (enter 0500 and press POPULAR).
7. Move down to the next price (LEVEL 4 PRICE) by pressing and holding RESET and then pressing 1. Enter 0000 (because only three prices are being used) and press POPULAR.
8. Move down to the last price (LEVEL 5 PRICE) by pressing and holding RESET and then pressing 1. Enter 0000 and press POPULAR.
9. Press and hold RESET while pressing POPULAR 2 times. This will place you in the price menu. Select the PLAYS @ LEVEL menu, Option 1, from the main menu by pressing 21.
10. Enter the number of disc selections to be given for the lowest amount on the disc portion of the example price card into LEVEL 1 PLAYS (enter 004 and press POPULAR).

11. Move down to the next play option (LEVEL 2 PLAYS) by pressing and holding RESET and then pressing 1 (enter 009 and press POPULAR).
12. Move down to the next play option (LEVEL 3 PLAYS) by pressing and holding RESET and then pressing 1 (enter 025 and press POPULAR).
13. Move down to the next play option (LEVEL 4 PLAYS) by pressing and holding RESET and then pressing 1 (enter 000 and press POPULAR).
14. Move down to the next play option (LEVEL 5 PLAYS) by pressing and holding RESET and then pressing 1 (enter 000 and press POPULAR).

## CHECKING THE PRICING

Add bills (and coins, if a coin acceptor is installed) to reach the first (or next) price level. Check for proper credit at each price level.

## SOUND SYSTEM SETUP

If you are not using extension speakers, skip to Section 9 and setup the AUDIO EQUALIZERS.

### Extension Speaker Operation

To avoid a poor sounding jukebox, care must be taken when adding extension speakers. Two requirements must be met:

1. Speakers must be wired so that the power consumed by the jukebox speakers and extension speakers does not exceed the amplifier power rating. After wiring the speakers, perform an Amplifier Overload Check.
2. All speakers must be connected with the correct polarity.



### NOTE:

Channel 1 output phase is reversed with respect to channel 2. This reversal is necessary to extend monaural sound in a stereo jukebox system. Because of this reversal, speaker connections to channel 1 must be reversed when compared to channel 2, except for 70 V speaker connections. The 70 V phasing is reversed inside the output transformers. See figure 3-7 for correct polarity hookup of extension speakers. If the (+) and (-) terminals are not wired properly, the speakers will be out of phase, causing a reduction in low frequencies (bass).

Several charts have been included to assist you with connection of the extension speakers.

Figure 3-7 shows the entire sound system.

## 70-Volt Speakers

To avoid prohibitive cable losses on long speaker lines (over 100 feet), use 70 V speakers. The power level in the 70 V speakers is set at each speaker. 250 watts of the 1000 watts is provided for 70 V speakers by A1, A2 connections on the audio output transformer assembly.

**NOTE:** 1000 watts can be connected if you configure the amplifier for stereo and connect 70-volt speakers E7 to E7.

## Low Impedance Speakers

Low impedance speakers (8- or 4-ohm) can be used when the connecting cable is less than 100 feet.

### 4-OHM SPEAKERS

No more than one 4-ohm speaker should be connected to a speaker line. If several 4-ohm speakers are to be used, each speaker should have its own line.

### 8-OHM SPEAKERS

The loss in 100 feet of 18 gauge zipcord feeding one 8-ohm speaker is 15%. The loss for two 8-ohm speakers is 30%.



### **NOTE:**

In any speaker installation, the total speaker load (the sum of all power to all speakers) must not exceed 1000 watts per amplifier. The phonograph has an audio output transformer assembly rated 250 watts (125 per channel) for connecting 70 V speakers, tapping down the phonograph speakers, or connecting extension speakers to taps. The sum of all power to 70 V speakers and tapped speakers must not exceed 250 watts.

**Table 2-1 Extension Speaker Worksheet**

*Sheet 1*

**SELECTING SPEAKER POWER**

**General Instructions**

This section will lead you through the power and speaker selection process. This process consists of four major steps and several smaller steps. The major steps are:

1. Identifying the extension speakers and computing the extension speaker power.
2. Making the external speaker connections.
3. Determining and selecting the jukebox power (Jukebox speakers are 16 ohm).
4. Performing an amplifier overload check per table 3-2B.

**Selection Procedures**

1. Use a pencil (you may want to revise your figures) to fill in the work sheet on the following pages:

Extension speakers are available in these general categories: General purpose speakers (4 and 8 ohm speakers) and 70 V speakers.

Use this worksheet to help you calculate the amount of power consumed by the extension speakers.

Use this worksheet as a guide to help you select which power tap to use for each type of external speaker you are using. An extension speaker RMS power rating should be at least 10% higher than the power it will consume at max phonograph volume.

| <u>When RMS power to speaker<br/>at max phonograph volume is</u> | <u>Then recommended RMS power<br/>rating of speaker is</u> |
|--|--|
| 250 watts  | 300 watts  |
| 125 watts  | 150 watts  |
| 62.5 watts   | 75 watts   |
| 31.25 watts  | 40 watts   |

**Extension speakers connected to E1 - E7**

Place the quantity of speakers in the blank under QTY and multiply the quantity times the power consumption (show stereo speakers as 2 speakers). Place your results in the blank under TOTAL.

|  | <b>QTY</b> |                            | <b>Total</b> |
|--|------------|----------------------------|--------------|
| Two 8 ohm speakers in series:<br>(31.25 watts to each speaker) | _____      | at 62.5 watts per series = | _____ watts  |
| Two 4 ohm speakers in series:<br>(62.5 watts to each speaker)  | _____      | at 125 watts per series =  | _____ watts  |
| 8 ohm speakers:  | _____      | at 125 watts each =        | _____ watts  |
| 4 ohm speakers:  | _____      | at 250 watts each =        | _____ watts  |

## Table 2-1. Extension Speaker Worksheet

### Sheet 2

#### 4-OHM SPEAKERS CONNECTED TO TRANSFORMER TAPS

Place the quantity of speakers in the blank under QTY and multiply the quantity times the power consumption (show stereo speakers as 2 speakers). Place your results in the blank under TOTAL.

#### 4-Ohm Stereo Speakers connected to transformer taps

|                                 | QTY                       | Total       | Connections |
|---------------------------------|---------------------------|-------------|-------------|
| Speakers for the 1 watt taps:   | _____ at 1 watt each =    | _____ watts | (E1 to E2)  |
| Speakers for the 4 watt taps:   | _____ at 4 watts each =   | _____ watts | (E1 to E3)  |
| Speakers for the 16 watt taps:  | _____ at 16 watts each =  | _____ watts | (E1 to E4)  |
| Speakers for the 36 watt taps:  | _____ at 36 watts each =  | _____ watts | (E3 to E5)  |
| Speakers for the 49 watt taps:  | _____ at 49 watts each =  | _____ watts | (E2 to E5)  |
| Speakers for the 64 watt taps:  | _____ at 64 watts each =  | _____ watts | (E1 to E5)  |
| Speakers for the 100 watt taps: | _____ at 100 watts each = | _____ watts | (E3 to E6)  |
| Speakers for the 121 watt taps: | _____ at 121 watts each = | _____ watts | (E2 to E6)  |

#### 4-Ohm Mono Speakers connected to transformer taps

|                                 |                           |             |            |
|---------------------------------|---------------------------|-------------|------------|
| Speakers for the 4 watt taps:   | _____ at 4 watts each =   | _____ watts | (E2 to E2) |
| Speakers for the 16 watt taps:  | _____ at 16 watts each =  | _____ watts | (E3 to E3) |
| Speakers for the 64 watt taps:  | _____ at 64 watts each =  | _____ watts | (E4 to E4) |
| Speakers for the 256 watt taps: | _____ at 256 watts each = | _____ watts | (E5 to E5) |

**Table 2-1. Extension Speaker Worksheet**  
*Sheet 3*

**8-OHM SPEAKERS CONNECTED TO TRANSFORMER TAPS**

Place the quantity of speakers in the blank under QTY and multiply the quantity times the power consumption (show stereo speakers as 2 speakers). Place your results in the blank under TOTAL.

**8-Ohm Stereo Speakers connected to transformer taps**

|                                | <b>QTY</b>               | <b>Total</b> | <b>Connections</b> |
|--------------------------------|--------------------------|--------------|--------------------|
| Speakers for the .5 watt taps: | _____ at .5 watt each =  | _____ watts  | (E1 to E2)         |
| Speakers for the 2 watt taps:  | _____ at 2 watts each =  | _____ watts  | (E1 to E3)         |
| Speakers for the 8 watt taps:  | _____ at 8 watts each =  | _____ watts  | (E1 to E4)         |
| Speakers for the 18 watt taps: | _____ at 18 watts each = | _____ watts  | (E3 to E5)         |
| Speakers for the 24 watt taps: | _____ at 24 watts each = | _____ watts  | (E2 to E5)         |
| Speakers for the 32 watt taps: | _____ at 32 watts each = | _____ watts  | (E1 to E5)         |
| Speakers for the 50 watt taps: | _____ at 50 watts each = | _____ watts  | (E3 to E6)         |
| Speakers for the 72 watt taps: | _____ at 72 watts each = | _____ watts  | (E1 to E6)         |
| Speakers for the 95 watt taps: | _____ at 95 watt each =  | _____ watts  | (E3 to E7)         |

**8-Ohm Mono Speakers connected to transformer taps**

|                                 |                          |             |            |
|---------------------------------|--------------------------|-------------|------------|
| Speakers for the 2 watt taps:   | _____ at 2 watt each =   | _____ watts | (E2 to E2) |
| Speakers for the 8 watt taps:   | _____ at 8 watt each =   | _____ watts | (E3 to E3) |
| Speakers for the 32 watt taps:  | _____ at 32 watt each =  | _____ watts | (E4 to E4) |
| Speakers for the 128 watt taps: | _____ at 128 watt each = | _____ watts | (E5 to E5) |

**70-VOLT SPEAKERS**

70-volt speakers have a power tap on them or on their associated transformer. Add together all of the 70-volt speaker tap settings and enter that value:

\_\_\_\_\_ watts (A1 to A2)  
\_\_\_\_\_ watts (E7 to E7)

**Table 2-1. Extension Speaker Worksheet**  
*Sheet 4*

**Combine consumptions of all speakers:**

|                      | Stereo        | Mono               |
|----------------------|---------------|--------------------|
| Connected to E1 - E7 | _____         | _____              |
| Tapped 4-Ohm:        | _____         | _____              |
| Tapped 8-Ohm         | _____         | _____              |
| 70-Volt A1, A2       | _____         | _____              |
| 70-Volt E7 to E7     |               | _____              |
|                      | <b>Stereo</b> | <b>Mono</b>        |
|                      |               | <b>Grand Total</b> |
| Totals:              | _____ + _____ | = _____            |

Subtract the Grand Total from 1000 and write the result in the blank at the end of this a0.02heS(Totals:)



**Table 2-1 Extension Speaker Worksheet**  
*Sheet 4 (Continued)*

3. The phonograph wires to change are the Violet (channel 1) and the Pink (channel 2) on the output transformer assembly (see Table 3-2A).

Use Table 3-2A as a guide to select the power used by the phonograph. This power should roughly match the amount indicated in "Power Available for the Phonograph" on the previous page.

**Table 2-2A. Phonograph Speaker Power**

| Select the speaker taps that will use up most of the "Available Speaker Power"          |   |
|---|---|
| You may select more or less phonograph power to suit your phonograph volume preference. |   |
| Phono Power <sup>1</sup>  | Phono Speaker Connections                             |
| 1   | Violet connects to Left E2, Pink Connects to Right E2 |
| 4   | Violet connects to Left E3, Pink Connects to Right E3 |
| 16  | Violet connects to Left E4, Pink Connects to Right E4 |
| 28  | Violet connects to Left E5, Pink Connects to Right E5 |
| 64  | Violet connects to Left E6, Pink Connects to Right E6 |
| 113   | Violet connects to Left E7, Pink Connects to Right E7 |
| Do not move the Black wire; it should stay on either the Left or Right E1 terminal.     |   |

**Table 2-2B. Amplifier Overload Check**



Check that the amplifier is not overloaded by performing the following four steps:

1. Make sure that the extension speakers are connected to the proper speaker taps.
2. Set the volume control to maximum volume and make a selection.
3. While the music is playing, if the OVERLOAD INDICATOR(S) stay OFF or occasionally flicker in a random manner, the load is acceptable. If the OVERLOAD INDICATOR(S) are always lit or flicker continuously, the amplifier is overloaded and will shut down, and you must perform Step 4.
4. Do this step only if the OVERLOAD INDICATOR(S) came on as described in Step 3. Find the source of the overload (shorted speaker wires, too many speakers connected, or speaker power taps too high). After you fix the short, disconnect a few speakers or lower the speaker power tap selection, then repeat Step 3.

<sup>1</sup> This value is the total for both channels. The power consumption for each channel is one-half of this value.

This page intentionally left blank.

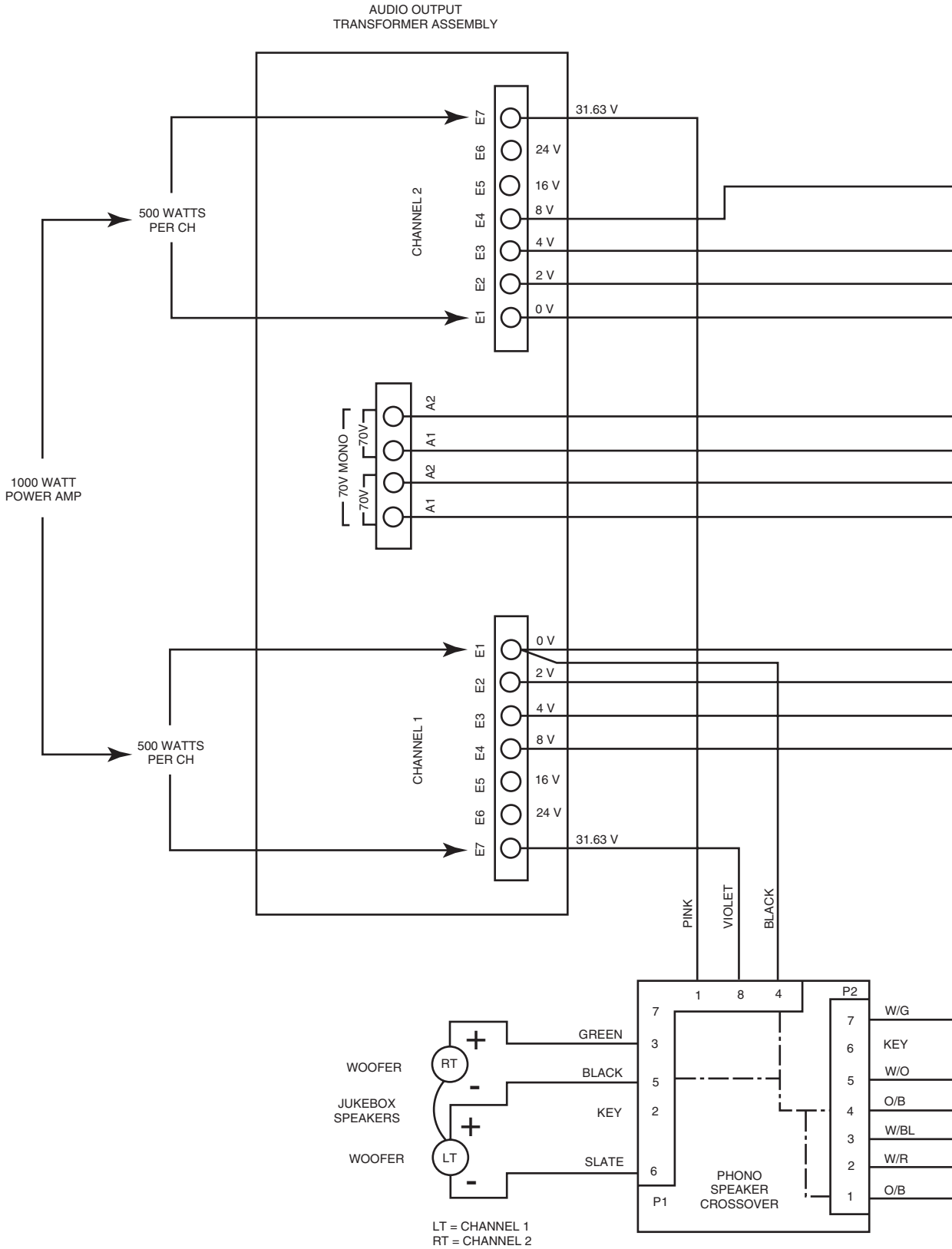

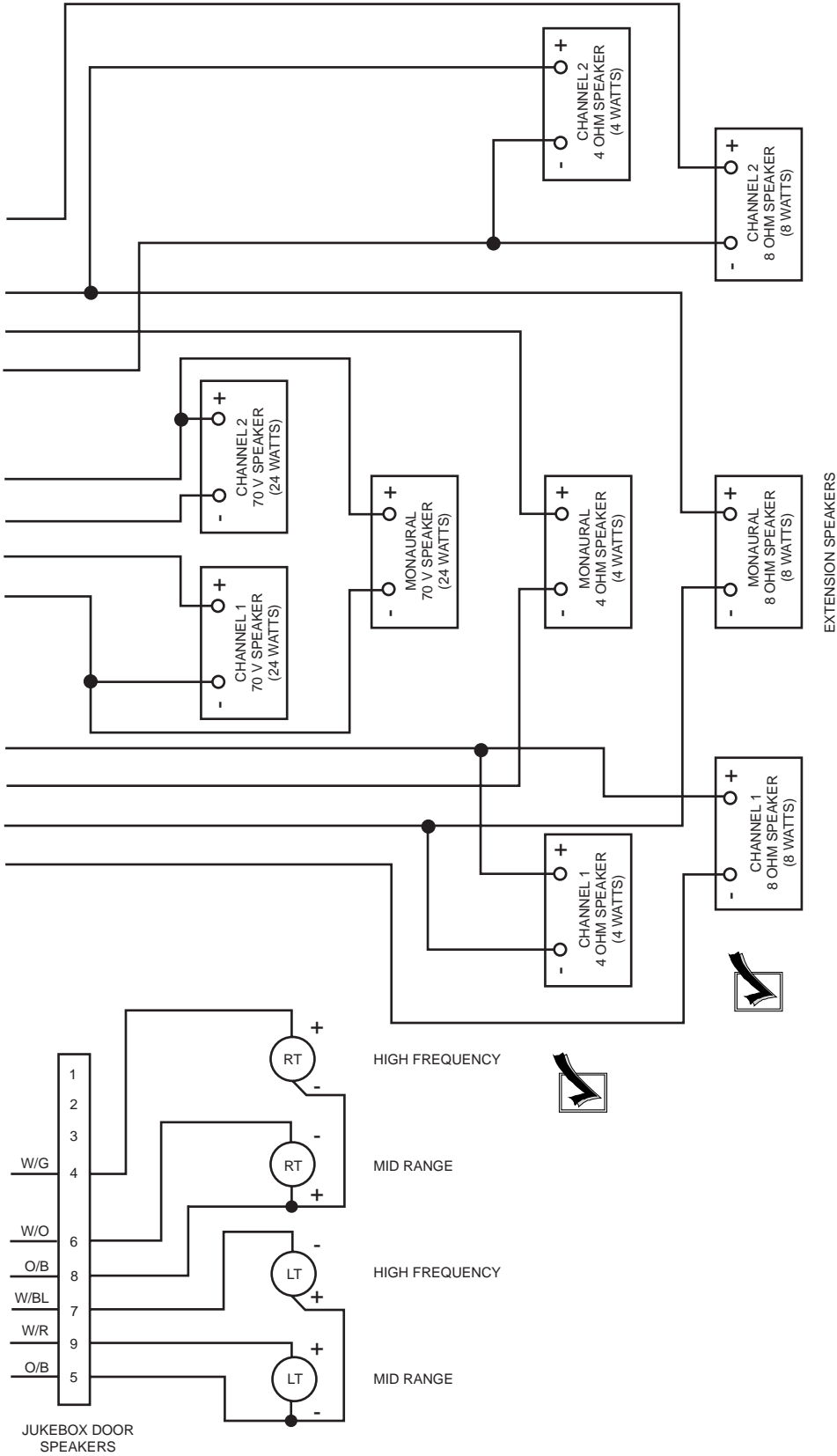
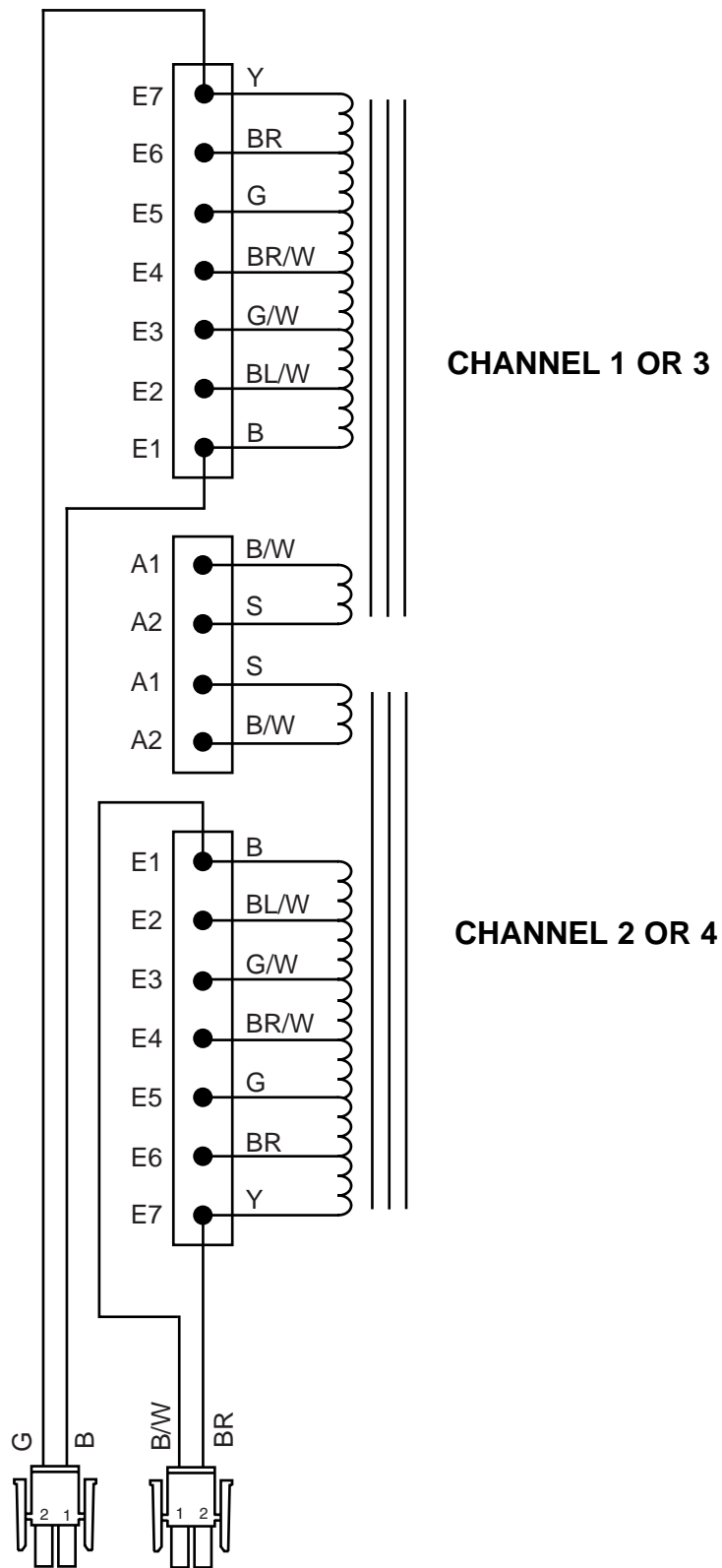

Figure 2-7. Speaker Connections



40832108 TRANSFORMER WIRING DIAGRAM

This page intentionally left blank.

## SPEAKER SYNOPSIS

### **1000 WATTS OF RMS POWER PER AMPLIFIER OR 500 WATTS PER CHANNEL.**

The generic speaker wiring diagrams cover 4 to 32 speakers. Diagram 1 has a 4 speaker layout. If you only want the four speaker layout, then the maximum output of each speaker would have to be rated 4 ohms and capable of 300 watts.

Question: Why a 300 watt rating on the speaker?

Answer: Safety factor/life of speaker.

These speakers are expensive, providing a lot of sound in a localized area which does not optimize the room sound.

A better way to distribute the sound is by adding more speakers. Diagram 2 has a layout of 8 speakers at 8 ohms each and only having a rating of 150 watts each, which includes a safety factor. The expense factor should now be less for each speaker.

For a really big room, Diagram 3 may be the best scenario. Diagram 3 shows a series/parallel hookup with up to 16 speakers. The advantage is the ratings are 4 ohms at only 75 watts each. Thus giving you a lot of sound at a reasonable price. To ensure the speakers work correctly, the 2 wired in series should be of the same make and model. Different models wired in series will not give equal outputs, and the frequency response may be strange.

Question: Too many speakers now?

Answer: Simply leave off as many speakers as you wish, as long as it is 2 at a time, which means a series combo combination.

To minimize cost, it is recommended to utilize Diagram 4. This shows 32 speakers, their rating only has to be 8 ohms at 50 watts. This allows you to use inexpensive speakers which can be found at the big electronic stores. This also provides you the chance to A/B them for sound. Try also to get the most efficient speakers.

EACH SPEAKER OUTPUT IS 250 WATTS

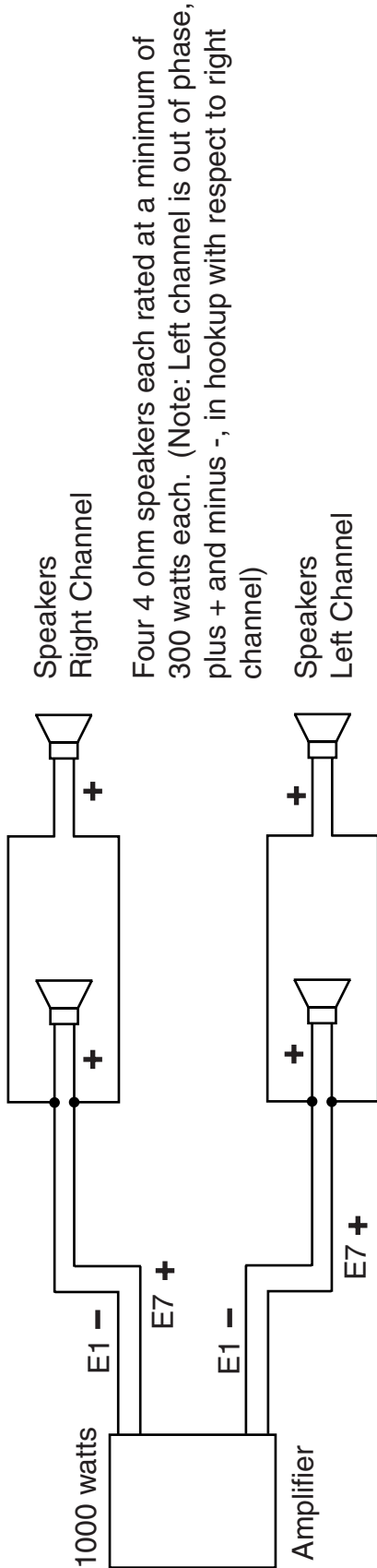
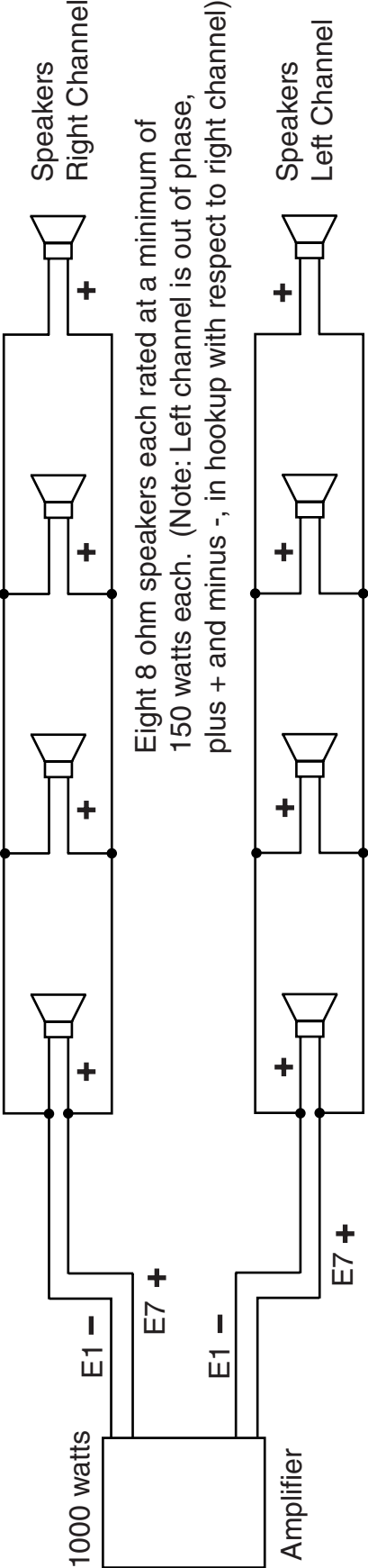

DIAGRAM 1

Speakers Right Channel

Speakers Left Channel

Eight 8 ohm speakers each rated at a minimum of 150 watts each. (Note: Left channel is out of phase, plus + and minus -, in hookup with respect to right channel)



EACH SPEAKER OUTPUT IS 125 WATTS

DIAGRAM 2



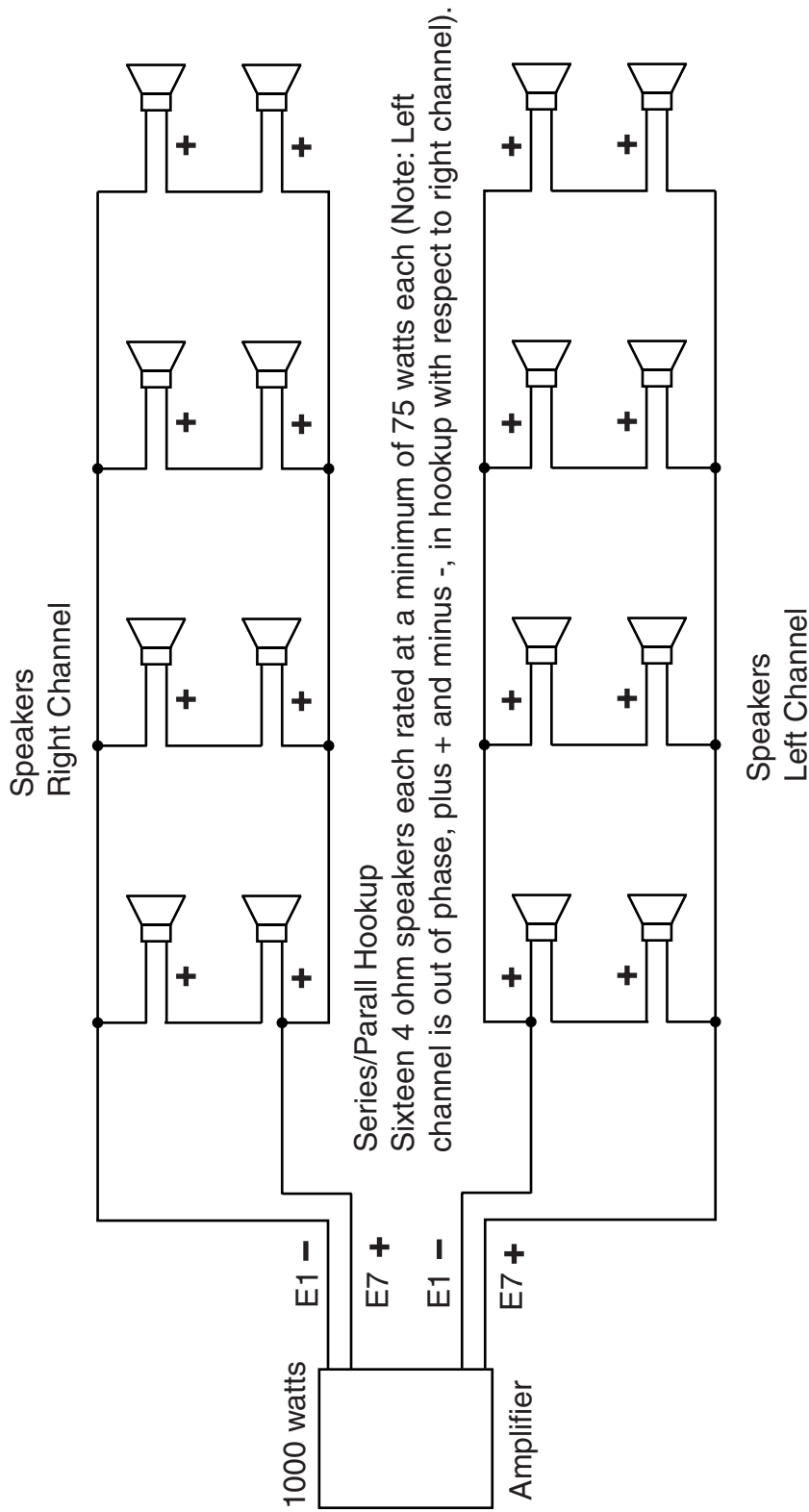

EACH SPEAKER OUTPUT IS 62.5 WATTS

DIAGRAM 3

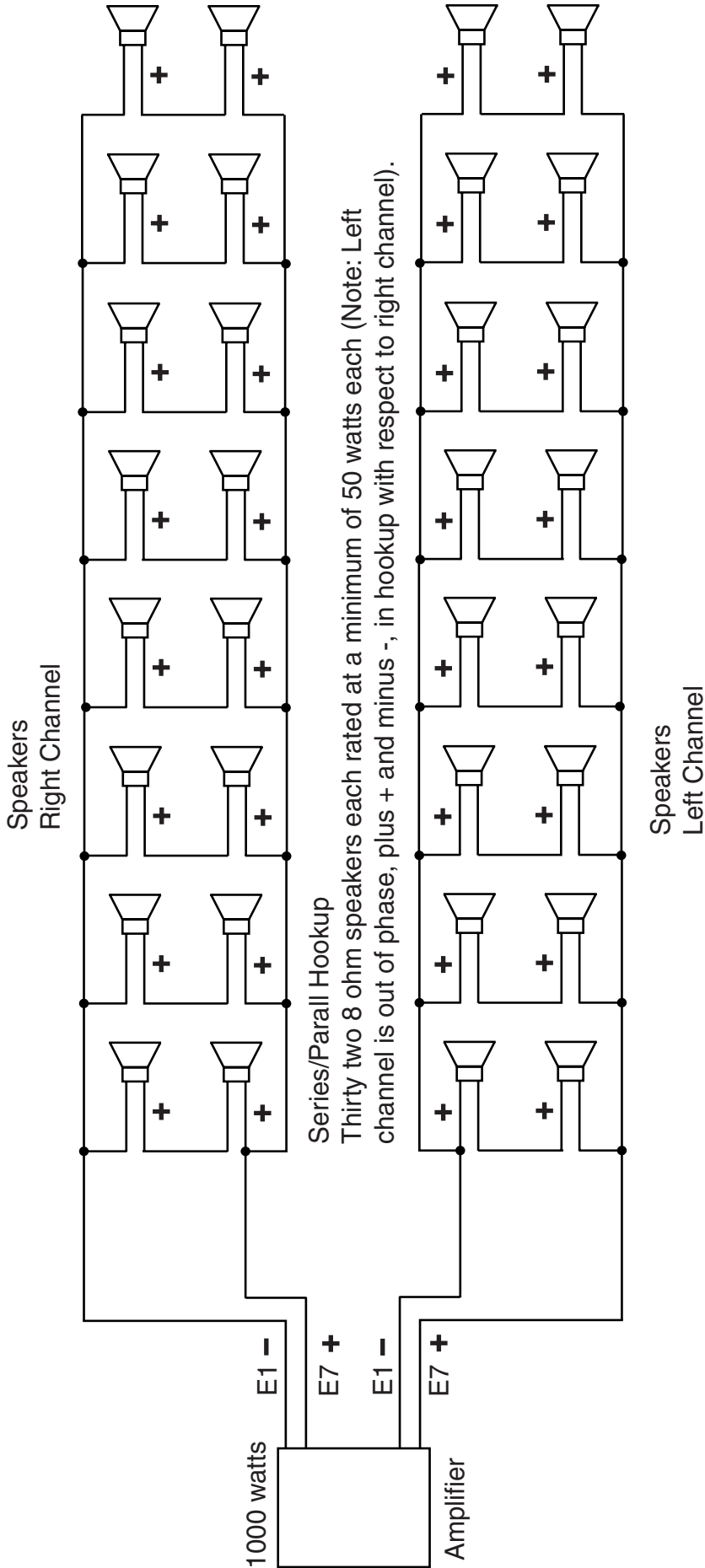

EACH SPEAKER OUTPUT IS 31.25 WATTS

DIAGRAM 4

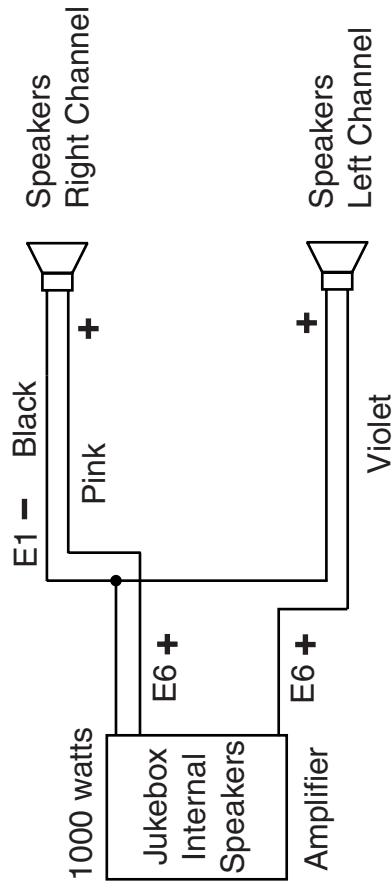
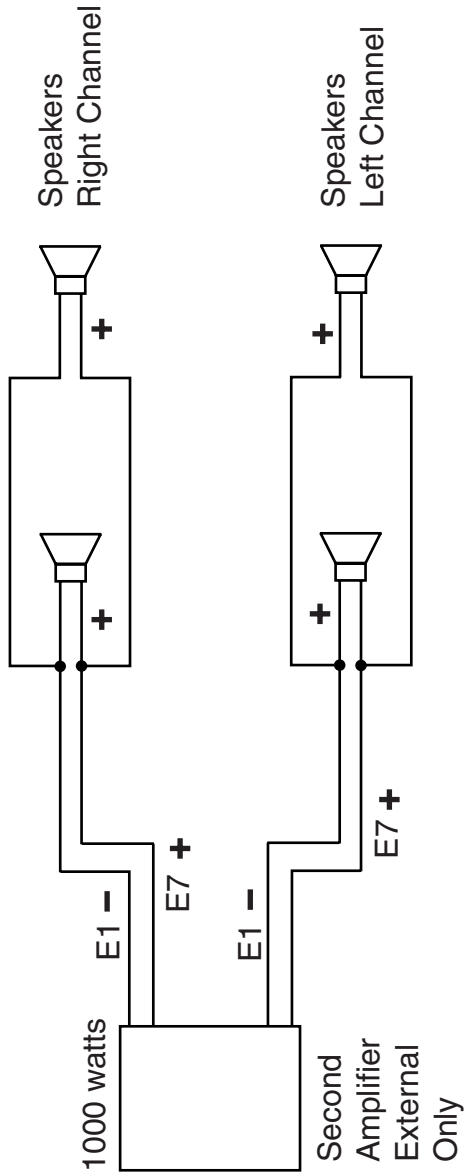

Pink and Violet connect to E6 as shown  
Black connects to E1

This page intentionally left blank.

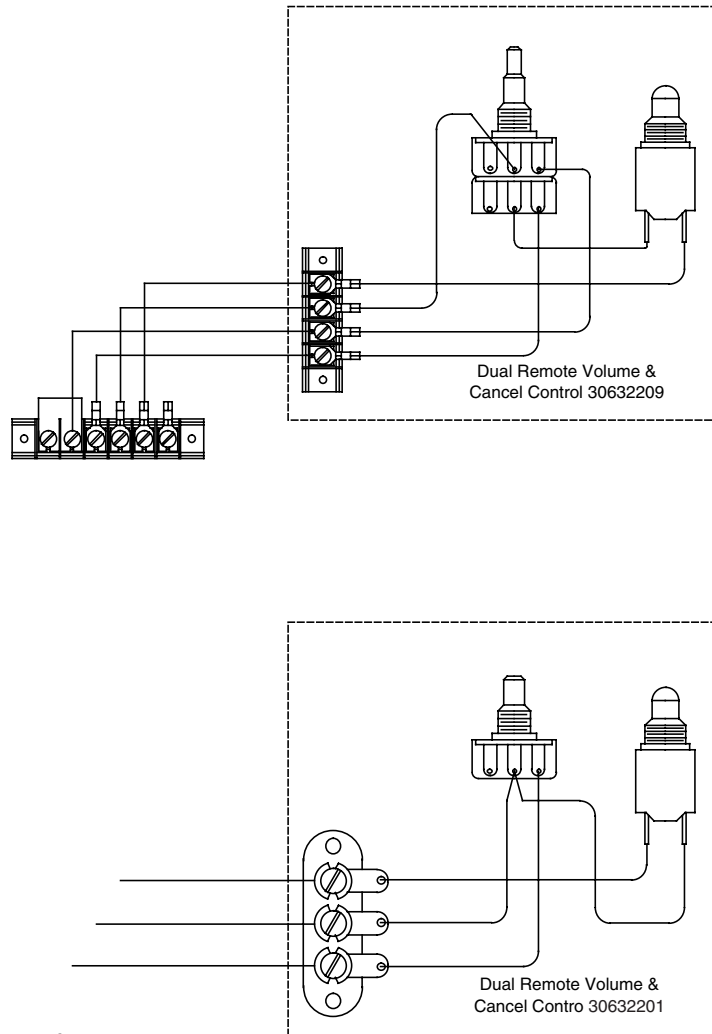

Figure 2-8A. Remote Volume Control Diagrams

## IR VOLUME CONTROL 2CH PREAMP

Volume can be controlled by a 21958307 IR transmitter and a single- or dual-wired remote control.

When the wired volume control is moved, the volume will quickly fade up or down to match its position. When moving a wired remote control, it is best to quickly turn the volume off then turn it up to the desired volume. This will eliminate a sudden loud blast if the wired remote control was set at or close to full volume.

The IR transmitter Ch1+, Ch2+, Ch1-, Ch2- keys will raise and lower the volume.

The ROWELINKRCB LED should flash continuously at approximated 20 CPS.

The IR VOL COMM LED will flash when a Ch1+, Ch2+, Ch1-, Ch2- key is pushed.

### Single Volume Control Setup

- Set terminal block jumper as shown in Figure 2-8A Remote Volume & Cancel Control 30632201.
- On 40933101 set all S1/DIP switches to OFF (refer to Figure 2-8B).
- On 40933101 plug connector into P2. P1 is left open.

### Dual Volume Control Setup

- Set terminal block jumper as shown in Figure 2-8A Dual Remote Volume & Cancel Control 30632209.
- On 40933101 set S1-1 DIP switch to ON and all others OFF (refer to Figure 2-8B).
- On 40933101 plug connector into P1. P2 is left open.

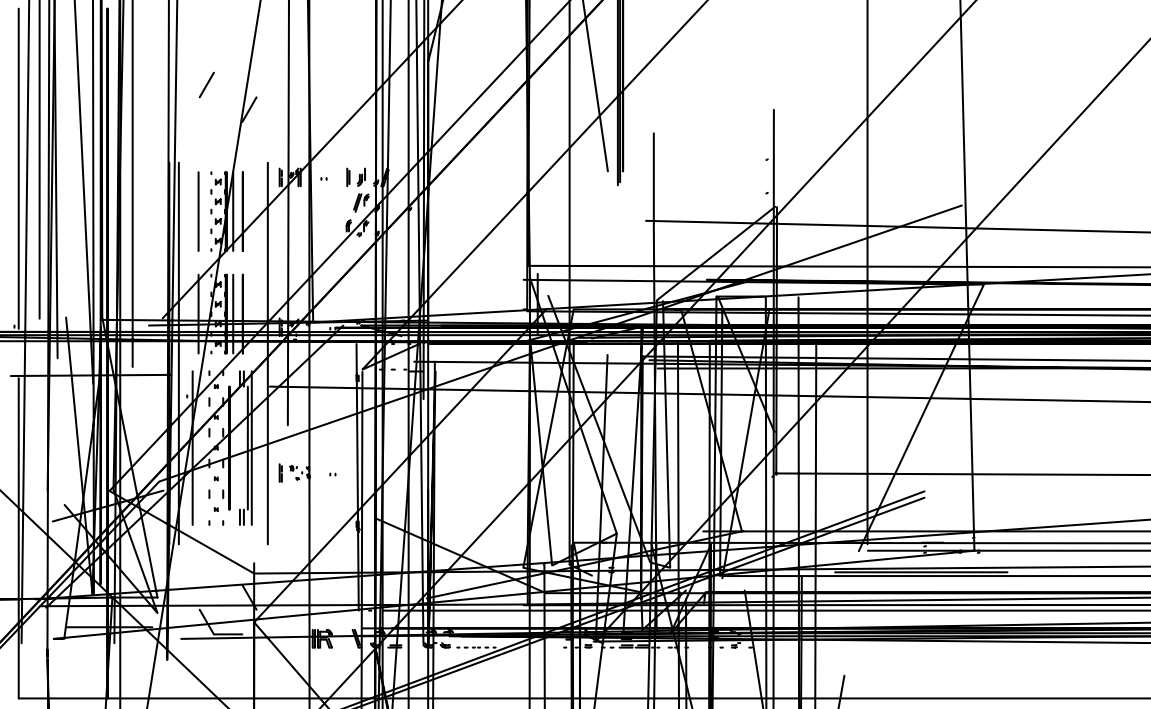

Figure 2-8B. IR Volume Control 2CH Preamp

## SOUND SYSTEM

### Acoustical Compensation (Equalizer Tone Controls)

The preamplifier contains seven tone controls on each channel to compensate for room acoustics in various locations. These controls are on the amplifier chassis. The sound level at which the phonograph will be operated and the room furnishings determine the settings of these controls.

A room with carpet and drapery is a soft or highly absorbent location. A crowded room is also highly absorbent. These location require greater emphasis of high frequencies.

A room with paneled walls and a bare or tiled floor is a hard, nonabsorbent location, which requires greater low frequency emphasis.

Regardless of the room acoustics, the high and low frequency characteristics of your speakers can influence the equalizer settings as much or more than the room acoustics.

### What This Graphic Equalizer Does

This graphic equalizer controls the tone for seven specific tone ranges. The frequency for each range is printed next to each equalizer control.



#### IMPORTANT:

- ☞ Before setting these controls, do *Steps 1-5* in *Table 2-2B* to ensure that the amplifier is not overloaded.
- ☞ Each of these controls can limit the maximum volume for its range by as much as 85%.
- ☞ This means that if a control is set to minimum, that the maximum power available for that range is only about 40 watts.
- ☞ If all of the graphic equalizer controls are set to minimum, then the phonograph will produce no more than approximately 40 watts of its 250 watt capacity.

### Equalizer Settings

These equalizers work equally well for stereo and mono sound and may be used with single and dual volume controls.

The settings that follow will give a good sound for a room with the matching acoustics (highly absorbent, moderately absorbent, nonabsorbent). Set the right and left channel equalizer controls to the positions that match the room described (or most closely described) in the three illustrations that follow this paragraph. These settings may be just right or they may not sound 100% right to you. If the sound is not satisfactory, make small changes in the settings until the sound is just the way you want it.

## If the Room or Speaker System Requires a Trade-Off

The equalizer limits the volume of all of the audio frequencies. Therefore, to achieve the best sound for a specific room or set of speakers, you may find that most of the graphic equalizer controls need to be turned down. In this situation, the overall phonograph volume may not be adequate. If you find that you have this situation, increase each graphic equalizer control slightly until the phonograph produces the required volume.

## Procedures for Adjustment

Select one of the Room Acoustics that most closely matches the acoustics of your room and follow the instructions for that room type. If your room is an average or moderately absorbent room, or you like the sound of the phonograph, you can use the factory settings just the way they are.

## Soft and Highly Absorbent Rooms

Rooms with carpet and drapery are considered to be “soft and highly absorbent.”

1. Turn all seven right channel and seven left channel graphic equalizer controls fully counterclockwise.
2. Turn the 46 and the 108 Hz controls to the position midway between the maximum and the minimum position as shown to the right. Leave all of the other controls turned all the way counterclockwise.
3. The controls on the equalizer should now be set as shown to the right.
4. Play a selection and turn the controls slightly (no more than 1/8 of a turn at a time) until the sound is acceptable. Be sure that the phonograph volume is adequate. If the volume is not adequate, turn each control up (counterclockwise) slightly until the volume is satisfactory.

**Remember: The maximum volume setting is obtained when all controls are turned full counterclockwise.**

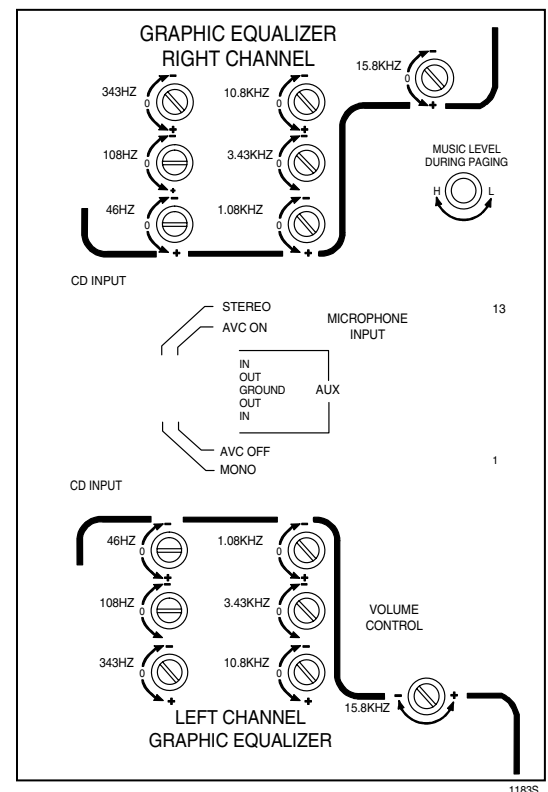

**Figure 2-9A. “Soft” Rooms**



## Average or Moderately Absorbent Rooms

These are the factory settings.

1. Turn all seven right channel and seven left channel graphic equalizer controls fully counterclockwise.
2. The graphic equalizer's controls should now be set as shown to the right.
3. Play a selection and turn the controls slightly (no more than 1/8 of a turn at a time) until the sound is acceptable. Be sure that the phonograph volume is adequate. If the volume is not adequate, you will need to turn each control up (counterclockwise) slightly until the volume is satisfactory.

**Remember: The maximum volume setting is obtained when all controls are turned full counterclockwise.**

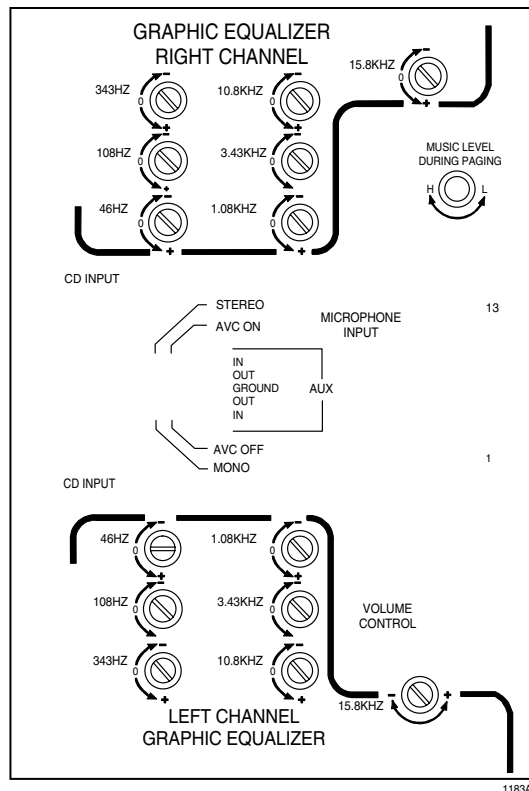

Figure 2-9B. "Average" Rooms

## Hard or Non-Absorbent Rooms

Rooms that are paneled and have bare or tiled floors are considered to be "hard or nonabsorbent."

1. Turn all seven right channel and seven left channel graphic equalizer controls fully counterclockwise.
2. Turn the 15.8 kHz control all the way clockwise as shown to the right.
3. Turn the 10.8 kHz control to the position midway between the maximum and minimum position as shown to the right. Leave the 46 Hz, 108 Hz, 343 Hz, 1.08 kHz, and 3.43 kHz controls turned all the way counterclockwise.
4. The controls on the equalizer should now be set as shown to the right.
5. Play a selection and turn the controls slightly (no more than 1/8 of a turn at a time) until the sound is acceptable. Be sure that the phonograph volume is adequate. If the volume is not adequate, you will need to turn each control up (counterclockwise) slightly until the volume is satisfactory.

**Remember: The maximum volume setting is obtained when all controls are turned full counterclockwise.**

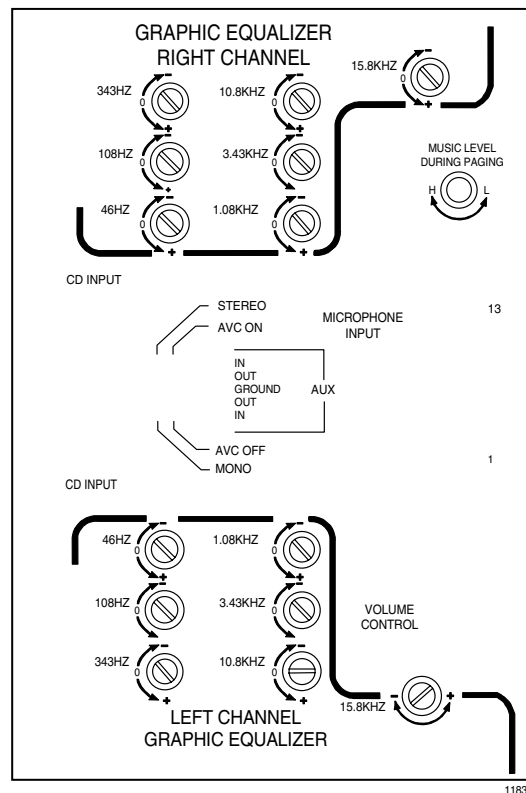

Figure 2-9C. "Non-Absorbent" Rooms

## Paging

Paging circuitry is part of the Preamplifier. The Microphone cable plugs directly into the preamplifier.

## CHANGING THE NUMBER OF CREDITS REMAINING

Use these steps to increase or decrease the number of CREDITS REMAINING on the phonograph.

1. Enter the SERVICE mode by pulling the SERVICE button out to the SERVICE position.
2. Type 84, then type the number of CREDITS REMAINING that you want. Press POPULAR to complete the change.

## ENTERING THE SERVICE MODE

Menus can only be used while the phonograph is in the SERVICE mode. To enter the SERVICE mode, open the top door and pull the SERVICE button out (*Figure 2-4*) to the SERVICE position.

When the phonograph is placed into the SERVICE mode, the message \*SERVICE MODE\* appears on the digital display

## If You “Get Lost” in the Menus

Since the menu mode of pricing and programming does not require you to use any reference material, you may (occasionally) find that you have ventured down the wrong menu and that you don't know what option is next. To correct this situation, perform the following steps:

1. Press and hold down RESET and press 0 until you come to the top of current menu.
2. If this menu name doesn't help, press and hold RESET and press POPULAR. This will move you to the top of the previous menu. In most cases, this will return you to the main menu ( \* SERVICE MODE \* ).
3. If you still cannot determine where you are, press and hold RESET and press POPULAR again. Repeat this step until you get to the main menu ( \* SERVICE MODE \* ).

## USING CD-100K COMMANDS

CD-100K commands are formed by combining the numbers that appear on the left side of the menus in *Figure 2-10*. To construct and use CD-100K commands, refer to *Figure 2-10* or *Table 2-4*.

**Example:** You want to view the number of cycles the CD mechanism has made. Using *Figure 2-10*, you determine that you need to select AUDITS (1) on the main menu; NON-RESETTABLES (2) on the AUDIT menu; and MECH (7) on the NON-RESETTABLES menu. Use the digits to form a numeric command, which is 127. Type 127 and the number of mechanism cycles is displayed.



### NOTE:

To use the command mode effectively, return to the main menu after each command is completed. Do this by holding RESET down and pressing POPULAR until the words \*SERVICE MODE\* appear on the digital display.

## Combining Menu and Modes

The most efficient way to set pricing and change programming is to use a combination of the menu mode and the command mode to move through the menus. To do this, use the command mode to get to the command you want to use, execute the command, and use the menu mode to go to your next selection.

This page intentionally left blank.

**CD SERIES  
SERVICE  
MODE  
MAP**

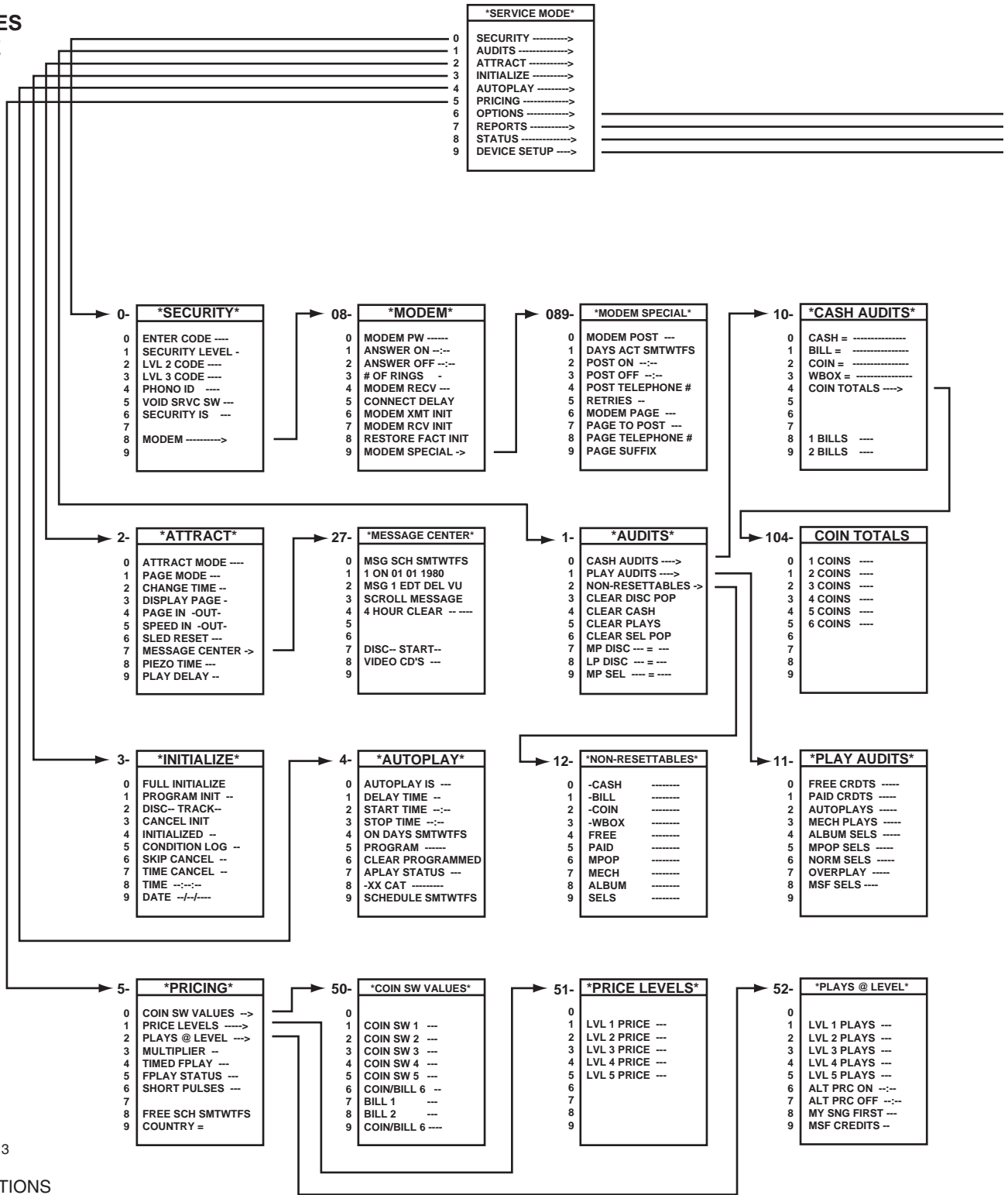

Version 2.3

**KEY FUNCTIONS**

- RESET + 0 ----> Move up 1 line
- RESET + 1 ----> Move down 1 line
- RESET + 2 ----> Move left, decrement
- RESET + 3 ----> Move right, increment
- RESET + 4 ----> Delete
- RESET + 5 ----> Insert
- RESET + 7 ----> Negate
- RESET + 8 ----> Copy
- RESET + 9 ----> Toggle/Next
- RESET + POPULAR ----> Escape/Backup
- POPULAR ----> Enter

NOTE: A line beginning with an \* is the title of a page. A line ending with ----> indicates another page exists.

**Figure 2-10. Service Mode Map**

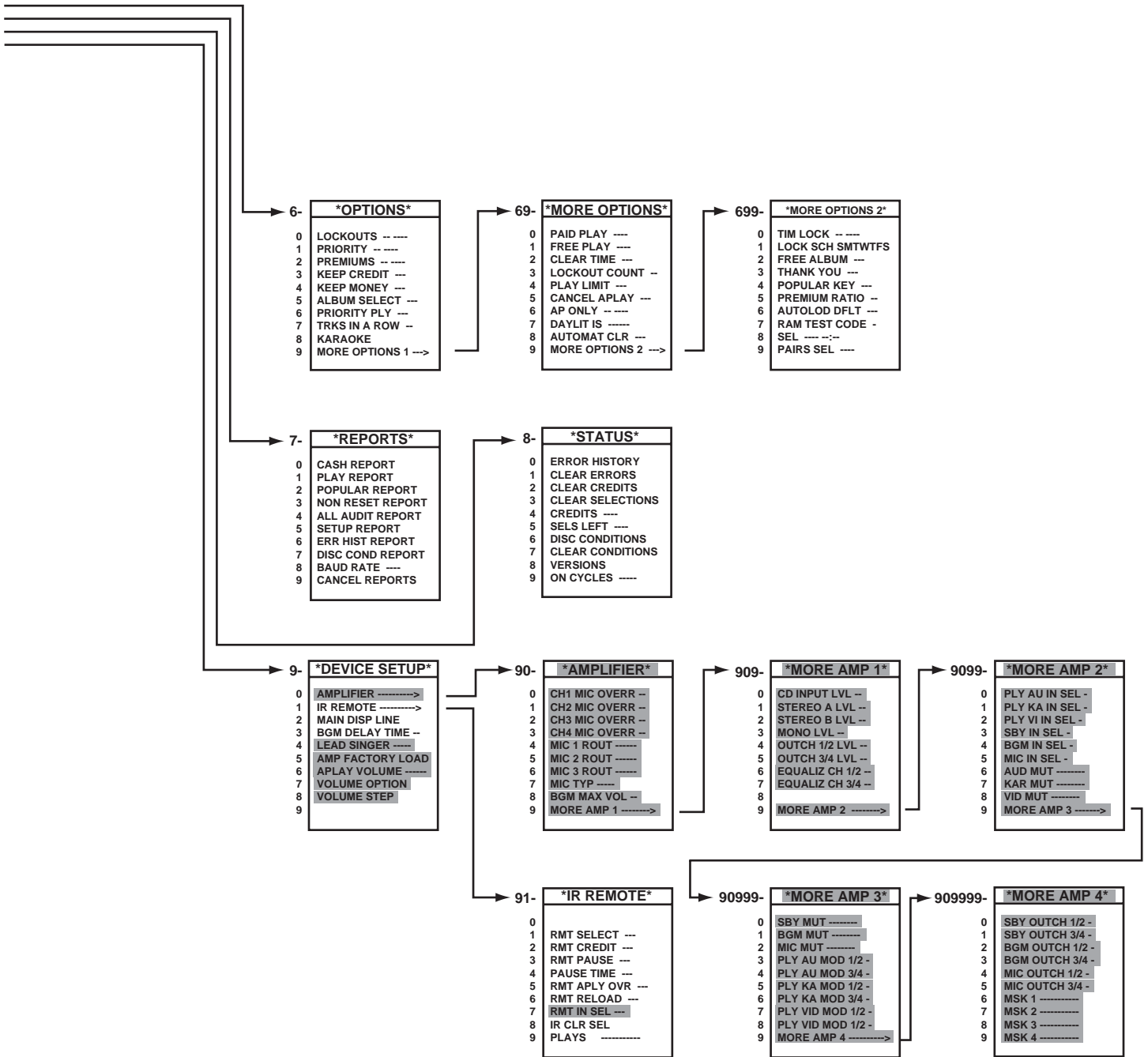

NOTE: Shaded menu items are used only with the 4-channel AV Control and the Volume Control Unit (Studio Sound Package.)

## **Service Mode Menu**

The SERVICE MODE menu (referred to as the “MAIN menu”) is the starting point for all service, pricing, and programming functions. This menu contains the general title for each submenu. Some of the submenus contain commands only. Other submenus contain both commands and further submenu names. Refer to *Figure 2-10*, the *CD-100K Service Mode Map*, for an illustration of the following menu descriptions:

## **Security Menu**

This menu contains all of the command options that must be executed to display or change a phonograph security code or enter a security level. This menu also contains a command to change the phonograph ID.

The last SECURITY option, the VOID SERVICESWITCH option, allows you to completely close the phonograph door (which places the SERVICE switch in the NORMAL position) and remain in the SERVICE mode.

## **Modem Menu**

This menu contains the programming options for setting up the modem communication.

## **Audits Menu**

The AUDITS menu allows you to display and clear the various cash, play, and popularity totals that are routinely reset when money is collected.

To enter this menu from the MAIN menu: Type 1.

## **Attract Mode Menu**

Attract mode is designed to draw attention to customers by moving the selection pages.

To enter this menu from the MAIN menu: Type 2.

## **Message Center Menu**

This menu contains the message center day scheduler, date scheduler, and message editor.

## **Initialize Menu**

This menu controls the type of CD initialization that is to be done whenever a disc is changed or moved to a new disc number. This menu must be used to identify empty CD mechanism slots.

This menu also contains options to change the phonograph’s time and date.

**NOTE:**

The phonograph will automatically adjust the disc limits whenever a disc is played. This form of initialization is not recommended as a substitute for the selections in this menu.

To enter this menu from the MAIN menu: Type 3.

**Autoplay**

Autoplay is the function that plays CD's when no customers have made selections. Autoplay can be used to stimulate play or provide background music. This feature can be scheduled and customized from the Autoplay menu.

To enter this menu from the MAIN menu: Type 4.

**Pricing Menu**

This menu allows you to change the pricing structure, select FREE PLAY, return to the factory (default) pricing, or set up the "My Song First" feature.

To enter this menu from the MAIN menu: Type 5.

**Options Menu**

This menu is a collection of disc selection options that allow you to:

- Prevent playing a track (Lockout)
- Give certain tracks priority play
- Charge a double price for certain selections
- Retain credits during a power failure
- Retain the current money total during a power failure
- Buy an entire album
- Limit the number of tracks that can be played from a disc before another disc is allowed to play.
- Retain or erase selections waiting to play if power is off for a significant interval of time, such as overnight (internally programmable from 0 to 999 minutes).

To enter this menu from the MAIN menu: Type 6.



## More Options 1 Menu

This menu is a collection of options that allows you to:

- Select FIFO or random playback of selections
- Automatically lockout defective discs (Lockout Count)
- Cancel Autoplay when a paid selection is made
- Use certain discs for Autoplay only (locked out from the keyboard)
- Automatic or manual Daylight Savings Time correction

## More Options 2 Menu

This menu allows you to:

- Use timed lockouts
- Enable or disable the “Thank You” message
- Enable or disable album buys in FREE PLAY mode
- Enable or disable making most popular selections

## Reports Menu (Optional)

The REPORTS options allow you to connect a printer or a personal computer to the RS-232 connector on the CCC. This information is the same information that can be displayed on the keyboard display, except that it has been arranged in a simple report format that can be printed or stored on a disk or diskette.

To enter this menu from the MAIN menu: Type 7.

## Status Menu

This menu allows you to display and clear the various phonograph error messages, clear and set credits, clear selections, display and clear disc condition messages, and display software versions and the number of power ON/OFF cycles.

To enter this menu from the MAIN menu: Type 8.

## Device Setup Menu

This menu allows you to set up various amplifier, volume control, and IR Remote options.

To enter this menu from the MAIN menu: Type 9.

## HOW TO MAKE PROGRAMMING CHANGES

The CD-100K allows you to perform programming activities in two ways.

The primary or MENU mode uses menus to move through the choices until you find the desired function. This method of selecting the function you want is more time consuming than the Command mode, but it does not require you to remember any commands.

The Command mode uses two- and three-digit commands to tell the phonograph what function you want to perform. The Command mode requires you to know exactly what command you want, because you will go straight to the function requested without receiving any intermediate prompts (as you would in the menu mode).

### Keyboard Controls

The POPULAR and RESET buttons on the selector keyboard (*see Figure 1-1 if you are not familiar with the selector keyboard or digital display*) are used to tell the phonograph how to use the digits that you are about to enter.

Table 2-3 describes the results of using these buttons.

**Table 2-4. Keyboard Controls**

| Keys Pressed                         | Results  |
|--------------------------------------|--|
| POPULAR                              | Completes a transaction  |
| RESET + 0<br>(hold RESET down)       | Moves you up one item in a menu  |
| RESET + 1<br>(hold RESET down)       | Moves you down one item in a menu  |
| RESET + 2<br>(hold RESET down)       | Moves you left, or decrements  |
| RESET + 3<br>(hold RESET down)       | Moves you right, or increments   |
| RESET + 4<br>(hold RESET down)       | Removes an entry (such as a programmed Autoplay entry) from the list                     |
| RESET + 5<br>(hold RESET down)       | Makes a space in a list (such as programmed Autoplay) so new information can be inserted |
| RESET + 9<br>(hold RESET down)       | Toggles between two possible selections  |
| RESET + POPULAR<br>(hold RESET down) | Cancels the current activity or moves you back to the previous menu title                |

## Security Levels

The CD-100K uses security levels to protect audit and programmable information.

- Level 1 allows you to view all of the phonograph information, except the security codes, but does not allow you to change any of the information.
- Level 2 allows you to review all of the information, except the security codes, and clear the audit information.
- Level 3 allows you to view, clear, or change any information.

## Factory Security Level

The phonograph is shipped from the factory with SECURITY OPTION (06) set to OFF.



### NOTE:

When the **SECURITY OPTION (06)** is set to **OFF**, **Security Level 3** is automatically established whenever the phonograph is in the **SERVICE MODE**.

If you set Security ON, Level 1 is established whenever the phonograph is put in the SERVICE MODE, and you must enter the proper four-digit security code to change to Level 2 or Level 3.



### NOTE:

The **SECURITY** option should be left **OFF**, unless you need security to prevent tampering with your music programming, pricing, or phonograph options.

Table 2-5A and Table 2-5B, which follow, describes the commands and how to make programming changes.

## Loading Factory Settings

After replacing the CCC EPROM:

1. Turn POWER switch on back of phonograph OFF and pull the SERVICE button out to the SERVICE position.
2. Turn POWER switch ON and within three seconds press and hold the red S1 FACTORY BUTTON on the CCC. Hold the button down until the display shows LOADING DEFAULTS.

Do not be concerned when a 14-04 WARNING appears because it is just a status message indicating that the defaults were loaded. For a fresh start, clear out this warning (service mode menu item 81).

**Table 2-5A. Menu & Command Descriptions**

| Code                    | Description   |
|-------------------------|---|
| <b>* SERVICE MODE *</b> | - Is the title of the MAIN menu. This menu is the beginning menu for all the other menus. All of the options in this menu are names for other menus. The table that follows contains descriptions of all of the menu options. Enter two-, three-, four-, five-, or six-digit commands from the <b>* SERVICE MODE *</b> display.   |
| <b>0</b>                | <b>SECURITY</b> - Contains options to access and change the security levels and to change the phonograph I.D. All security code changes must be made from Security Level 3.   |
| <b>00</b>               | <b>Enter Code</b> - Allows you to enter a security code. If the security code that you enter matches either the Level 2 or Level 3 Security Code, the phonograph will go to that security level after you press POPULAR. If both Security Level 2 and Level 3 have the same code (the factory-set code for both levels is 0000), then Level 3 is allowed. When the new security level is attained, the phonograph will automatically go to COMMAND01 and display the new security level.  |
| <b>01</b>               | <b>Security Level</b> - Displays the current security level. This command can be used at any time to determine the security level. The phonograph automatically moves to this option and displays the new security level after you successfully enter a security code (see COMMAND00).  |
| <b>02</b>               | <b>Level 2 Security Code</b> - Displays the Level 2 Security Code and allows the security code to be changed by entering new data, then pressing POPULAR. The phonograph must be in Security Level 3 for either of these selections to function. Write the new security code down and keep it in a safe, but accessible place. No one will be able to access Level 2 if the SECURITY OPTION 06 is turned ON and you lose the security code. This security level is intended to be used by the route man, so that he can read cash totals, reset cash totals, and initialize the phonograph. The Route man cannot change pricing or programming. |
| <b>03</b>               | <b>Level 3 Security Code</b> - Displays the Level 3 Security Code and allows the security code to be changed by entering new data, then pressing POPULAR. The phonograph must be in Security Level 3 before this code can be displayed or changed. Write the new security code down and keep it in a safe, but accessible place. No one will be able to access Level 3 or change the security code if SECURITY OPTION 06 is turned ON and you lose the security code.   |
| <b>04</b>               | <b>Phonograph I.D.</b> - Displays the current phonograph I.D. code and allows the I.D. to be changed by entering new data, then pressing POPULAR. The phonograph must be in Security Level 3 before the I.D. can be changed. It may be viewed in Security Level 1.  |
| <b>05</b>               | <b>Void Service Switch</b> - Allows the top door of the phonograph to be closed (which normally places the SERVICE switch back into the NORMAL mode) and still remain in the SERVICE mode. Press and hold RESET. Press 9 to toggle the option ON and OFF. Press POPULAR to save the change. This option must be OFF to resume normal operation.   |

**Table 2-5A. Menu & Command Descriptions***Continued*

| Code | Description   |
|------|---|
| 06   | <b>Security On/Off</b> - If set to OFF, Security Level 3 is automatically established when entering the SERVICE MODE. When security is set to ON, Level 1 is established when SERVICE MODE is entered and the proper four-digit security code must be entered to access Security Level 2 or 3. Leave security OFF, unless you need security to prevent tampering. Hold RESET and press 9 to select ON or OFF. Press POPULAR to save your choice. Security can be turned ON from any security level, but can only be turned OFF in Security Level 3. |
| 07   | <b>Not used</b>   |
| 08   | <b>MODEM</b> - Contains the programming options for setting up the modem communications.  |
| 080  | <b>Modem Password</b> - This password is used when calls are received from the office. Enter the 7-digit password, and push POPULAR.  |
| 081  | <b>Answer On Time</b> - The time to enable calls to be received from the office (if menu item 084 is ON). Enter the hour and push POPULAR. Enter the minute and push POPULAR.   |
| 082  | <b>Answer Off Time</b> - The time to disable calling from the office. Enter the hour and push POPULAR. Enter the minute and push POPULAR.   |
| 083  | <b># of Rings to Answer On</b> - The number of times the phone will ring before it is answered by the modem (if menu item 084 is ON). Enter the # and push POPULAR.   |
| 084  | <b>Modem Receive</b> - If set to ON, calls will be answered by the modem. If set to OFF, no calls will be answered by the modem. Hold RESET and push 9 to set ON or OFF, then push POPULAR.   |
| 085  | <b>Connect Delay Time</b> - If modem is in Receive Mode, this is the time in seconds to delay between the CONNECT 9600 message and the PASSWORD message. For Post Error/Report Mode, it is the time in seconds to delay between the CONNECT 9600 message and the start of the Report or Error message. Enter the time in seconds and push POPULAR.  |
| 086  | <b>Modem Transmit Initialize String</b> - This is the initialization string sent to the modem before the modem will page or post to the office (if menu items 0890 and/or 0896 and/or 0897 are ON). Push POPULAR to display the string. See <i>Editing Numbers/Strings</i> to modify the string.  |
| 087  | <b>Modem Receive Initialize String</b> - This is the initialization string sent to the modem before the modem will answer a call from the office (if menu items 084 is ON). Push POPULAR to display the string. See <i>Editing Numbers/Strings</i> to modify the string.  |
| 088  | <b>Restore Modem Factory Initialization Strings</b> - Resets strings at menu items 086 and 087. Also resets telephone nos. and suffix at menu items 0894, 0898, and 0899. Press POPULAR to perform this function.   |

**Table 2-5A. Menu & Command Descriptions***Continued*

| Code        | Description  |
|-------------|--|
| <b>089</b>  | <b>MODEM SPECIAL</b> - Modem Special is a continuation of the MODEM menu.  |
| <b>0890</b> | <b>Modem Post Reports to a PC</b> - If set to ON, the modem will call the office and send reports on the days that are active in menu item 0891. If set to OFF, the modem will not call the office. Hold RESET and push 9 to set ON or OFF, then push POPULAR.   |
| <b>0891</b> | <b>Days Posting Is Active</b> - Allows you to select the days of the week that the modem will call the office if menu item 0890 is ON. Hold RESET and press either 2 or 3 to move from day to day. The day currently selected will blink. Hold RESET and push 9 to turn the day ON or OFF. Push POPULAR to save any changes.                       |
| <b>0892</b> | <b>Post On Time</b> - The time to enable posting calls to the office (if menu item 0890 is ON). Enter the hour and push POPULAR. Enter the minute and push POPULAR.  |
| <b>0893</b> | <b>Post off Time</b> - The time to disable posting calls to the office. Enter the hour and push POPULAR. Enter the minute and push POPULAR.  |
| <b>0894</b> | <b>Post Telephone Number</b> - This is the telephone number of the office dialed by the modem. Push POPULAR to display the number. See <i>Editing Numbers/Strings</i> to modify the telephone number.  |
| <b>0895</b> | <b>Post and Page Retries</b> - The number of times the modem will repeat a page or the number of times the modem will redial the office if the modem didn't connect with the office modem. Enter the # and push POPULAR.   |
| <b>0896</b> | <b>Modem Page (Errors to a Pager)</b> - If set to ON, the modem will call a pager in the event of the phonograph going OUT OF ORDER or the bill acceptor goes OUT OF ORDER. The number the modem dials is at menu item 0898. If set to off, the modem will not call a pager. Hold RESET and push 9 to set ON or OFF, then push POPULAR.            |
| <b>0897</b> | <b>Modem Page to Post (Errors to a PC)</b> - If set to ON, the modem will call the office in the event of the phonograph going OUT OF ORDER or the bill acceptor goes OUT OF ORDER. The number the modem dials is at menu item 0894. If set to off, the modem will not call the office. Hold RESET and push 9 to set ON or OFF, then push POPULAR. |
| <b>0898</b> | <b>Pager Telephone Number</b> - This is the telephone number of the pager dialed by the modem. Push POPULAR to display the number. See <i>Editing Numbers/Strings</i> to modify the telephone number.  |
| <b>0899</b> | <b>Pager Suffix String</b> - This is the suffix string that may be required by the pager. It is sent following the numerical message. Push POPULAR to display the string. See <i>Editing Numbers/Strings</i> to modify the string.   |
| <b>09</b>   | <b>Serial No</b> - Displays phono serial no.   |

**Table 2-5A. Menu & Command Descriptions***Continued*

| Code | Description  |
|------|--|
| 1    | <b>AUDITS</b> - Are the functions and menus that allow you to display and reset the various accumulated figures for money, popularity, number of plays, and credits.   |
| 10   | <b>CASH AUDITS</b> - Is the menu that allows you to display, but not change, cash totals, number of coins through the coin switches, and the total number of bills.  |
| 11   | <b>PLAY AUDITS</b> - Is the menu that allows you to display, but not change, credits, autoplays, mechanism plays, and album plays.   |
| 12   | <b>NON-RESETTABLES</b> - Is the menu that allows you to display the ongoing totals. These totals cannot be reset from any security level.  |
| 13   | <b>Clear Disc Popularity</b> - Clears the popularity for all discs. This option should only be used after the popularity figures (Selections 7 and 8 in this menu) have been read and recorded. Press POPULAR to perform this function. The display will blink when the command is executed.   |
| 14   | <b>Clear Cash</b> - Clears all current cash totals. This option should only be used after the figures for Cash Audits (Selection 0 in this menu) have been read and recorded. Press POPULAR to perform this function. The display will blink when the command is executed.   |
| 15   | <b>Clear Plays</b> - Clears all current play totals. This option should only be used after the Play Audit figures in Play Audits (Selection 1 in this menu) have been read and recorded. Press POPULAR to perform this function. The display will blink when the command is executed.  |
| 16   | <b>Clear Selection Popularity</b> - Clears all current selection popularity. This option should only be used after Popularity Figures (Selection 9 in this menu) have been read and recorded. Press POPULAR to perform this function. The display will blink when the command is executed.   |
| 17   | <b>Display the Most Popular Disc</b> - Displays the most popular disc number (00-99) followed by the number of plays (9999 maximum) that disc had. To display the next Most Popular disc, press and hold RESET and then press 3. Press and hold RESET and then press 3 to display each successive most popular disc. Press and hold RESET and then press 2 to move up through the popularity display toward the most popular disc. You can request the popularity for a particular disc by pressing the disc number. |
| 18   | <b>Display the Least Popular Disc</b> - Displays the least popular disc number (00-99) followed by the number of plays that the disc had. To display the next Least Popular disc, press and hold RESET and then press 2. Press and hold RESET and then press 2 to display each successive least popular disc. Press and hold RESET and then press 3 to move up through the popularity display toward the least popular disc. You can request the popularity for a particular disc by pressing the disc number.       |





**Table 2-5A. Menu & Command Descriptions***Continued*

| Code                        | Description   |
|-----------------------------|---|
| <b>1041</b>                 | <b>Current Number of Type 2 Coins</b> - Displays the total number of Type 2 coins (10¢) collected since the last time the CLEAR CASH command (Selection 4 in the AUDITS menu) was used.   |
| <b>1042</b>                 | <b>Current Number of Type 3 Coins</b> - Displays the total number of Type 3 coins (25¢) collected since the last time the CLEAR CASH command (Selection 4 in the AUDITS menu) was used.   |
| <b>1043</b>                 | <b>Current Number of Type 4 Coins</b> - Displays the total number of Type 4 coins (50¢) collected since the last time the CLEAR CASH command (Selection 4 in the AUDITS menu) was used.   |
| <b>1044</b>                 | <b>Current Number of Type 5 Coins</b> - Displays the total number of Type 5 coins collected since the last time the CLEAR CASH command (Selection 4 in the AUDITS menu) was used.   |
| <b>1045</b>                 | <b>Current Number of Type 6 Coins</b> - Displays the total number of Type 6 coins collected since the last time the CLEAR CASH command (Selection 4 in the AUDITS menu) was used. (Menu Item 509 must be COIN if coin SW 6 used as coin input.) |
| <b>1046 - 1049 Not Used</b> |   |
| <b>11</b>                   | <b>PLAY AUDITS</b> - Allows you to display, but not change, credits, autoplays, mechanism plays, and album plays.   |
| <b>110</b>                  | <b>Free Credits</b> - Displays the number of free credits given since the last time the CLEAR PLAYS command (Selection 5 in the AUDITS menu) was used.  |
| <b>111</b>                  | <b>Paid Credits</b> - Displays the number of paid credits given since the last time the CLEAR PLAYS command (Selection 5 in the AUDITS menu) was used.  |
| <b>112</b>                  | <b>Autoplays</b> - Displays the number of Autoplays made since the last time the CLEAR PLAYS command (Selection 5 in the AUDITS menu) was used.   |
| <b>113</b>                  | <b>Mechanism Plays</b> - Displays the number of times the mechanism has played CD's since the last time the CLEAR PLAYS command (Selection 5 in the AUDITS menu) was used.  |
| <b>114</b>                  | <b>Album Buys</b> - Displays the number of times albums have been bought since the last time the CLEAR PLAYS command (Selection 5 in the AUDITS menu) was used.   |
| <b>115</b>                  | <b>Most Popular Plays</b> - Displays the number of times that the POPULAR button was used to select the most popular selection since the last time the CLEAR PLAYS command (Selection 5 in the AUDITS menu) was used.                           |
| <b>116</b>                  | <b>Normal Selections</b> - Displays the number of selections made from the keyboard.  |

**Table 2-5A. Menu & Command Descriptions***Continued*

| Code | Description  |
|------|--|
| 117  | <b>Overplay Counter</b> - Displays the number of overplays selected since the last time the CLEAR PLAYS command (Selection 5 in the AUDITS menu) was used. The overplay counter is part of the CCC's memory, which keeps track of how many duplicate selections were made. A selection is considered to be a duplicate if it has been entered, but the CCC has not sent the selection number to the CD mechanism controller. |
| 118  | <b>My Song First Counter</b> - Displays the number of times the "My Song First" button was used to make a "My Song First" selection.   |
| 119  | <b>Not Used</b>  |
| 12   | <b>NON-RESETTABLES</b> - These totals for cash, plays, and credits can be displayed from any security level, but they cannot be reset from any security level. These totals constitute the permanent phonograph history.   |
| 120  | <b>Cash</b> - Displays total cash (bill and coin) received by the phonograph.  |
| 121  | <b>Bill</b> - Displays total bill cash received by the bill acceptor.  |
| 122  | <b>Coin</b> - Displays total coin cash received by the coin acceptor.  |
| 123  | <b>Wallbox</b> - Displays total cash received by all Wallboxes.  |
| 124  | <b>Free</b> - Displays total free credits.   |
| 125  | <b>Paid</b> - Displays total paid for credits.   |
| 126  | <b>Most Popular</b> - Displays the total number of Most Popular selections made with the POPULAR button.   |
| 127  | <b>Mechanism</b> - Displays the total number of mechanism cycles.  |
| 128  | <b>Album</b> - Display total album buys.   |
| 129  | <b>Selections</b> - Displays the total number of selections made using the keyboard.   |
| 2    | <b>ATTRACT</b> - This menu sets ATTRACT MODE ON or OFF and defines the ATTRACT MODE's characteristics.   |
| 20   | <b>Attract Mode</b> - Displays and toggles the ATTRACTMODE. Hold RESET while pushing 9 to toggle ON or OFF. Press POPULAR to save the change.  |

**Table 2-5A. Menu & Command Descriptions***Continued*

| Code | Description   |
|------|---|
| 21   | <b>Page Mode</b> - Displays and toggles the automatic page selection mode. Hold RESET while pushing 9 to toggle OFF, CHANGE, or AD. Press POPULAR to save the change. If OFF, the automatic page change selection is disabled. If CHANGE, a page will flip when the CHANGE TIME INTERVAL (22) elapses and the phonograph is in standby. If AD, the page mechanism will park at the DISPLAY PAGE (23) location when the CHANGE TIME INTERVAL elapses and the phonograph is in standby. |
| 22   | <b>Change Time</b> - Displays and sets the time interval for page changes (1 minute minimum) in minutes. Type in the new time in minutes then press POPULAR.  |
| 23   | <b>Display Page</b> - Page to be displayed in the AD mode. Type in the new page number then press POPULAR.  |
| 24   | <b>Title Page Number Control</b> - Controls the first and last page that can be selected from the keyboard. Type the low page number for IN then press POPULAR. Type the high page number for OUT then press POPULAR again.   |
| 25   | <b>Title Page Speed Control</b> - Controls the speed that the title pages will change. The IN value is the speed that the pages will turn when they are moving up, and the OUT value is the speed that the pages will turn when they are moving down. The allowable selections are 1-9. Type the new speed number for IN, then press POPULAR. Type the new speed number for OUT, then press POPULAR again.  |
| 26   | <b>Sled Reset</b> - Sets no. of plays done by the mech before a sled reset command is issued. Type # of plays & push POPULAR.   |
| 27   | <b>MESSAGE CENTER</b> - Is the menu that allows you to create and edit messages and alter the times and dates the messages are to appear.   |
| 28   | <b>Piezo Time</b> - Sets the time the buzzer will beep (in milliseconds). Enter the number and push POPULAR.  |
| 29   | <b>Play Delay</b> - Delay in seconds between the end of a selection and the beginning of the next. Range is 0, and 5 through 99 seconds (do not use numbers 1 through 4). This is a minimum time as it does not include the time to put the disc away if play delay is set to 5 or more seconds.  |
| 270  | <b>Msg Sch SMTWTFS</b> - Allows you to select the time, and days of the week the messages will be displayed. See <i>Programming the Rowe Message Center</i> .   |
| 271  | <b>1 ON 01 01 1980</b> - Allows you to display a message for one or several days. See <i>Programming the Rowe Message Center</i> .  |
| 272  | <b>Msg 1 Edt Del Vu</b> - Allows you to create, edit, or delete messages. See <i>Programming the Rowe Message Center</i> .  |

**Table 2-5A. Menu & Command Descriptions***Continued*

| Code           | Description   |
|----------------|---|
| <b>273</b>     | <b>Scroll Message</b> - Message editor for the 2nd scrolling line of a 2 line display. See <i>Programming the Rowe Message Center</i> . (Not used in this model phonograph.)  |
| <b>274</b>     | <b>4-Hour Clear</b> - Displays and toggles the 4-Hour Clear option ON or OFF. When 4-Hour Clear is ON, all selections remaining to be played will be cleared (if the phonograph is turned OFF for more than 4 consecutive hours, or the number of minutes entered by COMMAND 692). When this option is OFF, selections to be played will remain in the phonographs memory and they will play when the phonograph is turned back ON. Hold RESET and press 9 to toggle this option ON or OFF. Press POPULAR to save the change. |
| <b>275-276</b> | <b>Not Used</b>   |
| <b>277</b>     | <b>Discs Track Low Limit</b> - Allows you to view and change lower disc limits. The Track no. displayed is the lowest track no. that can be selected for that disc. To view disc lower limits, type the disc number. Press and hold RESET then press 3 (next disc) or 2 (previous disc) to view the next or previous disc lower limits. To change a discs lower limits, display the limits, then press POPULAR. Type the new limits, then press POPULAR.  |
| <b>278</b>     | <b>VIDEO CDS</b> - Set to JUK or ON to play video CD's. OFF for audio CD's. Press and hold RESET then press 9 to toggle between OFF, JUK, or ON. When setting to JUK, the video CD's must be entered in the Priority (61) buffer, and all discs not in the priority buffer are audio CD's. When setting to ON, all discs are video CD's. Press POPULAR to save your selection.  |
| <b>279</b>     | <b>Not Used</b>   |
| <b>3</b>       | <b>INITIALIZE</b> - This menu establishes the CD track numbers and saves them.  |
| <b>30</b>      | <b>Full Initialize</b> - Starts full mechanism initialization. Press POPULAR to select and note that the display will blink when this command is executed. All disc limits are set to 99, then as each disc is scanned, new limits are automatically entered into memory. Initialization begins when the SERVICE switch is moved to the NORMAL position. Full initialization takes about 30 minutes. During this time, selections can be played, but initialization will not continue until the phonograph is scanned out.    |
| <b>31</b>      | <b>Program Initialize</b> - Initializes specific discs automatically. Type the disc number to be initialized then press POPULAR. Type disc numbers until all disc numbers that need initializing have been entered. Initialization will begin when the service switch is moved back to the NORMAL position.   |
| <b>32</b>      | <b>Disc Initialize and Track Limits</b> - Allows you to view and change disc limits manually. To view disc limits, type the disc number. Press and hold RESET, then press 3 (next disc) or 2 (previous disc) to view the next or previous disc limits. To a change a discs limits, display the limits then press POPULAR. Type the new limits, then press POPULAR.  |

**Table 2-5A. Menu & Command Descriptions***Continued*

| Code     | Description  |
|----------|--|
| 33       | <b>Cancel Initialization</b> - Cancels initializations that have been started with either of the previous options (30 or 31). Press POPULAR to perform this function. The display will blink when the command is executed.   |
| 34       | <b>Initialized</b> - Displays the number of discs that have been initialized.  |
| 35       | <b>Number of Skips or Time Error Before Log</b> - Allows logging disc conditions without canceling selections. Type the new number, then press POPULAR. See <i>Disc Conditions</i> in <i>Section 5</i> for a detailed explanation of the Skip Log.   |
| 36       | <b>Skip Cancel</b> - Determines the maximum number of times that a CD may skip while playing before it is automatically canceled. Type the new number then press POPULAR. See <i>Disc Conditions</i> in <i>Section 5</i> for a detailed explanation of SKIP CANCEL.  |
| 37       | <b>Time Cancel</b> - The absolute time difference in seconds between current playing position (time position on the CD) and actual running time (phonograph time) before it is automatically canceled. Type the new number then press POPULAR. See <i>Disc Conditions</i> in <i>Section 5</i> for a detailed explanation of TIME CANCEL.   |
| 38       | <b>Time HH:MM:—</b> - Displays and sets the time-of-day. Hours and minutes can be entered, seconds will begin automatically at 00 (midnight) and count to 23:59, which is the 24-hour clock, or military time. Type the new hours and press POPULAR. Type the new minutes and then press POPULAR.  |
| Midnight | Is entered as 00:00. 12:59 PM (after noon) is the same, but:   |
| 1:00 PM  | Is entered as 13:00 and all the succeeding times are entered as 12+ the hour:  |
|          | 12:59 PM = 12:59      5:00 PM = 17:00      10:00 PM = 22:00  |
|          | 1:00 PM = 13:00      6:00 PM = 18:00      11:00 PM = 23:00   |
|          | 2:00 PM = 14:00      7:00 PM = 19:00      12:00 AM = 00:00   |
|          | 3:00 PM = 15:00      8:00 PM = 20:00      9:00 PM = 21:00  |
|          | 4:00 PM = 16:00  |
| 39       | <b>Date MM/DD/YYYY</b> - Displays and sets the date. Any date from the year 1980 to 2087 is allowed.   |
| 4        | <b>AUTOPLAY</b> - This menu sets AUTOPLAY ON or OFF and defines the Autoplay characteristics. If AUTOPLAY IS (COMMAND 40) has been set to STD, then COMMANDS 40 through 47 in this table apply. If AUTOPLAY IS (COMMAND 40) has been set to CDT, then COMMANDS 40 through 44 and COMMAND 47 in this table apply. If AUTOPLAY IS (COMMAND 40) has been set to ENH, then COMMANDS 40 through 49 apply and you should read about how to use these commands in the Enhanced Autoplay Tutorial that appears at the end of this section. |
| 40       | <b>Autoplay Is</b> - Displays and sets the AUTOPLAY style to either STANDARD, ENHANCED, CREDIT, or OFF. Press and hold RESET and then press 9 to toggle between the four options and press POPULAR to select the option that you want.   |

**Table 2-5A. Menu & Command Descriptions***Continued*

| Code     | Description  |
|----------|--|
| 41       | <b>Delay Time</b> - Displays and sets the time between Autoplay selections or displays and sets the time between giving a Credit. Type the number in minutes then press POPULAR. This command is used only in STANDARD and CREDIT Autoplay. Set TIMEDELAY to 00 for continuous Autoplay or Credit (as for background music).   |
| 42       | <b>Start Time</b> - Sets the time-of-day that Autoplay is allowed to begin making Autoplay selections or to begin to give Credits. Enter the time in 24-hour format (see the table that follows Stop Time). Type the hour then press POPULAR. Type the minute then press POPULAR. Both the hour and minute must be changed together.   |
| 43       | <b>Stop Time</b> - Sets the time of day that Autoplay will no longer be allowed to make selections or give credits. If you are not familiar with 24-hour time keeping, use the following table to help you figure the 24-hour time.  |
| Midnight | Is entered as 00:00. 12:59 PM (after noon) is the same, but:   |
| 1:00 PM  | Is entered as 13:00 and all the succeeding times are entered as 12+ the hour:  |
|          | 12:59 PM = 12:59      5:00 PM = 17:00      10:00 PM = 22:00  |
|          | 1:00 PM = 13:00      6:00 PM = 18:00      11:00 PM = 23:00   |
|          | 2:00 PM = 14:00      7:00 PM = 19:00      12:00 AM = 00:00   |
|          | 3:00 PM = 15:00      8:00 PM = 20:00      9:00 PM = 21:00  |
|          | 4:00 PM = 16:00  |
| 44       | <b>On Days SMTWTFS</b> - Allows you to select the days of the week that Autoplay can make selections or give credits. Press and hold RESET then press either 2 or 3 to move from day to day. The day currently selected will blink. Hold RESET and then press 9 to turn the day ON or OFF. Press POPULAR to save any changes.  |
| 45       | <b>Programmed</b> - Displays and changes the individual selection numbers that will be played. This mode allows you have Autoplay play specific selections or discs. A maximum of 100 selections or discs can be programmed. On the menu, the two-digit number is the play sequence number and the four-digit number is the selection number. If no programmed selections are made, the Autoplay function will select a random disc and a random track each time Autoplay makes a selection. If one or more selections are programmed, the programmed selections will be selected. A disc number followed by two zeros can be programmed. If you request disc 6300, for example, then Disc 63 will be programmed and a random track will be played from that disc (see <i>Programming Autoplay, Premiums, Priorities, Lockouts, and Pairs</i> ). |
| 46       | <b>Clear Programmed Mode</b> - Clears all programmed selections entered in COMMAND 45. Press POPULAR to perform this function. The display will blink when the command is executed.  |
| 47       | <b>Autoplay Status</b> - Allows you to change the AUTOPLAY STATUS immediately, without waiting for the START or STOP time of day. Hold RESET then press 9 to toggle the status ON or OFF. Press POPULAR to save the changes.   |

**Table 2-5A. Menu & Command Descriptions***Continued*

| Code | Description   |
|------|---|
| 48   | <b>XX Cat</b> - Assigns categories to discs in Enhanced Autoplay.   |
| 49   | <b>Schedule SMTWTFS</b> - The active days, time(s), categories, and delay(s) between Autoplay selections in Enhanced Autoplay.  |
| 5    | <b>PRICING</b> - This menu allows the operator to change CD pricing, coin switch values, credit levels, credit values, credit multiplier, Free Play value, and "My Song First" items.   |
| 50   | <b>COIN SWITCH VALUES</b> : - Is a menu that displays and sets various coin switch values.  |
| 51   | <b>PRICE LEVELS</b> : - Is a menu that displays various price levels.   |
| 52   | <b>PLAYS @ LEVEL</b> : - Is a menu that Displays and edits # of plays or alternate plays at a given level, and sets alternate price times.  |
| 53   | <b>Multiplier</b> - Displays and sets the coin multiplier value. For the U.S., this value is 5 (nickel). Type the new number then press POPULAR.  |
| 54   | <b>Timed Free Play</b> - Turns ON or turns OFF the timed free play schedule. Hold RESET then press 9 to toggle ON or OFF. Press POPULAR to save the change (see the Timed Free Play Example in this section).   |
| 55   | <b>Free Play Status</b> - Allows you to turn free play ON or OFF immediately without waiting for the start or stop time. Hold RESET then press 9 to toggle ON or OFF. Press POPULAR to save the change.   |
| 56   | <b>Short Pulses</b> - Set to ON if using electronic validation with multiple pulses per coin output. Hold RESET then press 9 to toggle ON or OFF. Press POPULAR to save your selection.   |
| 57   | <b>Not Used</b>   |
| 58   | <b>Free Sch SMTWTFS</b> - Allows you to select the days of the week and start and stop times for the Timed Free Play feature (see the Timed Free Play and Timed Lockout Scheduling Tutorial in this section).   |
| 59   | <b>Load Country Settings</b> - Loads the factory (default) settings for different countries. Hold RESET, then press 9 to toggle between United States (US), Australia (AUSTRALIA), United Kingdom (UK), and Canada (CANADA) pricing. The display will blink when the command is executed. |
| 50   | <b>COIN SWITCH VALUES</b> : - Displays and sets various coin switch values.   |
| 500  | <b>Not Used</b>   |
| 501  | <b>Coin SW1 = XX</b> - Displays and sets the #1 COIN SWITCH VALUE. Type the new value and then press POPULAR.   |

**Table 2-5A. Menu & Command Descriptions***Continued*

| Code    | Description  |
|---------|--|
| 502     | <b>Coin SW2 = XX</b> - Displays and sets the #2 COIN SWITCH VALUE. Type the new value and then press POPULAR.  |
| 503     | <b>Coin SW3 = XX</b> - Displays and sets the #3 COIN SWITCH VALUE. Type the new value and then press POPULAR.  |
| 504     | <b>Coin SW4 = XX</b> - Displays and sets the #4 COIN SWITCH VALUE. Type the new value and then press POPULAR.  |
| 505     | <b>Coin SW5 = XX</b> - Displays and sets the #5 COIN SWITCH VALUE. Type the new value and then press POPULAR.  |
| 506     | <b>Coin SW6 or Bill = XX</b> - Displays and sets the #6 COIN SWITCH VALUE or bill value that trips the #6 switch. Type the new value and then press POPULAR. |
| 507     | <b>Bill 1 = XX</b> - Displays and sets the #1 BILL VALUE. Type the new value and then press POPULAR.   |
| 508     | <b>Bill 2 = XX</b> - Displays and sets the #2 BILL VALUE. Type the new value and then press POPULAR.   |
| 509     | <b>Coin SW 6 or Bill Identifier</b> - Sets what type of input is seen on coin SW 6. Hold RESET and push key 9 to display choice, then push POPULAR.          |
| 51      | <b>PRICE LEVELS:</b> - Displays various price levels.  |
| 510     | <b>Not Used</b>  |
| 511     | <b>Level 1 Price = XX</b> - Displays and sets the price of the 1st credit level. Type the new value and then press POPULAR.                                  |
| 512     | <b>Level 2 Price = XX</b> - Displays and sets the price of the 2nd credit level. Type the new value and then press POPULAR.                                  |
| 513     | <b>Level 3 Price = XX</b> - Displays and sets the price of the 3rd credit level. Type the new value and then press POPULAR.                                  |
| 514     | <b>Level 4 Price = XX</b> - Displays and sets the price of the 4th credit level. Type the new value and then press POPULAR.                                  |
| 515     | <b>Level 5 Price = XX</b> - Displays and sets the price of the 5th credit level. Type the new value and then press POPULAR.                                  |
| 516-519 | <b>Not Used</b>  |



**Table 2-5A. Menu & Command Descriptions***Continued*

| Code | Description   |
|------|---|
| 52   | <b>PLAYS @ LEVEL:</b> - Displays and edits # of plays or alternate plays at a given level, and sets alternate price times.  |
| 520  | <b>Not Used</b>   |
| 521  | <b>Level 1 Plays = XX</b> - Displays and sets the number of plays given for this credit level. Type the new value and then press POPULAR. When setting, hold RESET and press 9 to select normal or alternate plays.   |
| 522  | <b>Level 2 Plays = XX</b> - Displays and sets the number of plays given for this credit level. Type the new value and then press POPULAR. When setting, hold RESET and press 9 to select normal or alternate plays.   |
| 523  | <b>Level 3 Plays = XX</b> - Displays and sets the number of plays given for this credit level. Type the new value and then press POPULAR. When setting, hold RESET and press 9 to select normal or alternate plays.   |
| 524  | <b>Level 4 Plays = XX</b> - Displays and sets the number of plays given for this credit level. Type the new value and then press POPULAR. When setting, hold RESET and press 9 to select normal or alternate plays.   |
| 525  | <b>Level 5 Plays = XX</b> - Displays and sets the number of plays given for this credit level. Type the new value and then press POPULAR. When setting, hold RESET and press 9 to select normal or alternate plays.   |
| 526  | <b>Alt Prc on hh:mm</b> - Displays and sets the time of day alternate pricing turns on. Enter the time in 24-hour format. Alternate pricing gives ALT 1 PLAYS XX, ALT 2 PLAYS XX, etc. instead of LVL 1 PLAYS XX, LVL 2 PLAYS XX, etc.  |
| 527  | <b>Alt Prc OFF hh:mm</b> - Displays and sets the time of day alternate pricing turns off. Set the OFF time equal to the ON time (CODE 526) if you do not want alternate pricing.  |
| 528  | <b>My Song First</b> - Allows you to turn the “My Song First” feature ON or OFF. Hold RESET and press 9 to toggle ON or OFF. Press POPULAR to save the change.  |
| 529  | <b>MSF Credits</b> - Displays and sets the number of credits required to make “My Song First”. Type the new value (1-5) and push POPULAR.   |
| 6    | <b>OPTIONS</b> - Displays and allows you to change the phonographs miscellaneous options.   |
| 60   | <b>Lockouts</b> - Displays and selects lockout selections or discs (50 maximum). These selections are not allowed to be selected by the customer or AUTOPLAY (see <i>Programming Autoplay, Premiums, Priorities, Lockouts, and Pairs</i> ). If a locked-out selection is attempted, the words Not Allowed will momentarily appear on the display. |
| 61   | <b>Priorities</b> - Displays and sets priority selections (100 maximum). When these selections are made by the customer, they will be inserted at the top of the play list and they will be played next (see <i>Programming Autoplay, Premiums, Priorities, Lockouts, and Pairs</i> ).  |

**Table 2-5A. Menu & Command Descriptions***Continued*

| Code | Description  |
|------|--|
| 62   | <b>Premiums</b> - Displays and sets premium selections. These selections (100 maximum) will be priced at 2 to 99 times the regular price (see <i>Programming Autoplay, Premiums, Priorities, Lockouts, Pairs, and Menu Code 6995</i> ).  |
| 63   | <b>Keep Credit</b> - Displays and toggles the KEEP CREDIT option ON or OFF to allow retaining or canceling credit upon Power up. Hold RESET and press 9 to toggle ON or OFF. Press POPULAR to save the changes.  |
| 64   | <b>Keep Money</b> - Displays and toggles the KEEP MONEY option ON or OFF to allow retaining or canceling money on power up. Hold RESET and press 9 to toggle ON or OFF. Press POPULAR to save the change.  |
| 65   | <b>Album Buy</b> - Displays and toggles the ALBUM BUY options ON or OFF so that entire albums can be selected. Albums can be selected from the phonograph and IR remote control if set to ON. Hold RESET and press 9 to toggle ON or OFF. Press POPULAR to save the change.  |
| 66   | <b>Priority Play</b> - Displays and toggles PRIORITY PLAY from ON to OFF. When PRIORITY PLAY is ON, priority plays will be allowed. When PRIORITY PLAY is OFF, this feature is disabled. Hold RESET and press 9 to toggle ON or OFF. Press POPULAR to save the change.   |
| 67   | <b>Tracks in a Row</b> - Displays and sets the maximum number of tracks <b>by the same artist</b> that can be played consecutively. Type the new number then press POPULAR.  |
| 68   | <b>Karaoke</b> - Displays and sets karaoke selections (100 maximum). When these selections are being played by the mech, the CCC will operate in the karaoke mode. The CCC sets an output bit to control the CD-G video decoder, and the CCC instructs the AMP that a karaoke selection is being played (see <i>Programming Autoplay, Premiums, Priorities, Lockouts, and Pairs</i> ). |
| 69   | <b>MORE OPTIONS 1</b> - The MORE OPTIONS 1 menu is a continuation of the OPTIONS menu.   |
| 690  | <b>Paid Play</b> - Determines the play sequence for paid selections. This option toggles between random (RAND) and FIFO (First In First Out) sequences. Hold RESET and press 9 to toggle RAND or FIFO. Press POPULAR to save the change.   |
| 691  | <b>Free Play</b> - Determines the play sequence for free selections. This option toggles between random (RAND) and FIFO (First In First Out) sequences. Hold RESET and press 9 to toggle RAND or FIFO. Press POPULAR to save the change.   |
| 692  | <b>Clear Time</b> - Allows values from 00 to 999 minutes for the 4-HOUR CLEAR (274) TIME. The factory setting is 240 minutes. Type the new number, then press POPULAR.   |

**Table 2-5A. Menu & Command Descriptions***Continued*

| Code        | Description   |
|-------------|---|
| <b>693</b>  | <b>Lockout Count</b> - Adds the selection to the LOCKOUT LIST (60) when the DISC CONDITIONS NUMBER OF SKIP OCCURRENCES reaches the programmed value. To change the LOCKOUT COUNT, type the new number and then press POPULAR.   |
| <b>694</b>  | <b>Play Limit</b> - Sets a maximum time for a selection to play before it is canceled. A 0 entry disables this feature. Valid times are from 60 to 999 seconds. If the optional volume control module is installed, the volume of the selection will fade before the selection is canceled.   |
| <b>695</b>  | <b>Cancel Autoplay</b> - Cancels the autoplay selection when a paid selection is entered. When this feature is turned ON, the Autoplay selection will cancel within 15 seconds and the paid selection will play next. When this feature is turned OFF, the Autoplay selection will finish playing before the paid selection plays. The default for this feature is ON.  |
| <b>696</b>  | <b>Autoplay Only</b> - Stores the disc numbers for up to 25 discs. These disc numbers can be selected by Autoplay, but they cannot be selected by customers (see <i>Programming Autoplays, Premiums, Priorities, Lockouts, and Pairs</i> ).   |
| <b>697</b>  | <b>Daylight Savings Time</b> - Automatically adjusts daylight saving time. STD moves the clock ahead one hour at 2:00 AM on the first Sunday of April. This mode will also move the clock back one hour at 2:00 AM on the last Sunday of October. NONSTD lets you select which months and days of the month that daylight savings will be turned ON and OFF. Hold RESET and press 9 to select STD, NONSTD, or OFF. Press POPULAR to save your choice. If you select NONSTD, the display shows DAYLIT ON --/--. Type two digits for the month code to turn daylight savings ON and then press POPULAR. Type the two-digit day number (1 through 31). Note that the CCC will only accept the correct maximum number. Then press POPULAR. Hold RESET and press 9 to change the display to show: DAYLIT OFF --/--. Type two digits for the month code to turn daylight savings OFF and then press POPULAR. Type the two-digit day number (1 through 31). Note that the CCC will only accept the correct maximum number. Then press POPULAR. |
| <b>698</b>  | <b>Automat Clr</b> - Clears audit data. If this command is set to ON, and the AUDIT START button has been used to start the report, then the audit data will be cleared when the printing stops and the phonograph is in NORMAL mode. Hold RESET and press 9 to toggle this command ON and OFF. Press POPULAR to save your choice.  |
| <b>699</b>  | <b>MORE OPTIONS 2</b> - This menu is a continuation of the OPTIONS menu.  |
| <b>6990</b> | <b>Timlock</b> - Displays and sets timed lockout selections or discs (25 maximum). See <i>Programming Autoplay, Premiums, Priorities, Lockouts, and Pairs</i> .   |
| <b>6991</b> | <b>LockSch SMTWTFs</b> - Allows you to select the days of the week and the start and stop times for timed lockouts. (See the Timed Free Play and Timed Lockouts Scheduling Tutorial.)   |

**Table 2-5A. Menu & Command Descriptions***Continued*

| Code | Description   |
|------|---|
| 6992 | <b>Free Album</b> - Allows entire albums to be selected if FREE PLAY (55) and ALBUMBUY (65) are ON. Hold RESET and press 9 to toggle this command ON and OFF. Press POPULAR to save your choice.  |
| 6993 | <b>Thank You On/Off</b> - If set to ON, the “Thank You” message is briefly displayed when a customer completes his final selection (the credit goes to zero). Hold RESET and press 9 to toggle this command ON and OFF. Press POPULAR to save your choice.  |
| 6994 | <b>Popular Key ON/OFF</b> - If set to ON, most POPULAR selections are allowed using the POPULAR key. If set to off, most popular selections are not allowed. Hold RESET and press 9 to toggle ON and OFF.   |
| 6995 | <b>Premium Ratio</b> - Displays and sets the number of credits needed to make a premium selection (see CODE 62).  |
| 6996 | <b>Autolod Dflt</b> - Displays and toggles the autolod default option. Factory default settings will load automatically if a RAM checksum error occurs and this option is ON. Set this option to OFF if you do not want factory settings loaded automatically.  |
| 6997 | <b>RAM Test Code</b> - Displays status of the RAM. <b>0</b> indicates that the RAM test passed, <b>1</b> indicates a disc limit error, <b>2</b> indicates a PREMIUM, LOCKOUT, or PRIORITY LIST error, and <b>3</b> indicates a pricing or other error.  |
| 6998 | <b>Sel xxxx hh:mm</b> - Displays and sets time of day for a specific selection to play. Type in selection number, then press POPULAR. To remove selection, hold RESET and push 9. Type in the hour, and press POPULAR. Type in the minutes, and press POPULAR.  |
| 6999 | <b>Pairs Sel</b> — - Displays and sets paired selections (10 maximum). Paired selections are a short teaser and the following selection, or a selection and the following short trailer. If either of the pair is selected, the other is selected automatically for free. When programming, enter first selection of pair (i.e., teaser, if teaser and selection; or selection, if selection and trailer). See <i>Programming Autoplay, Premiums, Priorities, Lockouts, and Pairs</i> . |
| 7    | <b>REPORTS</b> - The REPORTS menu provides an output to an RS-232 serial printer or computer with an RS-232 serial interface. To use this feature, the RS-232 Option must be installed in the phonograph. To select and print the report, type the code for the report and press POPULAR. The display will blink when the command is executed.  |
| 70   | <b>Cash Report</b> - Starts the Cash Report.  |
| 71   | <b>Play Report</b> - Starts the Play Report.  |
| 72   | <b>Popular Report</b> - Starts a Popularity Report.   |
| 73   | <b>Non-Resettable Report</b> - Starts the report of all non-resettable numbers.   |

**Table 2-5A. Menu & Command Descriptions***Continued*

| Code | Description  |
|------|--|
| 74   | <b>All Audit Report</b> - Starts all 4 audit reports.  |
| 75   | <b>Setup Report</b> - Starts the phonograph Setup Report.  |
| 76   | <b>Error History Report</b> - Starts the Accumulated Phonograph Errors Report.   |
| 77   | <b>Disc Condition Report</b> - Starts the Disc Condition Report.   |
| 78   | <b>Baud Rate</b> - Selects either 600, 1200, 2400, 4800, or 9600 baud for printing reports. Hold RESET and press 9 to toggle between 600, 1200, 2400, 4800, and 9600 baud. Press POPULAR to save the change. Also, Spec Report is used to eliminate spaces from the report. Type 0001, then press POPULAR to eliminate spaces. To retain spaces, type 0000, then press POPULAR. A carriage return delay (CRMS Delay) is available to interface with slower printers. |
| 79   | <b>Cancel Reports</b> - Stops all report printing.   |
| 8    | <b>STATUS</b> - The STATUS menu defines credit and displays figures, which indicate the condition of the phonograph.   |
| 80   | <b>Error History</b> - Displays the error history of the phonograph (see <i>Errors and Warnings</i> in <i>Section 5</i> ).   |
| 81   | <b>Clear Errors</b> - Clears all errors from the phonographs error log. Press POPULAR to perform this function. The display will blink when this command is executed.  |
| 82   | <b>Clear Credits</b> - Clears all current credit. Press POPULAR to perform this function. The display will blink when this command is executed.  |
| 83   | <b>Clear Selections</b> - Clears all selections remaining to be played. Press POPULAR to perform this function. The display will blink when this command is executed.  |
| 84   | <b>CREDITS</b> - Displays and changes the number of credits. Type the number of credits then press POPULAR.  |
| 85   | <b>Selections Left</b> - Displays the current number of selections left to be played.  |
| 86   | <b>Disc Conditions</b> - Displays the condition of discs played (see <i>Disc Conditions</i> in <i>Section 5</i> ).   |
| 87   | <b>Clear Conditions</b> - Clears the current conditions from the phonograph. Press POPULAR to perform this function. The display will blink when this command is executed.   |
| 88   | <b>Display Software Versions</b> - Displays the current version number of phonograph modules. Hold RESET and press 3 to view the next device version number.   |

**Table 2-5A. Menu & Command Descriptions***Continued*

| Code | Description  |
|------|--|
| 89   | <b>ON/OFF Cycles</b> - Displays and changes the number of ON/OFF cycles.   |
| 9    | <b>DEVICE SETUP</b> - The DEVICE SETUP menu activates and defines the AMPLIFIER, VOLUME CONTROL, and IR REMOTE options.  |
| 90   | <b>AMPLIFIER</b> - The AMPLIFIER menu activates and defines the AMPLIFIER options. (4-channel preamplifier only)   |
| 91   | <b>IR REMOTE</b> - The IR REMOTE menu activates and defines IR REMOTE options.   |
| 92   | <b>Main Display Line</b> - Sets which display line is used for the scrolling line, and which is used for the main display. Hold RESET and push 9 to select, and then push POPULAR.   |
| 93   | <b>BGM Delay Time</b> - Time in seconds to delay BGM mode after the phono goes into standby mode. The range is <b>1</b> to <b>99</b> seconds. This is a minimum time as it does not include the time to put the disc away if BGM delay time is set longer than 2 seconds. Type the number of seconds and push POPULAR.   |
| 94   | <b>Lead Singer</b> - Sets the Karaoke Lead Singer on <b>LEFT</b> or <b>RIGHT</b> channel. Hold RESET and push 9 to select, and then push POPULAR. (4-channel preamplifier only)  |
| 95   | <b>Amp Factory Load</b> - Loads factory settings for the AMP. (4-channel preamplifier only)  |
| 96   | <b>Autoplay/BGM Volume</b> - Displays and sets autoplay volume to <b>OFF</b> , <b>SEPART</b> , or <b>LOCKED</b> . Hold RESET and press 9 to toggle between <b>OFF</b> , <b>SEPARATE</b> , AND <b>LOCKED</b> . Push POPULAR to save your choice. <b>OFF</b> means there is 1 adjustable volume for BGM, Autoplay, and paid play (if playing ENH autoplay sel with REL VOL set, only the volume for that selection will be different by the REL VOL amount). <b>SEPARATE</b> means there is one adjustable volume for BGM and Autoplay (if playing ENH autoplay sel with REL VOL set, only the volume for that selection will be different by the REL VOL amount), and another for paid play. <b>LOCKED</b> means there is one locked volume for BGM and autoplay (if playing ENH autoplay sel with REL VOL set, only the volume for that selection will be different by the REL VOL amount), and another adjustable volume for paid play. To set the locked level, make a selection, wait until it starts playing. Use IR remote to set the volume you like for autoplay. Then go to the SERVICE mode. Type 96. Hold RESET and toggle 9 until display shows AP VOLUME LOCKED, then press POPULAR. |
|      | (4-channel preamplifier only)  |
| 97   | <b>Volume Option</b> - This sets the way the volume control up/down buttons affect the volumes of the 4 different AMP volume channels (for master volume control - not for MIC volume control).  |
| 1    | means any of CH1 or CH2 volume up/down switches will adjust AMP CH1 and CH2 volumes (those 2 AMP volumes are locked together). Any of CH3 or CH4 switches will adjust AMP CH3 and CH4 volumes (those 2 AMP volumes are locked together).   |
| 2    | means CH4 volume up/down switch controls AMP CH4 volume. Any of CH1, CH2, or CH3 switches will adjust AMP CH1, CH2, and CH3 volumes (those 3-amp volumes are locked together).   |

**Table 2-5A. Menu & Command Descriptions***Continued*

| Code | Description  |
|------|--|
| 3    | means CH3 volume up/down switch controls AMP CH3 volume. Any of CH1, CH2, or CH4 switches will adjust AMP CH1, CH2, and CH4 volumes (those 3-amp volumes are locked together).   |
| 4    | means CH2 volume up/down switch controls AMP CH2 volume. Any of CH1, CH3, or CH4 switches will adjust AMP CH1, CH3, and CH4 volumes (those 3-amp volumes are locked together).   |
| 5    | means CH1 volume up/down switch controls AMP CH1 volume. Any of CH2, CH3, or CH4 switches will adjust AMP CH2, CH3, and CH4 volumes (those 3-amp volumes are locked together).   |
| 6    | means CH3 or CH4 volume up/down switches controls AMP CH3 or CH4 volumes respectively. Any of CH1 or CH2 switches will adjust AMP CH1 and CH2 volumes (those 2-amp volumes are locked together).   |
| 7    | means CH1 or CH2 volume up/down switches controls AMP CH1 or CH2 volumes respectively. Any of CH3 or CH4 switches will adjust AMP CH3 and CH4 volumes (those 2-amp volumes are locked together).   |
| 8    | means CH1, CH2, CH3, or CH4 volume up/down switches controls AMP CH1, CH2, CH3, or CH4 volumes respectively.   |
| 9    | means any of CH1 or CH3 volume up/down switches will adjust AMP CH1 and CH3 volumes (those 2 AMP volumes are locked together). Any of CH2 or CH4 switches will adjust AMP CH2 and CH4 volumes (those 2 AMP volumes are locked together). |
| 10   | or higher means any of CH1, CH2, CH3, or CH4 volume up/down switch will adjust AMP CH1, CH2, CH3, and CH4 volumes (those 4 AMP volumes are locked together). Type in the value and push POPULAR.   |
|      | (4-channel preamplifier only)  |
| 98   | <b>IR Volume Step</b> - Sets the amount of volume change each IR volume key up/down produces. The range is 1-5 steps. Type in the value and push POPULAR. (4-channel preamplifier only)  |
| 99   | <b>Not Used</b>  |
| 90   | <b>AMPLIFIER</b> - Activates and defines the AMPLIFIER options.  |
| 900  | <b>Mic Volume Override Ch 1</b> - Adjusts the main volume for CH 1 of the music/BGM input source when a paging MIC is keyed. The range is 0-63. Type in the volume you want and push POPULAR.  |
| 901  | <b>Mic Volume Override Ch 2</b> - Adjusts the main volume for CH 2 of the music/BGM input source when a paging MIC is keyed. The range is 0-63. Type in the volume you want and push POPULAR.  |
| 902  | <b>Mic Volume Override Ch 3</b> - Adjusts the main volume for CH 3 of the music/BGM input source when a paging MIC is keyed. The range is 0-63. Type in the volume you want and push POPULAR.  |
| 903  | <b>Mic Volume Override Ch 4</b> - Adjusts the main volume for CH 4 of the music/BGM input source when a paging MIC is keyed. The range is 0-63. Type in the volume you want and push POPULAR.  |

**Table 2-5A. Menu & Command Descriptions***Continued*

| Code | Description  |
|------|--|
| 904  | <b>Mic 1 Routing</b> - Sets MIC 1 to route to any or all of the 6 different PREAMP output channels (left to right: AUXR, AUXL, CH1, CH2, CH3, CH4). If <b>0</b> on the display for the channel, the MIC will not route to that channel. If <b>1</b> , then the MIC routes to the channel. Push and hold RESET, then press either 2 or 3 to step thru the channels.   |
| 905  | <b>Mic 2 Routing</b> - Sets MIC 2 to route to any or all of the 6 different PREAMP output channels (left to right: AUXR, AUXL, CH1, CH2, CH3, CH4). The channel currently selected will blink. Hold RESET and press 9 to select <b>0</b> (do not route) or <b>1</b> (route). Then push POPULAR.  |
| 906  | <b>Mic 3 Routing</b> - Sets MIC 3 to route to any or all of the 6 different PREAMP output channels (left to right: AUXR, AUXL, CH1, CH2, CH3, CH4). The channel currently selected will blink. Hold RESET and press 9 to select <b>0</b> (do not route) or <b>1</b> (route). Then push POPULAR.  |
| 907  | <b>Mic Type</b> - Sets the type of MIC to either karaoke or paging. The same MIC can be used for either type. The amp uses this to be able to control the volume of the main (music/BGM) source for each type. Also, the leftmost bit (bit 5) is the configuration bit. <b>0</b> = CD100K and <b>1</b> = Download. Bit 2, 1, 0 is MIC 3, 2, 1 respectively. <b>0</b> = karaoke and <b>1</b> = page. Hold RESET and push 2 or 3 to select MIC. Hold RESET and push 9 to select MIC type, and push POPULAR |
| 908  | <b>BGM VOLUME MAX</b> - Sets the maximum volume level that BGM volume may be set to. The range is <b>0-63</b> . Type in volume and push POPULAR.   |
| 909  | <b>MORE AMP 1</b> - This menu is a continuation of the AMPLIFIER menu  |
| 9090 | <b>CD Input Preset Volume Level</b> - Sets the CD input level from <b>0-50</b> . Type in new level and push POPULAR.   |
| 9091 | <b>Stereo A Input Preset Volume Level</b> - Sets the stereo a input level from <b>0-50</b> . Type in new level and push POPULAR.   |
| 9092 | <b>Stereo B Input Preset Volume Level</b> - Sets the stereo b input level from <b>0-50</b> . Type in new level and push POPULAR.   |
| 9093 | <b>Mono Input Preset Volume Level</b> - Sets the mono input level from <b>0-50</b> . Type in new level and push POPULAR.   |
| 9094 | <b>Channel 1&amp;2 Output Preset Volume Level</b> - Sets the CH 1&2 output level from <b>0-50</b> . Type in new level and push POPULAR.  |
| 9095 | <b>Channel 3&amp;4 Output Preset Volume Level</b> - Sets the CH 3&4 output level from <b>0-50</b> . Type in new level and push POPULAR.  |



**Table 2-5A. Menu & Command Descriptions***Continued*

| Code  | Description   |
|-------|---|
| 9096  | <p><b>Equalizer Ch 1,2</b> - Sets the Ch 1&amp;2 5-band Equalizers. The range is <b>0-9</b> (left to right: <b>CH1</b> - 59hz, 205hz, 790hz, 2.95khz, 12khz; <b>CH2</b> - 59hz, 205hz, 790hz, 2.95khz, 12khz)<br/> <b>0</b> = maximum attenuation for particular frequency.<br/> <b>9</b> = minimum attenuation for particular frequency.<br/>           Hold RESET and push 2 or 3 to select channel frequency. Push key 0 – 9 to select attenuation at the channel frequency and push POPULAR.</p>  |
| 9097  | <p><b>Equalizer Ch 3,4</b> - Sets the Ch 3&amp;4 5-band Equalizers. The range is <b>0-9</b> (left to right: <b>CH3</b> - 59hz, 205hz, 790hz, 2.95khz, 12khz); <b>CH4</b> - 59hz, 205hz, 790hz, 2.95khz, 12khz)<br/> <b>0</b> = maximum attenuation for particular frequency.<br/> <b>9</b> = minimum attenuation for particular frequency.<br/>           Hold RESET and push 2 or 3 to select channel frequency. Push key 0 – 9 to select attenuation at the channel frequency and push POPULAR.</p> |
| 9098  | <b>Not Used</b>   |
| 9099  | <b>MORE AMP 2</b> - This menu is a continuation of the AMPLIFIER menu.  |
| 90990 | <p><b>Playing Audio Input Select</b> - Sets the input to the preamp when playing an audio selection. Set for one of following: (Mono C = <b>1</b>, Stereo B = <b>3</b>, Stereo A = <b>4</b>, CD player = <b>5</b>). Type in 1, 3, 4, or 5 and push POPULAR.</p>   |
| 90991 | <p><b>Playing Karaoke Input Select</b> - Sets the input to the preamp when playing a Karaoke selection. Set for one of following: (Mono C = <b>1</b>, Stereo B = <b>3</b>, Stereo A = <b>4</b>, CD player = <b>5</b>). Type in 1, 3, 4, or 5 and push POPULAR.</p>  |
| 90992 | <p><b>Playing Video Input Select</b> - Sets the input to the preamp when playing a Video selection. Set for one of following: (Mono C = <b>1</b>, Stereo B = <b>3</b>, Stereo A = <b>4</b>, CD player = <b>5</b>). Type in 1, 3, 4, or 5 and push POPULAR.</p>  |
| 90993 | <p><b>Standby Input Select</b> - Sets the input to the preamp when standby. Set for one of following: (Mono C = <b>1</b>, Stereo B = <b>3</b>, Stereo A = <b>4</b>, CD player = <b>5</b>). Type in 1, 3, 4, or 5 and push POPULAR.</p>  |
| 90994 | <p><b>BGM Input Select</b> - Sets the input to the preamp when BGM. Set for one of following: (Mono C = <b>1</b>, Stereo B = <b>3</b>, Stereo A = <b>4</b>, CD player = <b>5</b>). Type in 1, 3, 4 or 5 and push POPULAR.</p>   |
| 90995 | <p><b>Mic Input Select</b> - Sets the input to the preamp when MIC is keyed. Set for one of following: (Mono C = <b>1</b>, Stereo B = <b>3</b>, Stereo A = <b>4</b>, CD player = <b>5</b>, input unchanged = <b>6</b>). Type in 1, 3, 4, 5, or 6 and push POPULAR.</p>  |

**Table 2-5A. Menu & Command Descriptions***Continued*

| Code   | Description   |
|--------|---|
| 90996  | <b>Playing Audio Muting</b> - Sets the muting to the amp when playing an audio selection. Set any or all of the 8 different amp mute devices (left to right: AUDIO/VIDEO CONTROLLER OUT CH3&4, AUDIO/VIDEO CONTROLLER OUT CH1&2, FRONT END INPUT, AVC, POWER AMP OUT CH4, POWER AMP OUT CH3, POWER AMP OUT CH2, POWER AMP OUT CH1). <b>0</b> = Mute that channel. <b>1</b> = Unmute that channel. Duplicate the 2 <sup>nd</sup> part of MIC 1 routing starting with push and hold RESET.    |
| 90997  | <b>Playing Karaoke Muting</b> - Sets the muting to the AMP when playing a Karaoke selection. Set any or all of the 8 different AMP mute devices (left to right: AUDIO/VIDEO CONTROLLER OUT CH3&4, AUDIO/VIDEO CONTROLLER OUT CH1&2, FRONT END INPUT, AVC, POWER AMP OUT CH4, POWER AMP OUT CH3, POWER AMP OUT CH2, POWER AMP OUT CH1). <b>0</b> = Mute that channel. <b>1</b> = Unmute that channel. Duplicate the 2 <sup>nd</sup> part of MIC 1 routing starting with push and hold RESET. |
| 90998  | <b>Playing Video Muting</b> - Sets the muting to the AMP when playing a Video selection. Set any or all of the 8 different AMP mute devices (left to right: AUDIO/VIDEO CONTROLLER OUT CH3&4, AUDIO/VIDEO CONTROLLER OUT CH1&2, FRONT END INPUT, AVC, POWER AMP OUT CH4, POWER AMP OUT CH3, POWER AMP OUT CH2, POWER AMP OUT CH1). <b>0</b> = Mute that channel. <b>1</b> = Unmute that channel. Duplicate the 2 <sup>nd</sup> part of MIC 1 routing starting with push and hold RESET.     |
| 90999  | <b>MORE AMP 3</b> - This menu is a continuation of the AMPLIFIER menu.  |
| 909990 | <b>Standby Muting</b> - Sets the muting to the amp when standby. Set any or all of the 8 different AMP mute devices (left to right: AUDIO/VIDEO CONTROLLER OUT CH3&4, AUDIO/VIDEO CONTROLLER OUT CH1&2, FRONT END INPUT, AVC, POWER AMP OUT CH4, POWER AMP OUT CH3, POWER AMP OUT CH2, POWER AMP OUT CH1). <b>0</b> = Mute that channel. <b>1</b> = Unmute that channel. Duplicate the 2 <sup>nd</sup> part of MIC 1 routing starting with push and hold RESET.                             |
| 909991 | <b>BGM Muting</b> - Sets the muting to the amp when BGM. Set any or all of the 8 different AMP mute devices (left to right: AUDIO/VIDEO CONTROLLER OUT CH3&4, AUDIO/VIDEO CONTROLLER OUT CH1&2, FRONT END INPUT, AVC, POWER AMP OUT CH4, POWER AMP OUT CH3, POWER AMP OUT CH2, POWER AMP OUT CH1). <b>0</b> = Mute that channel. <b>1</b> = Unmute that channel. Duplicate 2 <sup>nd</sup> part of MIC 1 routing starting with push and hold RESET.   |
| 909992 | <b>Mic Muting</b> - Sets the muting to the amp when MIC is keyed. Set any or all of the 8 different AMP mute devices (left to right: AUDIO/VIDEO CONTROLLER OUT CH3&4, AUDIO/VIDEO CONTROLLER OUT CH1&2, FRONT END INPUT, AVC, POWER AMP OUT CH4, POWER AMP OUT CH3, POWER AMP OUT CH2, POWER AMP OUT CH1). <b>0</b> = Mute that channel. <b>1</b> = Unmute that channel. Duplicate the 2 <sup>nd</sup> part of MIC 1 routing starting with push and hold RESET.                            |

**Table 2-5A. Menu & Command Descriptions***Continued*

| Code    | Description   |
|---------|---|
| 909993  | <b>Playing Audio Output Select Ch 1,2</b> - Sets the output select for channel pairs 1&2 of the amp when playing audio. Set for one of following: (mono/mono = <b>1</b> , aux/aux = <b>2</b> , mono/aux = <b>3</b> , aux/mono = <b>4</b> , stereo/stereo = <b>5</b> ). Type in 1, 2, 3, 4, or 5 and push POPULAR.     |
| 909994  | <b>Playing Audio Output Select Ch 3,4</b> - Sets the output select for channel pairs 3&4 of the amp when playing audio. Set for one of following: (mono/mono = <b>1</b> , aux/aux = <b>2</b> , mono/aux = <b>3</b> , aux/mono = <b>4</b> , stereo/stereo = <b>5</b> ). Type in 1, 2, 3, 4, or 5 and push POPULAR.     |
| 909995  | <b>Playing Karaoke Output Select Ch 1,2</b> - Sets the output select for channel pairs 1&2 of the amp when playing Karaoke. Set for one of following: (mono/mono = <b>1</b> , aux/aux = <b>2</b> , mono/aux = <b>3</b> , aux/mono = <b>4</b> , stereo/stereo = <b>5</b> ). Type in 1, 2, 3, 4, or 5 and push POPULAR. |
| 909996  | <b>Playing Karaoke Output Select Ch 3,4</b> - Sets the output select for channel pairs 3&4 of the amp when playing Karaoke. Set for one of following: (mono/mono = <b>1</b> , aux/aux = <b>2</b> , mono/aux = <b>3</b> , aux/mono = <b>4</b> , stereo/stereo = <b>5</b> ). Type in 1, 2, 3, 4, or 5 and push POPULAR. |
| 909997  | <b>Playing Video Output Select Ch 1,2</b> - Sets the output select for channel pairs 1&2 of the amp when playing Video. Set for one of following: (mono/mono = <b>1</b> , aux/aux = <b>2</b> , mono/aux = <b>3</b> , aux/mono = <b>4</b> , stereo/stereo = <b>5</b> ). Type in 1, 2, 3, 4, or 5 and push POPULAR.     |
| 909998  | <b>Playing Video Output Select Ch 3,4</b> - Sets the output select for channel pairs 3&4 of the amp when playing Video. Set for one of following: (mono/mono = <b>1</b> , aux/aux = <b>2</b> , mono/aux = <b>3</b> , aux/mono = <b>4</b> , stereo/stereo = <b>5</b> ). Type in 1, 2, 3, 4, or 5 and push POPULAR.     |
| 909999  | <b>MORE AMP 4</b> - This menu is a continuation of the AMPLIFIER menu.  |
| 9099990 | <b>Standby Output Select Ch 1,2</b> - Sets the output select for channel pairs 1&2 of the amp when standby. Set for one of following: (mono/mono = <b>1</b> , aux/aux = <b>2</b> , mono/aux = <b>3</b> , aux/mono = <b>4</b> , stereo/stereo = <b>5</b> ). Type in 1, 2, 3, 4 or 5 and push POPULAR.                  |
| 9099991 | <b>Standby Output Select Ch 3,4</b> - Sets the output select for channel pairs 3&4 of the amp when standby. Set for one of following: (mono/mono = <b>1</b> , aux/aux = <b>2</b> , mono/aux = <b>3</b> , aux/mono = <b>4</b> , stereo/stereo = <b>5</b> ). Type in 1, 2, 3, 4 or 5 and push POPULAR.                  |
| 9099992 | <b>BGM Output Select Ch 1,2</b> - Sets the output select for channel pairs 1&2 of the amp when BGM. Set for one of following: (mono/mono = <b>1</b> , aux/aux = <b>2</b> , mono/aux = <b>3</b> , aux/mono = <b>4</b> , stereo/stereo = <b>5</b> ). Type in 1, 2, 3, 4 or 5 and push POPULAR.                          |
| 9099993 | <b>BGM Output Select Ch 3,4</b> - Sets the output select for channel pairs 3&4 of the amp when BGM. Set for one of following: (mono/mono = <b>1</b> , aux/aux = <b>2</b> , mono/aux = <b>3</b> , aux/mono = <b>4</b> , stereo/stereo = <b>5</b> ). Type in 1, 2, 3, 4 or 5 and push POPULAR.                          |



**Table 2-5A. Menu & Command Descriptions***Continued*

| Code | Description   |
|------|---|
| 911  | <b>Remote Selections</b> - Displays and sets remote selections to ON, OFF, ICD, or XCD. If this command is set to ON, you can always use the IR remote control to make a selection or give a credit. If this command is set to OFF, remote control selections and credits are not allowed at all. If this command is set to ICD, remote control selections and credits are allowed as long as REMOTE CREDIT (92) exceeds zero. If set to XCD, remote control selections are allowed when remote credit (92) or external credit (selections remaining on digital display) exceeds zero, and remote control credits are allowed when remote credit (see 92) exceeds zero. Hold RESET and push 9 to select ON, OFF, ICD or XCD. Press POPULAR to save. |
| 912  | <b>Remote Credit</b> - Displays and changes the number of internal remote credits. If RMT SELECT (91) is set to ICD or XCD, remote credit decrements each time you use the IR remote control to make a selection or give a credit. Type the number of credits, then press POPULAR.  |
| 913  | <b>Remote Pause</b> - Allows the remote to pause the phonograph if this feature is set to ON. Hold RESET and press 9 to toggle this command ON and OFF. Press POPULAR to save your choice.  |
| 914  | <b>Remote Pause Time</b> - Displays and sets the number of minutes the phonograph can be paused. Type the new number, then press POPULAR to save your choice.   |
| 915  | <b>Remote Autoplay Override</b> - Allows the remote to turn Autoplay either ON or OFF if this feature is ON. Hold RESET and press 9 to toggle ON and OFF. Press POPULAR to save your choice.  |
| 916  | <b>Remote Reload</b> - Once a week (on Monday) the value in this location is added to the REMOTE CREDIT (MENU COMMAND 92). Type the number of credits you want to give each week. Press POPULAR to save your choice.  |
| 917  | <b>Remote Input Select</b> - Allows the Remote to command the Preamp to switch to the next input (Stereo A, Stereo B, Mono C, CD Player) if this feature is on. Hold RESET and press 9 to toggle ON or OFF. Then press POPULAR. (4-channel preamplifier only)   |
| 918  | <b>IR Clear Sel</b> - <b>OFF</b> means don't allow the IR remote to clear all selections. <b>ON</b> means allow the IR remote to clear all selections.  |
| 919  | <b>Remote Plays</b> - Displays the number of selections made from the remote.   |

Table 2-5B. CD-100K Command Index

| Function                                 | Menu         | Command         |
|--|--------------|-----------------|
| <b>Album</b>                             |              |                 |
| free - on/off                            | OPTIONS      | 6992            |
| maximum tracks in a row                  | OPTIONS      | 67              |
| Select - on/off                          | OPTIONS      | 65              |
| <b>Amplifier (4-channel preamp only)</b> |              |                 |
| autoplay/bgm volume                      | DEVICE SETUP | 96              |
| bgm delay time                           | DEVICE SETUP | 93              |
| bgm volume maximum                       | AMPLIFIER    | 908             |
| equalizer settings                       | AMPLIFIER    | 9096-9097       |
| input select for each mode               | AMPLIFIER    | 90990-90995     |
| input volume preset levels               | AMPLIFIER    | 9090-9093       |
| ir volume step                           | DEVICE SETUP | 98              |
| karaoke lead singer channel              | DEVICE SETUP | 94              |
| load amplifier factory settings          | DEVICE SETUP | 95              |
| main volume override when mic keyed      | AMPLIFIER    | 900-903         |
| microphone routing                       | AMPLIFIER    | 904-906         |
| microphone type paging/karaoke           | AMPLIFIER    | 907             |
| muting/unmuting for each mode            | AMPLIFIER    | 90996-909992    |
| output select for each mode              | AMPLIFIER    | 909993-9099995  |
| output volume preset levels              | AMPLIFIER    | 9094-9095       |
| volume control mask for switches         | AMPLIFIER    | 9099996-909999  |
| volume option setting                    | DEVICE SETUP | 97              |
| <b>Attract mode</b>                      |              |                 |
| change time between page changes         | ATTRACT      | 22              |
| select a specific AD page                | ATTRACT      | 23              |
| set speed that title pages turn          | ATTRACT      | 25              |
| set title page number limits             | ATTRACT      | 24              |
| turn attract on/off                      | ATTRACT      | 20              |
| turn auto page change on/off             | ATTRACT      | 21              |
| <b>Audits</b>                            |              |                 |
| all audit                                | REPORTS      | 74              |
| automatic clear                          | OPTIONS      | 698             |
| cash                                     | AUDITS       | 100-109,118,119 |
| non-resettable                           | AUDITS       | 120-129         |
| play                                     | AUDITS       | 110-117         |

**Table 2-5B. CD-100K Command Index***Continued*

| <b>Function</b>                        | <b>Menu</b>  | <b>Command</b> |
|--|--------------|----------------|
| <b>Autoplay</b>                        |              |                |
| autoplay/bgm volume                    | DEVICE SETUP | 96             |
| autoplay days of the week enable       | AUTOPLAY     | 44             |
| autoplay only discs                    | OPTIONS      | 696            |
| autoplay start time                    | AUTOPLAY     | 42             |
| autoplay status on/off                 | AUTOPLAY     | 47             |
| autoplay stop time                     | AUTOPLAY     | 43             |
| cancel autoplay select early on/off    | OPTIONS      | 695            |
| clear programmed Autoplay              | AUTOPLAY     | 46             |
| enhanced categories                    | AUTOPLAY     | 48             |
| enhanced schedules                     | AUTOPLAY     | 49             |
| select a specific disc and track       | AUTOPLAY     | 45             |
| time between Autoplays                 | AUTOPLAY     | 41             |
| turn Autoplay on/off                   | AUTOPLAY     | 40             |
| <b>Cash</b>                            |              |                |
| clear                                  | AUDITS       | 14             |
| keep credit after power failure on/off | OPTIONS      | 63             |
| keep money after power failure on/off  | OPTIONS      | 64             |
| multiplier                             | PRICING      | 53             |
| report                                 | REPORTS      | 70             |
| <b>Clear</b>                           |              |                |
| cash                                   | AUDITS       | 14             |
| conditions                             | STATUS       | 87             |
| credits                                | STATUS       | 82             |
| disc popularity                        | AUDITS       | 13             |
| errors                                 | STATUS       | 81             |
| plays                                  | AUDITS       | 15             |
| programmed autoplay selections         | AUTOPLAY     | 46             |
| selection popularity                   | AUDITS       | 16             |
| selections                             | STATUS       | 83             |
| <b>Coin and Bill</b>                   |              |                |
| Bill values                            | PRICING      | 506-509        |
| Coin switch short pulses               | PRICING      | 56             |
| Coin switch values                     | PRICING      | 501-506,509    |

**Table 2-5B. CD-100K Command Index***Continued*

| <b>Function</b>                          | <b>Menu</b>  | <b>Command</b> |
|--|--------------|----------------|
| <b>Credit</b>                            |              |                |
| autoplay                                 | AUTOPLAY     | 40-44, 47      |
| clear credits                            | STATUS       | 82             |
| display or change credits                | STATUS       | 84             |
| free play - on/off                       | PRICING      | 55             |
| keep credit after power failure on/off   | OPTIONS      | 63             |
| levels                                   | PRICING      | 511-515        |
| multiplier                               | PRICING      | 53             |
| “my song first”                          | PRICING      | 528-529        |
| remaining                                | STATUS       | 84             |
| selections remaining                     | STATUS       | 85             |
| values                                   | PRICING      | 521-527        |
| <b>Daylight saving time settings</b>     |              |                |
| date and time change                     | INITIALIZE   | 39 and 38      |
| saving time OFF/STD/NONSTD               | OPTIONS      | 697            |
| saving time OFF date (non standard only) | OPTIONS      | 697            |
| saving time ON date (non standard only)  | OPTIONS      | 697            |
| <b>Defaults</b>                          |              |                |
| default all - automatic                  | OPTIONS      | 6996           |
| default amplifier settings               | DEVICE SETUP | 95             |
| default factory load test code           | OPTIONS      | 6997           |
| default pricing                          | PRICING      | 59             |
| <b>Disc</b>                              |              |                |
| autoplay                                 | AUTOPLAY     | 40-49          |
| clear conditions                         | STATUS       | 87             |
| conditions                               | STATUS       | 86             |
| conditions report                        | REPORTS      | 77             |
| initialize                               | INITIALIZE   | 30-33          |
| lockout count                            | OPTIONS      | 693            |
| play delay                               | ATTRACT      | 29             |
| play limit                               | OPTIONS      | 694            |
| play selection at programmable time      | OPTIONS      | 998            |
| <b>Errors</b>                            |              |                |
| clear                                    | STATUS       | 81             |
| history                                  |              |                |



**Table 2-5B. CD-100K Command Index***Continued*

| <b>Function</b>                    | <b>Menu</b>    | <b>Command</b> |
|------------------------------------|----------------|----------------|
| <b>Factory loads</b>               |                |                |
| factory load all - automatic       | OPTIONS        | 6996           |
| factory load amplifier settings    | DEVICE SETUP   | 95             |
| factory load pricing               | PRICING        | 59             |
| factory load test code             | OPTIONS        | 6997           |
| <b>Free play</b>                   |                |                |
| album                              | OPTIONS        | 6992           |
| on days                            | PRICING        | 58             |
| start time                         | PRICING        | 58             |
| status on/off                      | PRICING        | 55             |
| stop time                          | PRICING        | 58             |
| timed on/off                       | PRICING        | 54             |
| <b>Initialize</b>                  |                |                |
| all discs (takes 30 minutes)       | INITIALIZE     | 30             |
| by disc number                     | INITIALIZE     | 31             |
| cancel auto initialize             | INITIALIZE     | 33             |
| condition log                      | INITIALIZE     | 35             |
| number of discs initialized        | INITIALIZE     | 34             |
| set track limit for a disc         | INITIALIZE     | 32,277         |
| skip count                         | INITIALIZE     | 36             |
| skip time (delay before cancel)    | INITIALIZE     | 37             |
| <b>Karaoke</b>                     |                |                |
| Karaoke lead singer channel        | DEVICE SETUP   | 94             |
| Karaoke selections                 | OPTIONS        | 68             |
| <b>Lockouts</b>                    |                |                |
| lockout (do not allow) a selection | OPTIONS        | 60             |
| on days                            | OPTIONS        | 6991           |
| start time                         | OPTIONS        | 6991           |
| stop time                          | OPTIONS        | 6991           |
| timed                              | OPTIONS        | 6990           |
| <b>Messages</b>                    |                |                |
| message daily scheduler            | MESSAGE CENTER | 270            |
| message date scheduler             | MESSAGE CENTER | 271            |
| message editor                     | MESSAGE CENTER | 272            |
| scroll message editor              | MESSAGE CENTER | 273            |

**Table 2-5B. CD-100K Command Index***Continued*

| <b>Function</b>                           | <b>Menu</b> | <b>Command</b> |
|---|-------------|----------------|
| <b>Modem</b>                              |             |                |
| answer off time                           | MODEM       | 082            |
| answer on time                            | MODEM       | 081            |
| connect delay                             | MODEM       | 085            |
| # of post/page retries                    | MODEM       | 0895           |
| # of rings to answer on                   | MODEM       | 083            |
| page (send errors to a pager) on/off      | MODEM       | 0896           |
| page to post (send errors to a PC) on/off | MODEM       | 0897           |
| pager suffix                              | MODEM       | 0899           |
| pager telephone number                    | MODEM       | 0898           |
| password                                  | MODEM       | 080            |
| post days active                          | MODEM       | 0891           |
| post off time                             | MODEM       | 0893           |
| post on time                              | MODEM       | 0892           |
| post reports to a PC on/off               | MODEM       | 0890           |
| post telephone number                     | MODEM       | 0894           |
| receive enable                            | MODEM       | 084            |
| receive initialize string                 | MODEM       | 087            |
| restore factory values                    | MODEM       | 088            |
| transmit initialize string                | MODEM       | 086            |
| <b>Money</b>                              |             |                |
| clear                                     | AUDITS      | 14             |
| keep on/off                               | OPTIONS     | 64             |
| <b>Plays</b>                              |             |                |
| audit                                     | PLAY AUDITS | 110-117        |
| clear                                     | AUDITS      | 15             |
| free play style (sequential or random)    | OPTIONS     | 691            |
| paid play style (sequential or random)    | OPTIONS     | 690            |
| paired selections                         | OPTIONS     | 6999           |
| <b>Phonograph commands</b>                |             |                |
| clear selections after phono              |             |                |
| OFF 4-hours (on/off)                      | ATTRACT     | 274            |
| clear sels after 4-hours OFF time         | OPTIONS     | 692            |
| clear credit                              | STATUS      | 82             |
| clear errors                              | STATUS      | 81             |
| display credit                            | STATUS      | 84             |
| # of power on/off cycles                  | STATUS      | 89             |
| phono ID change                           | SECURITY    | 04             |
| selections remaining                      | STATUS      | 85             |

**Table 2-5B. CD-100K Command Index***Continued*

| <b>Function</b>                 | <b>Menu</b>  | <b>Command</b> |
|---------------------------------|--------------|----------------|
| <b>Popularity</b>               |              |                |
| clear disc pop                  | AUDITS       | 13             |
| clear sel pop                   | AUDITS       | 16             |
| disk                            | AUDITS       | 17,18          |
| least popular discs             | AUDITS       | 18             |
| most popular discs              | AUDITS       | 17             |
| most popular selections         | AUDITS       | 19             |
| report                          | REPORTS      | 72             |
| <b>Pricing</b>                  |              |                |
| bill values                     | PRICING      | 506-509        |
| buy an album - on/off           | OPTIONS      | 65             |
| coin switch values              | PRICING      | 501-506,509    |
| multiplier                      | PRICING      | 53             |
| “my song first”                 | PRICING      | 528-529        |
| plays at price level            | PRICING      | 521-527        |
| premium plays (special pricing) | OPTIONS      | 62, 6995       |
| price levels                    | PRICING      | 511-515        |
| use factory (default) pricing   | PRICING      | 59             |
| <b>Priorities</b>               |              |                |
| enable priority plays on/off    | OPTIONS      | 66             |
| maximum tracks to play in a row | OPTIONS      | 67             |
| play a specific selection       | OPTIONS      | 61             |
| <b>Remote</b>                   |              |                |
| autoplay override on/off        | REMOTE       | 915            |
| autoplay volume                 | DEVICE SETUP | 96             |
| clear all sels on/off           | REMOTE       | 918            |
| credits                         | REMOTE       | 912            |
| input select key on/off         | REMOTE       | 917            |
| maximum pause time              | REMOTE       | 914            |
| pause on/off                    | REMOTE       | 913            |
| plays                           | REMOTE       | 919            |
| reload credits                  | REMOTE       | 916            |
| selections on/off               | REMOTE       | 911            |
| volume step                     | DEVICE SETUP | 98             |

**Table 2-5B. CD-100K Command Index***Continued*

| <b>Function</b>                     | <b>Menu</b>    | <b>Command</b> |
|-------------------------------------|----------------|----------------|
| <b>Reports</b>                      |                |                |
| all audit                           | REPORTS        | 74             |
| baud rate                           | REPORTS        | 78             |
| cancel                              | REPORTS        | 79             |
| carriage return delay               | REPORTS        | 78             |
| cash                                | REPORTS        | 70             |
| disc conditions                     | REPORTS        | 77             |
| eliminate/retain spaces in report   | REPORTS        | 78             |
| error history                       | REPORTS        | 76             |
| non resettables                     | REPORTS        | 73             |
| play                                | REPORTS        | 71             |
| popular                             | REPORTS        | 72             |
| set up                              | REPORTS        | 75             |
| <b>Security</b>                     |                |                |
| change level 2                      | SECURITY       | 02             |
| change level 3                      | SECURITY       | 03             |
| enter security code                 | SECURITY       | 00             |
| level display                       | SECURITY       | 01             |
| phono ID                            | SECURITY       | 04             |
| security is on/off                  | SECURITY       | 06             |
| <b>Miscellaneous</b>                |                |                |
| mechanism player sled reset         | ATTRACT        | 26             |
| piezo buzzer active time            | ATTRACT        | 28             |
| popular key on/off                  | OPTIONS        | 6994           |
| program with top door closed on/off | SECURITY       | 05             |
| service switch enable - on/off      | SECURITY       | 05             |
| software level                      | STATUS         | 88             |
| “thank you” message on/off          | OPTIONS        | 6993           |
| time and date change                | INITIALIZE     | 38 and 39      |
| tracks in a row                     | OPTIONS        | 67             |
| versions                            | STATUS         | 88             |
| video CD's                          | MESSAGE CENTER | 278            |
| volume control mask for switches    | AMPLIFIER      | 9099996-909999 |
| volume option setting               | DEVICE SETUP   | 97             |

**Table 2-5B. CD-100K Command Index***Continued*

| <b>Function</b>            | <b>Menu</b> | <b>Command</b> |
|----------------------------|-------------|----------------|
| Software level             | STATUS      | 88             |
| “Thank You” message on/off | OPTIONS     | 6993           |
| Time and date change       | INITIALIZE  | 38 and 39      |
| Tracks in a row            | OPTIONS     | 67             |
| Versions                   | STATUS      | 88             |

## **PROGRAMMING AUTOPLAY, PREMIUMS, PRIORITIES, LOCKOUTS, AND PAIRS**

Each of these seven options will allow programming specific selection or disc numbers into memory. The procedure is the same for all seven options.

Place the phonograph into the SERVICE mode and get to the \*SERVICE MODE\* display (hold RESET and press POPULAR as many times as necessary to display \*SERVICE MODE\*). Enter the command for the particular option to be programmed.

### **For Autoplay Programming**

#### **Type Display shows**

- 4 \*AUTOPLAY\*
- 5 PROGRAM 00 ----

### **For Autoplay Only Programming**

#### **Type Display shows**

- 69 \* MORE OPTIONS 1 \*
- 6 AP ONLY 00 ----

### **For Lockouts Programming**

#### **Type Display shows**

- 6 \*OPTIONS\*
- 0 LOCKOUTS 00----

### **For Timed Lockout Programming**

#### **Type Display shows**

- 699 \* MORE OPTIONS 2 \*
- 0 TIM LOCK 00 ----

**For Priorities Programming**

| Type | Display Shows    |
|------|------------------|
| 6    | *OPTIONS*        |
| 1    | PRIORITY 00 ---- |

**For Premiums Programming**

| Type | Display Shows    |
|------|------------------|
| 6    | *OPTIONS*        |
| 2    | PREMIUMS 00 ---- |

**For Pairs Programming**

| Type | Display Shows     |
|------|-------------------|
| 699  | *MORE OPTIONS 2*  |
| 9    | PAIRS SEL 00 ---- |

If a selection is not programmed for the displayed sequence number, four dashes will appear. When first received from the factory, none of these options will have any selections programmed. It is possible to program up to 100 autoplay selections or discs, 25 Autoplay only discs, 25 premium selections, 50 lockout selections, 10 priority selections, and 10 paired selections. The program sequence number will start at 00 and go to 1 less than the maximum possible programmed selections. For example, the sequence numbers for lockouts will start at 00 and go to 49.

All selections must be in consecutive sequence locations. You may not have a “hole” in the sequence. For example, premium 00 is programmed to Selection 1305. The next premium selection must be entered in sequence location 01. The phonograph will not allow a hole to be left in the sequence.

**AUTOPLAY PROGRAMMING MODES**

When the Autoplay program sequence does not have any selections in it, Autoplay will select a random disk and track to play whenever the Autoplay time has elapsed. By entering selections into the sequence program, Autoplay will follow that sequence and play only those selections entered. The order of play will follow the sequence.

When entering a selection number ending in 00 (this is not normally a valid selection) in to the Autoplay sequence, Autoplay will select a random selection from that particular disk. For example, sequence number 04 has Selection 5200 programmed in. When Autoplay gets to sequence number 04 (the 5th Autoplay selection to be played), it will play a random track from disk 52.

Specific selection numbers and random selections on specific disks may be entered together and in any order in an Autoplay sequenced program.

## LOCKOUT AND TIMED LOCKOUT MODES

To lockout a disc, enter the two-digit disc number followed by two zeros. To lockout a selection, enter the four-digit selection number.

If you are at Security Level 3 and have one of the four programming options on the display, you will notice the 1's digit of the sequence number will be blinking. The blinking digit indicates it may be changed. Type the sequence number where the new selection is to be entered then push POPULAR. If the sequence number entered would create a hole, the display will change to show the next available sequence number. The 1's digit in the selection number will now blink. Type in a four-digit selection number (two-digit disc number for Autoplay only), then press POPULAR to save it. The 1's digit in the sequence number will now blink, allowing another sequence number to be entered.

If you try to enter a selection from a disk that has limits of 0 (the disk is not installed in the machine or it has not yet been initialized), the four dashes will reappear when POPULAR is pushed.

By holding RESET and pushing 3, the next sequence number and selection will be displayed. Holding RESET and pushing 2 will display the previous sequence number.

## EDITING AUTOPLAY, PREMIUMS, PRIORITIES AND LOCKOUTS

To change a selection number, use RESET + 2 and RESET + 3 to scan the sequence looking for the selection to be changed. If the sequence number of the selection to be changed is known, simply type the sequence number. When the proper selection is displayed, push POPULAR to move the blinking digit to the 1's position of the selection number. Type in the new four-digit selection number (a two-digit disc number for Autoplay only) then push POPULAR. If you try to enter a selection from a disk that has limits of 0 (the disk is not installed or not yet initialized), the original selection will be automatically reinserted when POPULAR is pushed.

To delete a selection number, locate that selection as described above. Push and hold RESET, then push 4 once. The selection will be deleted. The next selection will be moved down into this sequence number to fill the hole the deletion would have left.

To add a selection in the middle of a list, locate the selection previous to selection you want to enter. Hold RESET and push 5 once. This will open a hole in the list. Type the new selection number then push POPULAR. If you try to enter a selection from a disk that has limits of 0 (the disk is not installed in the machine or it has not yet been initialized), selection 0001 will be inserted automatically.

## TIMED FREE PLAY AND TIMED LOCKOUT SCHEDULING TUTORIAL

### What Multiple Lockout On/Off Times Do

Multiple lockout On/Off times allow you to lockout (prevent selecting or playing) specific selections or discs up to three times a day each day of the week. Selections or discs to be locked-out are entered in OPTION 6990 (TIMLOCK). Scheduling and entering the times is done in the same manner as MULTIPLE FREEPLAY ON/OFF times (*refer to the Timed Free Play example*).

### What Multiple Freeplay On/Off Times Do

Multiple Freeplay ON/OFF Times allow you to stimulate interest in the phonograph by offering free plays at up to three times a day each day of the week. Note that this feature only schedules the Freeplay times. To allow Freeplay, you must be sure to turn the TIMED FPLAY (COMMAND 54) ON before Freeplay will be enabled.



See *Table 2-5A* for Commands 54, 55, and 58.

If FREE PLAY STATUS is ON, the phonograph will be on Free Play. If FREE PLAY STATUS is OFF, the phonograph will not be on FREE PLAY.

Free Play status will always be turned OFF when a STOP time and day matches the time and day on the "Real-Time Clock" and timed Free Play is set to ON.

Free Play status will only turn ON when the START time and day matches the time and day of the "Real-Time Clock" and timed Free Play is set to ON.

When timed Free Play is set to OFF, the system will not turn Free Play status ON or OFF.

## 1. Turn Timed Freeplay On

**Example:** The example shown in *Figure 2-11* shows the Multiple Freeplay On/Off Times sheet filled out for Sunday and Monday. To make keying the schedule easier, use this form to make your plans, then key in the schedule (Photocopy the original of this form, which is in the back of this section.)

| <b>MULTIPLE FREEPLAY ON/OFF TIMES</b>  |           |            |                             |
|--|-----------|------------|-----------------------------|
| Fill in the START times, STOP times, and the COMMENTS before you make the actual scheduling changes. |           |            |                             |
| <b>Sunday</b>  | <b>On</b> | <b>Off</b> | <b>Comment</b>              |
| 1  | 10 : 00   | 10 : 30    | One Freeplay Period _____   |
| 2  | __ : __   | __ : __    | _____                       |
| 3  | __ : __   | __ : __    | _____                       |
| <b>Monday</b>  | <b>On</b> | <b>Off</b> | <b>Comment</b>              |
| 1  | 11 : 15   | 11 : 30    | Two Freeplay Periods _____  |
| 2  | 14 : 30   | 14 : 45    | _____                       |
| 3  | __ : __   | __ : __    | _____                       |
| <b>Tuesday</b>   | <b>On</b> | <b>Off</b> | <b>Comment</b>              |
| 1  | __ : __   | __ : __    | No Freeplay Scheduled _____ |
| 2  | __ : __   | __ : __    | _____                       |
| 3  | __ : __   | __ : __    | _____                       |

**Figure 2-11. Sample Freeplay Schedule**



## 2. Plan the Schedule

Scheduling Freeplay is simple, just remember these rules:

### SCHEDULING RULES

The schedule must have one ON time and a corresponding OFF time for each scheduled time. These times must follow these simple restrictions:

#### Examples:

|        |       |       |  |
|--------|-------|-------|--|
| Monday | ON    | OFF   | <b>Wrong</b> - The OFF time is set before the ON time.<br>The ON time must be earlier than the corresponding OFF time. |
| 1      | 10:30 | 10:00 |  |

|        |       |       |   |
|--------|-------|-------|---|
| Monday | ON    | OFF   | <b>Wrong</b> - A gap was left in the schedule.<br>Gaps are not allowed. |
| 1      | 10:00 | --:-- |   |
| 2      | 11:00 | 11:30 |   |

|        |       |       |  |
|--------|-------|-------|--|
| Monday | ON    | OFF   | <b>Wrong</b> - No OFF time was scheduled.<br>Each scheduled Freeplay time must have<br>an ON time and an OFF time. |
| 1      | 15:00 | --:-- |  |
| 2      | --:-- | --:-- |  |

|        |       |       |   |
|--------|-------|-------|---|
| Monday | ON    | OFF   | <b>Right</b> - The proper times were entered and<br>the schedule is complete. |
| 1      | 10:00 | 10:30 |   |
| 2      | 11:00 | 11:30 |   |

## 3. Enter the Schedule

If you have not verified that Timed Freeplay is ON, go back to the previous topics and check the Freeplay status before you make or change the Freeplay Schedule.

- A. From the \*SERVICE MODE\* display, enter 58 to display Line 8 of the Pricing Menu. This line will show: FREE SCH SMTWTFs with the first "S" (Sunday) in the calendar blinking<sup>1</sup>.
- B. Move the cursor to another day by pressing either RESET + 2 or by pressing RESET + 3.
- C. Move the cursor back to Monday and press POPULAR to view Monday's schedule.
- D. At this time the display shows MON-1 ON --:-- and the 1's digit of the hours field is blinking<sup>2</sup>. The MON-1 on the display indicates that this schedule entry is the first Monday ON time. Enter the first Monday ON time hour from the sample schedule (see Figure 2-11) by entering the ON time hour and then pressing POPULAR. Enter the minutes in the same way, and then press POPULAR.
- E. To move to the first OFF time for Monday, press RESET + 3, enter the OFF time, and press POPULAR.
- F. Press RESET + 3 to advance to second OFF time. Enter OFF Time and then press POPULAR.
- G. Press RESET + 9 to move back to the FREE SCH display.

<sup>1</sup> Any blinking letter or number represents the "cursor", which is the pointer that indicates what information will be changed if you make an entry.

<sup>2</sup> A field is a space to enter or display numbers or letters.

## 4. Copy the Schedule

Now to program the phonograph for the rest of the week. You can copy the schedule you just made into any/all of the remaining days of the week. To make the schedule for Tuesday through Friday the same as Monday:

- A. Move the cursor until the M for Monday is blinking.
- B. Press RESET + 8 and the display will show: CPY MO -> S
- C. Press RESET + 2 and RESET + 3 until MTWTF appears on the display. MTWTF on the display indicates that Monday's schedule will be copied into the Monday through Friday schedules.
- D. Press POPULAR to perform the copy.

## ROWE PHONOGRAPH MESSAGE CENTER

The **Rowe Message Center** allows you to program messages to play for any desired date and time. Up to eight different messages may be used, with three programmable ON/OFF times for each day of the week.

### Getting into message program menu:

1. Pull the SERVICE switch out to the SERVICE position. The display shows SERVICE MODE.
2. By entering 27 on the keyboard the display advances to the MESSAGE CENTER.

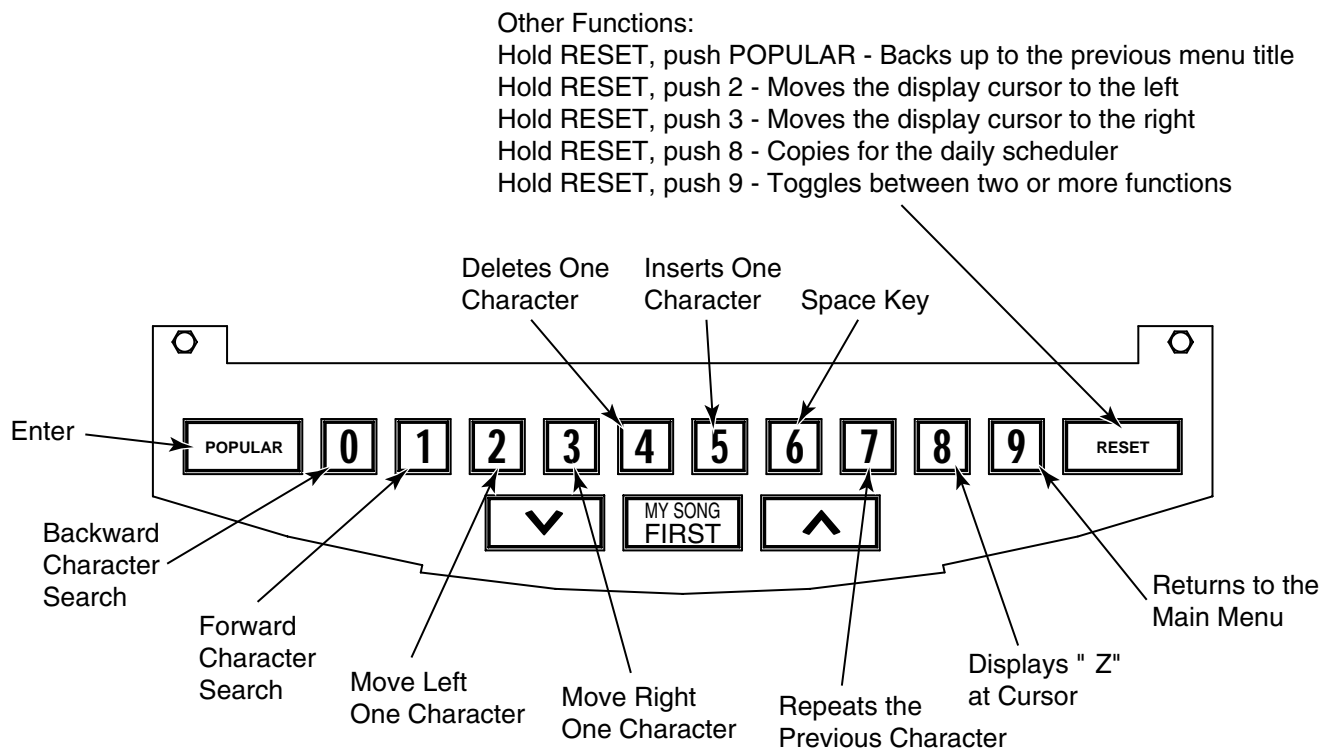

**Message Programming Keys**

## Selecting Characters

The following is a list of available characters in order of appearance in the message programming menu. Note that the cursor begins at a "space" and can be moved either left (by pushing key 0) to the number 9, or right (by pushing the 1 key) to the letter A. (If key 8 is pushed, the cursor begins at letter Z.)

[ \ ] \_ @ ; ( = ) ? ! " # \$ % & ' < > \* + - /

0 1 2 3 4 5 6 7 8 9 space A through Z

### Character Map



### NOTE:

Before pushing the keys shown in sections AA, BB, or CC, the display must show **MESSAGE CENTER**. If it doesn't, hold **RESET** and repeatedly push the **POPULAR** key until the display shows **SERVICE MODE**. Enter 27. **MESSAGE CENTER** is now being displayed. Also, if you make a mistake or have a problem in a menu, use this procedure to start over.

### Note #1.

## AA. Inserting or Changing Messages: Push 2 (see Note #1)

When the desired item is flashing, push **POPULAR** to execute. Hold **RESET** and repeatedly push 3 to select item.

1. The display screen reads MSG 1 EDT DEL VU.
  - MSG 1- Selects a message (from number 1-8) to edit.
  - EDT- Allows you to enter or change the selected message.
  - DEL- Deletes the selected message from memory. (You must push **POPULAR** three times to delete a message.)
  - VU- Displays the selected message.

## Example for programming a new message

When this example is complete, the display will read HELLO TOM as message number three.

- A. Follow step **AA** to obtain MSG 1 EDT DEL VU.
- B. Push key 3 to edit message three. Push POPULAR.
- C. Push POPULAR to go to the edit screen.
- D. Display should be blank except the cursor flashing at digit eight (*see Table 2-6*).
- E. Push key 1 until the display shows H. Push POPULAR (cursor points to the next character).
- F. Push key 1 until the display shows E. Push POPULAR.
- G. Push key 1 until display shows L. Press POPULAR.
- H. Push key 7. Display shows L. Press POPULAR.
- I. Push key 7. Display shows L. Then push key 1 until the display shows O. Press POPULAR.
- J. Push POPULAR. Display shows a “space”.
- K. Push key 1 until display shows T. Push POPULAR.
- L. Push key 7. Display shows T. Then push key 0 until display shows O. Push POPULAR.
- M. Push key 7. Display shows O. Then push key 0 until display shows M. Push POPULAR.
- N. Press the key 9 to exit and save the message.

**Table 2-6. Example Message Program Sequence Display**

|   | 1 | 2 | 3 | 4 | 5 | 6 | 7 | 8 | 9 | 10 | 11 | 12 | 13 | 14 | 15 | 16 |
|---|---|---|---|---|---|---|---|---|---|----|----|----|----|----|----|----|
| A | M | S | G |   | 1 |   | E | D | T |    | D  | E  | L  |    | V  | U  |
| B | M | S | G |   | 3 |   | E | D | T |    | D  | E  | L  |    | V  | U  |
| C |   |   |   |   |   |   |   | — |   |    |    |    |    |    |    |    |
| D |   |   |   |   |   |   | H | — |   |    |    |    |    |    |    |    |
| E |   |   |   |   |   | H | E | — |   |    |    |    |    |    |    |    |
| F |   |   |   |   | H | E | L | — |   |    |    |    |    |    |    |    |
| G |   |   |   | H | E | L | L | — |   |    |    |    |    |    |    |    |
| H |   |   | H | E | L | L | O | — |   |    |    |    |    |    |    |    |
| I |   | H | E | L | L | O |   | — |   |    |    |    |    |    |    |    |
| J | H | E | L | L | O |   | T | — |   |    |    |    |    |    |    |    |
| K | E | L | L | O |   | T | O | — |   |    |    |    |    |    |    |    |
| L | L | L | O |   | T | O | M | — |   |    |    |    |    |    |    |    |
| M | M | S | G |   | 3 |   | E | D | T |    | D  | E  | L  |    | V  | U  |

## Example for correcting or editing an existing message

When the example is complete, the display will read TOPS IN MUSICLAND for message 6. Previously, this message displayed TOYS FOR TOTS. Note - all editing keys will be used to show their effect on the message.

- A. Follow step **AA** to obtain the display MSG 1 EDT DEL VU (*see Table 2-7*).
- B. Press 6 to edit message 6. Push POPULAR.
- C. Push POPULAR to go to the edit screen.  
Display characters 1-7 are blank. Character 8 is a flashing T. Characters 9-16 are characters OYS FOR.
- D. Push key 3 twice. The Y should be flashing. Push key 0 until the flashing digit is a P. Push POPULAR.
- E. Push key 3 twice. The F should be flashing. Push key 1 until the digit is an I. Push POPULAR.
- F. The O is flashing. Push key 0 once. The digit is an N. Push POPULAR.
- G. The R is flashing. Push key 6. The digit is now a "space." Push POPULAR.
- H. The cursor is flashing. Push key 1 until M is displayed. Push POPULAR.
- I. The T is flashing. Push key 1 once. The digit is now a U. Push POPULAR.
- J. The O is flashing. Push key 5. The display shows a space inserted between the U and 0. Push key 1 until the digit is an S. Push POPULAR.
- K. The O is flashing. Push the 0 until the digit is an I. Press POPULAR.
- L. The T is flashing. Push key 4. The display shows that the T was removed. Push key 1 until the C is displayed. Push POPULAR.
- M. Push key 1 until the L is displayed. Push POPULAR
- N. Push key 1 until the A is displayed. Push POPULAR
- O. Push key 1 until the N is displayed. Push POPULAR
- P. Push key 1 until the D is displayed. Push POPULAR
- Q. Push key 9 to exit and save the message.

Table 2-7. Example Message Edit Display

|    | 1 | 2 | 3 | 4 | 5 | 6 | 7 | 8 | 9 | 10 | 11 | 12 | 13 | 14 | 15 | 16 |
|----|---|---|---|---|---|---|---|---|---|----|----|----|----|----|----|----|
| A  | M | S | G |   | 1 |   | D | E | L |    | E  | D  | T  |    | V  | U  |
| B  | M | S | G |   | 6 |   | E | D | T |    | D  | E  | L  |    | V  | U  |
| C  |   |   |   |   |   |   |   |   | O | Y  | S  |    | F  | O  | R  |    |
| D  |   |   |   |   | T | O | P | S |   | F  | O  | R  |    | T  | O  | T  |
| E  |   | T | O | P | S |   | I | O | R |    | T  | O  | T  | S  |    |    |
| F  | T | O | P | S |   | I | N | R |   | T  | O  | T  | S  |    |    |    |
| G  | O | P | S |   | I | N |   | — | T | O  | T  | S  |    |    |    |    |
| H  | P | S |   | I | N |   | M | T | O | T  | S  |    |    |    |    |    |
| I  | S |   | I | N |   | M | U | O | T | S  |    |    |    |    |    |    |
| J1 | S |   | I | N |   | M | U | — | O | T  | S  |    |    |    |    |    |
| J2 |   | I | N |   | M | U | S | O | T | S  |    |    |    |    |    |    |
| K  | I | N |   | M | U | S | I | T | S |    |    |    |    |    |    |    |
| L1 | I | N |   | M | U | S | I | S |   |    |    |    |    |    |    |    |
| L2 | N |   | M | U | S | I | C | — |   |    |    |    |    |    |    |    |
| M  |   | M | U | S | I | C | L | — |   |    |    |    |    |    |    |    |
| N  | M | U | S | I | C | L | A | — |   |    |    |    |    |    |    |    |
| O  | U | S | I | C | L | A | N | — |   |    |    |    |    |    |    |    |
| P  | S | I | C | L | A | N | D | — |   |    |    |    |    |    |    |    |
| Q  | M | S | G |   | 6 |   | E | D | T |    | D  | E  | L  |    | V  | U  |

**BB. Setting the daily message display time(s): Push 0 (see NOTE #1 on Page 2-56)**

When you initially program a message, you must activate the daily message display timer for that message. This section discusses how to program messages to play at any given time of day for the week.

There are three available ON/OFF time settings for each day. There are also ON/OFF settings for each day of the week.

The display screen reads MSG SCH SMTWTFS.

- MSG SCH means that you are in the MESSAGE SCHEDULE MENU. This menu allows daily message plays.
- SMTWTFS - Selects the day (from Sunday to Saturday) to play messages.

**A. Turning a message ON or OFF for a day of the week.**

1. Hold RESET and repeatedly push the 2 or 3 key to move the cursor to the day you wish to play a message. Release the RESET key and push POPULAR to enter the play menu for the day you have chosen.
2. Push the message number(s) that you wish to display for the selected day. (If the message number is displayed, the message will be activated if the time ON/OFF is set. If the message number is blanked, that message will not be displayed.) Push POPULAR to save your program settings.

**B. Setting the time of day to play a message (three available ON/OFF time settings per day).**

1. Hold RESET and push 3 to enter the TIME ON menu. Release the RESET key.
2. Determine the time you would like the message to begin playing. Enter the hour and push POPULAR. Enter the minutes and press POPULAR. Hold RESET and push 3 to move to the TIME OFF menu for the selected message. Release the RESET key.
3. Determine the time you would like the message to turn off. Enter the hour and press POPULAR. Enter the minutes and press POPULAR.
4. If additional TIME ON/OFF for this day is required, hold RESET and push 3, then release the RESET key. Go back to step A-2, and go through step B 1-4.
5. When the daily message schedule has been completed for one day, the schedule may then be copied to the other six days by following this procedure:

Hold RESET and push 9 to return to display - MSG SCH SMTWTFS

The letter which is flashing should be the day you have just completed setting up the times for.

Hold RESET and push 8. The display reads CPY XX\* -> S .

To copy the date to the remaining six days, push and hold RESET and push key 3 until the display shows CPY XX\*-> SMTWTFS. Release RESET, then push POPULAR.

\* XX denotes the day ON/OFF times that have been entered.

## Example for setting up the message daily timer

When this example is completed, message 4 will display every day from 12:00 (00:00) midnight until 11:59 (23:59) PM (see Table 2-8 for Display Example).

- A. Follow step BB to obtain display MSG SCH SMTWTFS.
- B. Hold RESET, push 3 once. The M is now flashing. Release RESET.
- C. Push POPULAR.
- D. Push key 4.
- E. Push POPULAR. Hold RESET and push key 3. Release RESET.
- F. Type 00 for the ON hour and push POPULAR.
- G. Type 00 for the ON minute and push POPULAR.
- H. Hold RESET and push key 3. Release RESET.
- I. Type 23 for the OFF hour and push POPULAR.
- J. Type 59 for the OFF minute and push POPULAR.
- K. Hold RESET, push 9. The M should be flashing.
- L. Hold RESET and push key 8 (copy command).
- M. Hold RESET, repeatedly push key 3 until SMTWTFS is displayed. Release RESET. Push POPULAR.

**Table 2-8. Example Message Daily Timer Display**

|   | 1 | 2 | 3 | 4 | 5 | 6 | 7 | 8 | 9 | 10 | 11 | 12 | 13 | 14 | 15 | 16 |
|---|---|---|---|---|---|---|---|---|---|----|----|----|----|----|----|----|
| A |   | M | S | G |   | S | C | H |   | S  | M  | T  | W  | T  | F  | S  |
| B |   | M | S | G |   | S | C | H |   | S  | M  | T  | W  | T  | F  | S  |
| C | M | O | N | - | 1 |   |   |   | - | -  | -  | -  | -  | -  | -  | -  |
| D | M | O | N | - | 1 |   |   |   | - | -  | -  | 4  | -  | -  | -  | -  |
| E | M | O | N | - | 1 |   |   |   | O | N  |    | -  | -  | :  | -  | -  |
| F | M | O | N | - | 1 |   |   |   | O | N  |    | 0  | 0  | :  | 0  | 0  |
| G | M | O | N | - | 1 |   |   |   | O | N  |    | 0  | 0  | :  | 0  | 0  |
| H | M | O | N | - | 1 |   |   | O | F | F  |    | -  | 0  | :  | -  | -  |
| I | M | O | N | - | 1 |   |   | O | F | F  |    | 2  | 3  | :  | 0  | 0  |
| J | M | O | N | - | 1 |   |   | O | F | F  |    | 2  | 3  | :  | 5  | 9  |
| K |   | M | S | G |   | S | C | H |   | S  | M  | T  | W  | T  | F  | S  |
| L | C | P | Y |   | M | O | - | > |   | S  | —  |    |    |    |    |    |
| M | C | P | Y |   | M | O | - | > |   | S  | M  | T  | W  | T  | F  | S  |



## Setting the Master ON/OFF Date: Push 1 (see Note #1 on Page 2-56)

Messages 1-8 can play every day unless they are changed in the MASTER ON/OFF DATE menu. By scheduling messages to play on specific dates, you may tailor messages (such as "HAPPY BIRTHDAY JOE") to play on special dates.

The display screen reads 1 ON 01 01 1997.

This means message "1" is set to begin playing on January 1, 1997.

- A. Setting the ON time for a message.
  1. The message number should be flashing. Type the message number that you desire to create an ON/OFF date for and push POPULAR.
  2. Enter the two-digit month the message is to play and push POPULAR.
  3. Enter the two-digit day the message is to play and push POPULAR.
  4. Enter the four-digit year the message is to play and push POPULAR.
  
- B. Setting the OFF time for the message. Hold RESET and push 3, then release RESET.
  1. The display now reads M\* OFF 12 30 2050. Push POPULAR. (This menu turns the message OFF for the selected date and beyond. M\* should be the message number you created the ON date for.)
  2. Enter the two-digit month the message is to stop playing and push POPULAR to save. Enter the two-digit day the message is to stop playing and push POPULAR to save. Enter the four-digit year the message is to stop playing and push POPULAR to save.

## ENHANCED AUTOPLAY TUTORIAL

### Autoplay

The Autoplay feature stimulates customer interest in the phonograph by periodically playing selections. The Autoplay feature is factory preset to STD and plays one track after the phonograph has been idle for 20 minutes. This feature may be programmed for any length of time between 0 and 255 minutes. Selections may be played in a specific sequence.

### Differences Between Standard and Enhanced Autoplay

Enhanced Autoplay lets you categorize the discs (for example: Popular, Country, Rock, etc.). Up to eight categories can be assigned and selected up to 20 different times of the day, each day of the week. Standard Autoplay cannot assign categories, has one ON/OFF time, and lets you select which days of the week Autoplay is active. Enhanced Autoplay programming is more involved, so Standard Autoplay should be used unless categories, multiple ON/OFF times, or different ON/OFF times for different days are needed.

## SETTING UP ENHANCED AUTOPLAY

1. Set COMMAND 40, AUTOPLAY IS, to: ENH (COMMAND 41, DELAY, is not used in Enhanced Autoplay).
2. Set COMMAND 42, START TIME, to: 00:00 (this is the factory setting).
3. Set COMMAND 43, STOP TIME, to: 23:59 (this is the factory setting).
4. Set COMMAND 44, ON DAYS, to: SMTWTFS (this is the factory setting).
5. COMMAND 45, PROGRAMMED AUTOPLAY - Programming is optional. Use Programmed Autoplay only if you want to play specific selections or play discs in a specific order. If Programmed Autoplay is used, it plays only those selections and discs that are listed in the play list and the discs' categories are selected (the category must be active and the selection must be on the play list before the selection will play).

Enhanced Autoplay looks at the selected categories first, then determines which discs may be played. If one of the allowed category numbers matches a disc category number in the play list, that selection is played. When you use a play list, be sure that the programmed schedule (COMMAND 49), the disc categories (COMMAND 48), and the Programmed Autoplay selections (discs) are properly assigned, or Enhanced Autoplay will not play the selections from the play list. See *Programming Autoplay, Premiums, Priorities, and Lockouts* for information on how to program the play list.



### NOTE:

**COMMAND 46, CLEAR PROGRAMMED, clears all programmed selections entered in COMMAND 45.**

6. Set COMMAND 47, AUTOPLAY STATUS, to: ON.
7. COMMAND 48 and 49. See *Setting Up Enhanced Autoplay Schedules* on the following pages.

## Setting Up Enhanced Autoplay Schedules (Commands 48 and 49)

Enhanced Autoplay provides up to 20 events each day of the week for a total of 140 events per week. Before you begin entering specifics for these events, some preliminary work must be done. If you take the time to do this work now, you will find that planning, entering, and changing the Autoplay schedule will be much easier.

The five major tasks to perform are:

1. Assigning a category number or numbers to each disc installed in the phonograph using the Disc Category List worksheet as shown in *Figure 2-12*. Use the Worksheet Masters at the end of this section for the actual masters.
2. Entering the disc category list into the phonograph.
3. Developing the Autoplay Event Schedule using the Autoplay Event Schedule Worksheet.
4. Entering the Autoplay Event Schedule into the phonograph.
5. Copy a schedule to the other days of the week.

### FOLLOW STEPS 1 THROUGH 5 TO SET UP AN ENHANCED AUTOPLAY SCHEDULE

#### 1. Set Up the Categories

Categories should be assigned if you want to take full advantage of Enhanced Autoplay's ability to select specific kinds of music.

Autoplay sees the eight categories as Category 1 through 8 (all 100 discs are assigned to Category 1 at the factory). To make setting up Autoplay easier, you should assign names to each category. We have supplied a general purpose form to help you assign category numbers and discs. A general purpose category assignment would look like *Figure 2-12*.

Once you have decided what title to use for each category (you do not have to assign a name for each category if you do not have eight categories), you should determine the category (or categories) for each disc. *Figure 2-12* also shows a sample category list for a phonograph with 50 discs. Note that some discs fit into more than one category. This means that Autoplay can select these discs if any one of the categories is scheduled. You can assign a disc to all eight categories, but depending on the category titles, some category titles may exclude each other (it's not likely that a Country & Western disc would be assigned to Urban as well).

You can enter the categories as you look at the title pages on a CD-100K Phonograph.

Photocopy the Disc Category List at the back of this section and use the copy for a work sheet.

## 2. Make the Category Entries

### KEY FUNCTIONS

Some key combinations have slightly different meanings in the Autoplay menus. *Table 2-9* shows what these key combinations do in the Schedule (display shows: SCHEDULESMTWTFS) and in the Set Time (SU01 TIME) modes. Use the DISC mode to enter a disc number. Switch to CATEGORY mode to change the categories assigned to the disc selected in the DISC mode.

Table 2-9. Key Functions

| Key Combination | Function in SCHEDULE SMTWTFS          | Function in SU 01 TIME --:--   |
|-----------------|---------------------------------------|--|
| RESET + 2       | Moves the cursor to the left one day  | Decrements the event number  |
| RESET + 3       | Moves the cursor to the right one day | Increments the event number  |
| RESET + 4       | No function                           | Deletes the current events and moves all events down one line                      |
| RESET + 5       | No function                           | Inserts a blank entry at this event number and pushes all other events up one line |
| RESET + 6       | No function                           | No function  |
| RESET + 7       | No function                           | Toggles the negative sign in VOL1 and VOL2   |
| RESET + 8       | Starts the copy function              | No function  |
| RESET + 9       | Enters the indicated day's program    | Advances to the next programmable field  |
| POPULAR         | Enters the indicated day's program    | Stores the displayed data in the displayed field                                   |

- A. Enter the SERVICE mode.
- B. Enter 48 to access the Autoplay Category menu.

The display will initially show: =00CAT 1-----

- The = sign to the left of the 00 indicates that the disc number will be changed (DISC mode) rather than changing the categories assigned (CATEGORY mode).
- The 00 indicates the disc number
- The 1----- indicates that disc 00 is only assigned to Category 1

## USING RESET + 9 IN THE CATEGORY MENU

RESET + 9 toggles between DISC mode and CATEGORY mode.

### DISC MODE

DISC mode (the = sign is ahead of the disc number) only allows you to change the disc number that is displayed. Use this mode to change the disc number easily. This mode is particularly useful if you are changing or checking categories for a wide range of disc numbers.

**Example:** You want to view the categories assigned to Discs 15, 45, and 87. If you enter 15, you will see the categories assigned to Disc 15. Enter 45 and you will see the categories assigned to Disc 45. Enter 87 and the display shows the categories assigned to Disc 87.

In DISC mode, the following keys have these functions:

| Key Combination | Function  |
|-----------------|---|
| RESET + 2       | Decrements the disc number by one disc  |
| RESET + 3       | Increments the disc number by one disc  |
| POPULAR         | Changes to CATEGORY mode (not a toggle function)  |
| Number Keys     | Numbers entered become the new disc numbers. The new categories are displayed as each digit of the new disc is entered. |

C. Select the disc number that you wish to assign categories.

### CATEGORY MODE

CATEGORY mode (the = sign is ahead of the category numbers) allows you to change the category numbers assigned to a disc.

| Key Combination | Function   |
|-----------------|--|
| RESET + 2       | Decrements the disc number by one disc   |
| RESET + 3       | Increments the disc number by one disc   |
| POPULAR         | Saves any changes made to the category list and increments the disc number by one disc |
| Number Keys     | Toggles the corresponding categories ON and OFF  |

In CATEGORY mode, the following keys have these functions:

D. Press RESET + 9 to switch to CATEGORY mode.

E. Enter the numbers (1 through 8) that correspond to the categories that you wish to assign to the disc. The number keys will alternately turn the category numbers ON and OFF.

### 3. Plan the Schedule

The schedule determines on which day and at what time of day that Autoplay categories are allowed to play (this is called an event).

If the phonograph has the optional volume control module installed, the schedule can adjust the phonograph's volume at the beginning of each event.

The schedule is composed of five parts (seven parts if you include the optional volume control feature). Each of these schedule parts are discussed in the paragraphs that follow.

#### **DAY OF THE WEEK**

The time and date are set at the factory (they can be changed if needed). The factory-set time is Eastern Standard Time.

The Central Control Computer (CCC) uses the time and initial date to determine the day of the week by using its own internal calendar.

If you wish, you may schedule all seven days of the week.

#### **EVENT**

An event is space in the schedule where a schedule change is made. Each of the days of the week can have up to 20 events scheduled.

#### **TIME**

You must supply a time in the schedule to start Enhanced Autoplay. This time is the exact time that you want Autoplay to be allowed to check for an idle phonograph. The actual first Autoplay selection will only play after the delay time (*see Delay*).

#### **CATEGORIES**

All, some, or none of the eight categories can be selected for each event. Select the category (or categories) that you want to have played when the phonograph makes an Autoplay selection. Autoplay will make its selection from the lowest selected category. If you supply a play list (play lists are discussed next), Autoplay will pick a play list selection that is in the selected category.

#### **DELAY**

Delay is the time that Autoplay waits to make a selection after the customer selection is played (is scanned out).

#### **CHANNEL 1 AND CHANNEL 2 VOLUME (4-channel preamp only)**

VOL1 and VOL2 are single digit numbers (0 through 9 and -1 through -9) that cause the phonograph's volume to change in Channel 1 and in Channel 2. This volume change is relative to the volume set by the phonograph's volume control. A volume of 0 means use the phonograph volume control's volume setting. A setting of 1 means boost the volume slightly and a setting of -1 means reduce the volume slightly. A value of 9 is the maximum volume boost and a value of -9 is the maximum volume reduction.

## Working Example of Enhanced Autoplay

### PAUL'S AUTOPLAY SCHEDULE

Paul wants his Rowe Jukebox to automatically play music at certain times of the day. Paul wants to have the music played every day in the following format:

- Easy Listening, at a reduced volume level, for breakfast from 6:30 to 7:30 AM with a one-minute delay between Autoplay selections.
- Top 40 and oldies from 2:00 PM to 4:00 PM with a three-minute delay between Autoplay selections.
- Specials (certain Top 40 discs) from 4:00 to 7:00 PM with a five-minute delay between Autoplay selections.
- All types of music from 7:00 PM to 9:00 PM with an increased volume level.

To accomplish this format, Paul will use Enhanced Autoplay to give the phonograph the exact music style that he desires.

### HOW PAUL SET UP ENHANCED AUTOPLAY

1. Paul reads the tutorial carefully and begins to install Enhanced Autoplay by planning his work first.
2. Paul fills out the Disc Category List (*see Figure 2-12*).

**DISC CATEGORY LIST**

Date 9-13-02

Location Paul's

Name each of the eight categories and then assign the discs to each category.

| Category # | Category Name                    | Category # | Category Name                |
|------------|----------------------------------|------------|------------------------------|
| 1          | <u>All Discs</u>                 | 5          | <u>Urban</u>                 |
| 2          | <u>Pop Music - Top 40</u>        | 6          | <u>Oldies</u>                |
| 3          | <u>Easy Listening</u>            | 7          | <u>Country &amp; Western</u> |
| 4          | <u>Specials - Certain Top 40</u> | 8          | <u>Background Music</u>      |

Place an X on the category that you wish to assign to each disc. (All discs are assigned to category 1 from the factory.)

|    |   |   |   |   |   |   |   |   |    |   |   |   |   |   |   |   |   |
|----|---|---|---|---|---|---|---|---|----|---|---|---|---|---|---|---|---|
| 00 | X | X | 3 | X | 5 | 6 | 7 | 8 | 50 | X | 2 | 3 | 4 | 5 | 6 | 7 | 8 |
| 01 | X | 2 | X | 4 | 5 | 6 | 7 | 8 | 51 | X | 2 | 3 | 4 | 5 | 6 | 7 | 8 |
| 02 | X | X | 3 | 4 | 5 | 6 | 7 | 8 | 52 | X | 2 | 3 | 4 | 5 | 6 | 7 | 8 |
| 03 | X | X | 3 | 4 | 5 | 6 | 7 | 8 | 53 | X | 2 | 3 | 4 | 5 | 6 | 7 | 8 |
| 04 | X | X | 3 | X | 5 | 6 | 7 | 8 | 54 | X | 2 | 3 | 4 | 5 | 6 | 7 | 8 |
| 05 | X | X | 3 | X | 5 | 6 | 7 | 8 | 55 | X | 2 | 3 | 4 | 5 | 6 | 7 | 8 |
| 06 | X | X | X | 4 | 5 | 6 | 7 | X | 56 | X | 2 | 3 | 4 | 5 | 6 | 7 | 8 |
| 07 | X | X | 3 | 4 | 5 | 6 | 7 | 8 | 57 | X | 2 | 3 | 4 | 5 | 6 | 7 | 8 |
| 08 | X | X | 3 | X | 5 | 6 | 7 | 8 | 58 | X | 2 | 3 | 4 | 5 | 6 | 7 | 8 |
| 09 | X | X | 3 | X | 5 | 6 | 7 | 8 | 59 | X | 2 | 3 | 4 | 5 | 6 | 7 | 8 |
| 10 | X | X | 3 | 4 | 5 | 6 | 7 | 8 | 60 | X | 2 | 3 | 4 | 5 | 6 | 7 | 8 |
| 11 | X | 2 | X | 4 | 5 | 6 | 7 | 8 | 61 | X | 2 | 3 | 4 | 5 | 6 | 7 | 8 |
| 12 | X | X | 3 | X | 5 | 6 | X | 8 | 62 | X | 2 | 3 | 4 | 5 | 6 | 7 | 8 |
| 13 | X | X | 3 | 4 | 5 | 6 | 7 | 8 | 63 | X | 2 | 3 | 4 | 5 | 6 | 7 | 8 |
| 14 | X | 2 | 3 | 4 | 5 | 6 | 7 | 8 | 64 | X | 2 | 3 | 4 | 5 | 6 | 7 | 8 |
| 15 | X | X | 3 | 4 | 5 | 6 | 7 | 8 | 65 | X | 2 | 3 | 4 | 5 | 6 | 7 | 8 |
| 16 | X | X | 3 | X | 5 | 6 | 7 | 8 | 66 | X | 2 | 3 | 4 | 5 | 6 | 7 | 8 |
| 17 | X | X | 3 | 4 | 5 | 6 | 7 | 8 | 67 | X | 2 | 3 | 4 | 5 | 6 | 7 | 8 |
| 18 | X | 2 | 3 | 4 | 5 | 6 | 7 | X | 68 | X | 2 | 3 | 4 | 5 | 6 | 7 | 8 |
| 19 | X | 2 | 3 | 4 | 5 | 6 | 7 | 8 | 69 | X | 2 | 3 | 4 | 5 | 6 | 7 | 8 |
| 20 | X | 2 | 3 | 4 | 5 | 6 | 7 | 8 | 70 | X | 2 | 3 | 4 | 5 | 6 | 7 | 8 |
| 21 | X | 2 | 3 | 4 | 5 | 6 | 7 | 8 | 71 | X | 2 | 3 | 4 | 5 | 6 | 7 | 8 |
| 22 | X | 2 | 3 | 4 | 5 | 6 | 7 | 8 | 72 | X | 2 | 3 | 4 | 5 | 6 | 7 | 8 |
| 23 | X | X | 3 | X | 5 | 6 | 7 | X | 73 | X | 2 | 3 | 4 | 5 | 6 | 7 | 8 |
| 24 | X | 2 | 3 | 4 | 5 | 6 | 7 | 8 | 74 | X | 2 | 3 | 4 | 5 | 6 | 7 | 8 |
| 25 | X | 2 | 3 | 4 | 5 | 6 | 7 | 8 | 75 | X | 2 | 3 | 4 | 5 | 6 | 7 | 8 |
| 26 | X | 2 | 3 | 4 | 5 | 6 | 7 | 8 | 76 | X | 2 | 3 | 4 | 5 | 6 | 7 | 8 |
| 27 | X | 2 | 3 | 4 | 5 | 6 | 7 | 8 | 77 | X | 2 | 3 | 4 | 5 | 6 | 7 | 8 |
| 28 | X | X | 3 | X | 5 | 6 | 7 | X | 78 | X | 2 | 3 | 4 | 5 | 6 | 7 | 8 |
| 29 | X | X | 3 | 4 | 5 | 6 | 7 | 8 | 79 | X | 2 | 3 | 4 | 5 | 6 | 7 | 8 |
| 30 | X | X | 3 | 4 | 5 | 6 | 7 | 8 | 80 | X | 2 | 3 | 4 | 5 | 6 | 7 | 8 |
| 31 | X | X | 3 | 4 | 5 | 6 | 7 | 8 | 81 | X | 2 | 3 | 4 | 5 | 6 | 7 | 8 |
| 32 | X | X | 3 | 4 | 5 | 6 | 7 | 8 | 82 | X | 2 | 3 | 4 | 5 | 6 | 7 | 8 |
| 33 | X | X | 3 | 4 | 5 | 6 | 7 | 8 | 83 | X | 2 | 3 | 4 | 5 | 6 | 7 | 8 |
| 34 | X | X | 3 | 4 | 5 | 6 | 7 | 8 | 84 | X | 2 | 3 | 4 | 5 | 6 | 7 | 8 |
| 35 | X | X | 3 | 4 | 5 | 6 | 7 | 8 | 85 | X | 2 | 3 | 4 | 5 | 6 | 7 | 8 |
| 36 | X | X | X | 4 | 5 | 6 | 7 | 8 | 86 | X | 2 | 3 | 4 | 5 | 6 | 7 | 8 |
| 37 | X | 2 | X | 4 | 5 | 6 | 7 | 8 | 87 | X | 2 | 3 | 4 | 5 | 6 | 7 | 8 |
| 38 | X | 2 | X | 4 | 5 | 6 | 7 | X | 88 | X | 2 | 3 | 4 | 5 | 6 | 7 | 8 |
| 39 | X | 2 | X | 4 | 5 | 6 | 7 | 8 | 89 | X | 2 | 3 | 4 | 5 | 6 | 7 | 8 |
| 40 | X | 2 | X | 4 | 5 | 6 | 7 | 8 | 90 | X | 2 | 3 | 4 | 5 | 6 | 7 | 8 |
| 41 | X | 2 | X | 4 | 5 | 6 | 7 | X | 91 | X | 2 | 3 | 4 | 5 | 6 | 7 | 8 |
| 42 | X | 2 | X | 4 | 5 | 6 | 7 | 8 | 92 | X | 2 | 3 | 4 | 5 | 6 | 7 | 8 |
| 43 | X | 2 | X | 4 | 5 | 6 | 7 | 8 | 93 | X | 2 | 3 | 4 | 5 | 6 | 7 | 8 |
| 44 | X | 2 | 3 | 4 | X | 6 | 7 | 8 | 94 | X | 2 | 3 | 4 | 5 | 6 | 7 | 8 |
| 45 | X | 2 | 3 | 4 | X | 6 | 7 | 8 | 95 | X | 2 | 3 | 4 | 5 | 6 | 7 | 8 |
| 46 | X | 2 | X | 4 | X | 6 | 7 | 8 | 96 | X | 2 | 3 | 4 | 5 | 6 | 7 | 8 |
| 47 | X | 2 | 3 | 4 | X | 6 | 7 | 8 | 97 | X | 2 | 3 | 4 | 5 | 6 | 7 | 8 |
| 48 | X | 2 | 3 | 4 | X | 6 | 7 | 8 | 98 | X | 2 | 3 | 4 | 5 | 6 | 7 | 8 |
| 49 | X | 2 | 3 | 4 | X | 6 | 7 | 8 | 99 | X | 2 | 3 | 4 | 5 | 6 | 7 | 8 |

**Figure 2-12. Sample Disc Category List**



3. Paul then enters the information shown in *Figure 2-12* in the following sequence:
- A. Paul enters the SERVICE mode. The list that follows shows what keys he presses and displays what he sees after he presses the keys.
  - B. The Steps:

| Step # | Keystroke                | Display          |
|--------|--------------------------|------------------|
| 1      | COMMAND 40               | AUTOPLAY IS STD  |
| 2      | RESET + 9                | AUTOPLAY IS ENH  |
| 3      | POPULAR                  |                  |
| 4      | RESET + POPULAR          | *AUTOPLAY*       |
| 5      | RESET + POPULAR          | SERVICE MODE     |
| 6      | COMMAND 48               | =00 CAT 1-----   |
| 7      | RESET + 9                | 00 CAT=1-----    |
| 8      | Press Key 2, Press Key 4 | 00 CAT=12-4----- |
| 9      | POPULAR                  | 01 CAT=1-----    |
| 10     | Press Key 3              | 01 CAT=1-3-----  |
| 11     | POPULAR                  | 02 CAT=1-----    |

Paul repeats Steps 8, 9, 10, and 11 to assign all discs according to the Disc Category List. In Step 8 and 10, he presses the necessary keys (1-8) to delete (unassigned categories display as a dash) and assign (assigned categories display as the category number) the categories. When he finishes, Paul will have assigned categories to 50 of the 100 discs possible (some discs will have been assigned to multiple categories).

Note that the factory has assigned all discs to Category 1, and Paul may choose to turn Category 1 OFF while he assigns categories.

- C. Next, Paul fills out the Autoplay Schedule according to his schedule (*see Figure 2-13*).

### AUTOPLAY SCHEDULE

**Location: Paul's Restaurant**

**Date: 6-8-95**

Fill in the Autoplay event times, delay times, categories, and volume changes before you make the actual scheduling changes.

**Day: SMTWTFS**

| Event | Time    | Categories | Delay | Vol 1 | Vol 2 |
|-------|---------|------------|-------|-------|-------|
| 1     | 6 : 30  | 3          | 1     | -3    | -3    |
| 2     | 7 : 30  |            | 0     | 0     | 0     |
| 3     | 14 : 00 | 2,6        | 3     | 0     | 0     |
| 4     | 16 : 00 | 4          | 5     | 0     | 0     |
| 5     | 19 : 00 | 1          | 0     | +3    | +3    |
| 6     | 21 : 00 |            | 0     | 0     | -3    |

**Figure 2-13. Sample Autoplay Schedule**

- D. Paul now enters the SERVICE mode and begins to make the entries.  
The steps are:

| Step # | Keystroke                               | Display           |
|--------|---|-------------------|
| 1      | COMMAND 49                              | SCHEDULE SMTWTFS  |
| 2      | POPULAR                                 | SU 01 TIME --:--  |
| 3      | Press Keys 0, 6, POPULAR, 3, 0, POPULAR | SU 01 TIME 06:30  |
| 4      | Press RESET + 9                         | SU 01 [ -----]    |
| 5      | Press Keys 3, POPULAR                   | SU 01 [ --3-----] |
| 6      | Press RESET + 9                         | SU 01 DELAY 00    |
| 7      | Press Keys 1, POPULAR                   | SU 01 DELAY 01    |
| 8      | Press RESET + 9                         | SU 01 VOL CH10    |
| 9      | Press RESET + 7, 3, POPULAR             | SU 01 VOL CH1 -3  |
| 10     | Press RESET + 9                         | SU 01 VOL CH20    |
| 11     | POPULAR                                 | SU 01 VOL CH2 -3  |
| 12     | Press RESET + 9                         | SU 01 TIME 06:30  |
| 13     | Press RESET + 3                         | SU 01 TIME --:--  |

| Step # | Keystroke                               | Display           |
|--------|---|-------------------|
| 14     | Press Keys 0, 7, POPULAR, 3, 0, POPULAR | SU 02 TIME 7:30   |
| 15     | Press RESET + 9                         | SU 02 [ -----]    |
| 16     | Press RESET + 9                         | SU 02 DELAY 00    |
| 17     | Press RESET + 9                         | SU 02 VOL CH1 0   |
| 18     | Press RESET + 9                         | SU 02 VOL CH2 0   |
| 19     | Press RESET + 9                         | SU 02 TIME 7:30   |
| 20     | Press RESET + 3                         | SU 02 TIME --:--  |
| 21     | Press Keys 1, 4, POPULAR, POPULAR       | SU 03 TIME 14:00  |
| 22     | Press RESET + 9                         | SU 03 [ -----]    |
| 23     | Press Keys 2, 6, and then POPULAR       | SU 03 [ -2---6--] |
| 24     | Press RESET + 9                         | SU 03 DELAY 00    |
| 25     | Press Keys 3, POPULAR                   | SU 03 DELAY 03    |
| 26     | Press RESET + 9                         | SU 03 VOL CH1 0   |
| 27     | Press RESET + 9                         | SU 03 VOL CH2 0   |
| 28     | Press RESET + 9                         | SU 03 TIME 14:00  |
| 29     | Press RESET + 3                         | SU 04 TIME --:--  |
| 30     | Press 1, 6, POPULAR, POPULAR            | SU 04 TIME 16:00  |
| 31     | Press RESET + 9                         | SU 04 [ -----]    |
| 32     | Press Keys 4, POPULAR                   | SU 04 [ ---4----  |
| 33     | Press RESET + 9                         | SU 04 DELAY 00    |
| 34     | Press Keys 5, POPULAR                   | SU 04 DELAY 05    |
| 35     | Press RESET + 9                         | SU 04 VOL CH1 0   |
| 36     | Press RESET + 9                         | SU 04 VOL CH2 0   |
| 37     | Press RESET + 9                         | SU 04 TIME 16:00  |
| 38     | Press RESET + 3                         | SU 05 TIME --:--  |
| 39     | Press 1, 9, POPULAR, POPULAR            | SU 05 TIME 19:00  |
| 40     | Press RESET + 9                         | SU 05 [ -----]    |
| 41     | Press RESET + 3                         | SU 05 [ 1-----]   |
| 42     | Press RESET + 9                         | SU 05 DELAY 00    |

| Step # | Keystroke                         | Display          |
|--------|-----------------------------------|------------------|
| 43     | Press RESET + 9                   | SU 05 VOL CH1 0  |
| 44     | Press Keys 3, POPULAR             | SU 05 VOL CH1 3  |
| 45     | Press RESET + 9                   | SU 05 VOL CH2 0  |
| 46     | Press Keys 3, POPULAR             | SU 05 VOL CH2 3  |
| 47     | Press RESET + 9                   | SU 05 TIME 19:00 |
| 48     | Press RESET + 3                   | SU 05 TIME --:-- |
| 49     | Press Keys 2, 1, POPULAR, POPULAR | SU 06 TIME 21:00 |
| 50     | Press RESET + 9                   | SU 06 [ -----]   |
| 51     | Press RESET + 9                   | SU 06 DELAY 00   |
| 52     | Press RESET + 9                   | SU 06 VOL CH1 0  |
| 53     | Press RESET + 9                   | SU 06 VOL CH2 0  |
| 54     | Press RESET + 9                   | SU 06 TIME 21:00 |

This completes the entries for the 6 events on Sunday's schedule.

### Copying the Schedule

The last step is to program the phonograph for the rest of the week. Paul decides to save some time by copying the schedule into the remaining days of the week. To make the schedule for Monday through Saturday the same as Sunday. (The Copy function is also helpful if the schedule for the other days is similar to the Sunday schedule. Do a Copy and then revise the copied schedules.)

| Step # | Keystroke                   | Display          |
|--------|-----------------------------|------------------|
| 1      | Press RESET + POPULAR twice | SERVICE MODE     |
| 2      | Press Keys 4, 9             | SCHEDULE SMTWTFS |
| 3      | Press RESET + 8             | CPY SU-> S       |
| 4      | Press RESET + 2 twice       | CPY SU-> SMTWTFS |
| 5      | Press POPULAR               | SCHEDULE SMTWTFS |

This page intentionally left blank.

# Worksheet Masters



On the following pages you will find blank worksheet masters for *Multiple Free Play On/Off Times*, the *Disc Category List*, and the *Autoplay Schedule*.

Carefully remove these masters from this manual and copy them freely for your use. Note that extra room has been left on the left-hand margin of each sheet so that it may be hole-punched and kept in a binder for future reference.





## DISC CATEGORY LIST

Date \_\_\_\_\_

Location \_\_\_\_\_

Name each of the eight categories and then assign the discs to each category.

| Category # | Category Name | Category # | Category Name |
|------------|---------------|------------|---------------|
| 1          | _____         | 5          | _____         |
| 2          | _____         | 6          | _____         |
| 3          | _____         | 7          | _____         |
| 4          | _____         | 8          | _____         |

Place an X on the category that you wish to assign to each disc. (All discs are assigned to category 1 from the factory.)

|    |   |   |   |   |   |   |   |   |    |   |   |   |   |   |   |   |   |
|----|---|---|---|---|---|---|---|---|----|---|---|---|---|---|---|---|---|
| 00 | 1 | 2 | 3 | 4 | 5 | 6 | 7 | 8 | 50 | 1 | 2 | 3 | 4 | 5 | 6 | 7 | 8 |
| 01 | 1 | 2 | 3 | 4 | 5 | 6 | 7 | 8 | 51 | 1 | 2 | 3 | 4 | 5 | 6 | 7 | 8 |
| 02 | 1 | 2 | 3 | 4 | 5 | 6 | 7 | 8 | 52 | 1 | 2 | 3 | 4 | 5 | 6 | 7 | 8 |
| 03 | 1 | 2 | 3 | 4 | 5 | 6 | 7 | 8 | 53 | 1 | 2 | 3 | 4 | 5 | 6 | 7 | 8 |
| 04 | 1 | 2 | 3 | 4 | 5 | 6 | 7 | 8 | 54 | 1 | 2 | 3 | 4 | 5 | 6 | 7 | 8 |
| 05 | 1 | 2 | 3 | 4 | 5 | 6 | 7 | 8 | 55 | 1 | 2 | 3 | 4 | 5 | 6 | 7 | 8 |
| 06 | 1 | 2 | 3 | 4 | 5 | 6 | 7 | 8 | 56 | 1 | 2 | 3 | 4 | 5 | 6 | 7 | 8 |
| 07 | 1 | 2 | 3 | 4 | 5 | 6 | 7 | 8 | 57 | 1 | 2 | 3 | 4 | 5 | 6 | 7 | 8 |
| 08 | 1 | 2 | 3 | 4 | 5 | 6 | 7 | 8 | 58 | 1 | 2 | 3 | 4 | 5 | 6 | 7 | 8 |
| 09 | 1 | 2 | 3 | 4 | 5 | 6 | 7 | 8 | 59 | 1 | 2 | 3 | 4 | 5 | 6 | 7 | 8 |
| 10 | 1 | 2 | 3 | 4 | 5 | 6 | 7 | 8 | 60 | 1 | 2 | 3 | 4 | 5 | 6 | 7 | 8 |
| 11 | 1 | 2 | 3 | 4 | 5 | 6 | 7 | 8 | 61 | 1 | 2 | 3 | 4 | 5 | 6 | 7 | 8 |
| 12 | 1 | 2 | 3 | 4 | 5 | 6 | 7 | 8 | 62 | 1 | 2 | 3 | 4 | 5 | 6 | 7 | 8 |
| 13 | 1 | 2 | 3 | 4 | 5 | 6 | 7 | 8 | 63 | 1 | 2 | 3 | 4 | 5 | 6 | 7 | 8 |
| 14 | 1 | 2 | 3 | 4 | 5 | 6 | 7 | 8 | 64 | 1 | 2 | 3 | 4 | 5 | 6 | 7 | 8 |
| 15 | 1 | 2 | 3 | 4 | 5 | 6 | 7 | 8 | 65 | 1 | 2 | 3 | 4 | 5 | 6 | 7 | 8 |
| 16 | 1 | 2 | 3 | 4 | 5 | 6 | 7 | 8 | 66 | 1 | 2 | 3 | 4 | 5 | 6 | 7 | 8 |
| 17 | 1 | 2 | 3 | 4 | 5 | 6 | 7 | 8 | 67 | 1 | 2 | 3 | 4 | 5 | 6 | 7 | 8 |
| 18 | 1 | 2 | 3 | 4 | 5 | 6 | 7 | 8 | 68 | 1 | 2 | 3 | 4 | 5 | 6 | 7 | 8 |
| 19 | 1 | 2 | 3 | 4 | 5 | 6 | 7 | 8 | 69 | 1 | 2 | 3 | 4 | 5 | 6 | 7 | 8 |
| 20 | 1 | 2 | 3 | 4 | 5 | 6 | 7 | 8 | 70 | 1 | 2 | 3 | 4 | 5 | 6 | 7 | 8 |
| 21 | 1 | 2 | 3 | 4 | 5 | 6 | 7 | 8 | 71 | 1 | 2 | 3 | 4 | 5 | 6 | 7 | 8 |
| 22 | 1 | 2 | 3 | 4 | 5 | 6 | 7 | 8 | 72 | 1 | 2 | 3 | 4 | 5 | 6 | 7 | 8 |
| 23 | 1 | 2 | 3 | 4 | 5 | 6 | 7 | 8 | 73 | 1 | 2 | 3 | 4 | 5 | 6 | 7 | 8 |
| 24 | 1 | 2 | 3 | 4 | 5 | 6 | 7 | 8 | 74 | 1 | 2 | 3 | 4 | 5 | 6 | 7 | 8 |
| 25 | 1 | 2 | 3 | 4 | 5 | 6 | 7 | 8 | 75 | 1 | 2 | 3 | 4 | 5 | 6 | 7 | 8 |
| 26 | 1 | 2 | 3 | 4 | 5 | 6 | 7 | 8 | 76 | 1 | 2 | 3 | 4 | 5 | 6 | 7 | 8 |
| 27 | 1 | 2 | 3 | 4 | 5 | 6 | 7 | 8 | 77 | 1 | 2 | 3 | 4 | 5 | 6 | 7 | 8 |
| 28 | 1 | 2 | 3 | 4 | 5 | 6 | 7 | 8 | 78 | 1 | 2 | 3 | 4 | 5 | 6 | 7 | 8 |
| 29 | 1 | 2 | 3 | 4 | 5 | 6 | 7 | 8 | 79 | 1 | 2 | 3 | 4 | 5 | 6 | 7 | 8 |
| 30 | 1 | 2 | 3 | 4 | 5 | 6 | 7 | 8 | 80 | 1 | 2 | 3 | 4 | 5 | 6 | 7 | 8 |
| 31 | 1 | 2 | 3 | 4 | 5 | 6 | 7 | 8 | 81 | 1 | 2 | 3 | 4 | 5 | 6 | 7 | 8 |
| 32 | 1 | 2 | 3 | 4 | 5 | 6 | 7 | 8 | 82 | 1 | 2 | 3 | 4 | 5 | 6 | 7 | 8 |
| 33 | 1 | 2 | 3 | 4 | 5 | 6 | 7 | 8 | 83 | 1 | 2 | 3 | 4 | 5 | 6 | 7 | 8 |
| 34 | 1 | 2 | 3 | 4 | 5 | 6 | 7 | 8 | 84 | 1 | 2 | 3 | 4 | 5 | 6 | 7 | 8 |
| 35 | 1 | 2 | 3 | 4 | 5 | 6 | 7 | 8 | 85 | 1 | 2 | 3 | 4 | 5 | 6 | 7 | 8 |
| 36 | 1 | 2 | 3 | 4 | 5 | 6 | 7 | 8 | 86 | 1 | 2 | 3 | 4 | 5 | 6 | 7 | 8 |
| 37 | 1 | 2 | 3 | 4 | 5 | 6 | 7 | 8 | 87 | 1 | 2 | 3 | 4 | 5 | 6 | 7 | 8 |
| 38 | 1 | 2 | 3 | 4 | 5 | 6 | 7 | 8 | 88 | 1 | 2 | 3 | 4 | 5 | 6 | 7 | 8 |
| 39 | 1 | 2 | 3 | 4 | 5 | 6 | 7 | 8 | 89 | 1 | 2 | 3 | 4 | 5 | 6 | 7 | 8 |
| 40 | 1 | 2 | 3 | 4 | 5 | 6 | 7 | 8 | 90 | 1 | 2 | 3 | 4 | 5 | 6 | 7 | 8 |
| 41 | 1 | 2 | 3 | 4 | 5 | 6 | 7 | 8 | 91 | 1 | 2 | 3 | 4 | 5 | 6 | 7 | 8 |
| 42 | 1 | 2 | 3 | 4 | 5 | 6 | 7 | 8 | 92 | 1 | 2 | 3 | 4 | 5 | 6 | 7 | 8 |
| 43 | 1 | 2 | 3 | 4 | 5 | 6 | 7 | 8 | 93 | 1 | 2 | 3 | 4 | 5 | 6 | 7 | 8 |
| 44 | 1 | 2 | 3 | 4 | 5 | 6 | 7 | 8 | 94 | 1 | 2 | 3 | 4 | 5 | 6 | 7 | 8 |
| 45 | 1 | 2 | 3 | 4 | 5 | 6 | 7 | 8 | 95 | 1 | 2 | 3 | 4 | 5 | 6 | 7 | 8 |
| 46 | 1 | 2 | 3 | 4 | 5 | 6 | 7 | 8 | 96 | 1 | 2 | 3 | 4 | 5 | 6 | 7 | 8 |
| 47 | 1 | 2 | 3 | 4 | 5 | 6 | 7 | 8 | 97 | 1 | 2 | 3 | 4 | 5 | 6 | 7 | 8 |
| 48 | 1 | 2 | 3 | 4 | 5 | 6 | 7 | 8 | 98 | 1 | 2 | 3 | 4 | 5 | 6 | 7 | 8 |
| 49 | 1 | 2 | 3 | 4 | 5 | 6 | 7 | 8 | 99 | 1 | 2 | 3 | 4 | 5 | 6 | 7 | 8 |

**Figure 2-12. Sample Disc Category List**





**MULTIPLE FREE PLAY ON/OFF TIMES**

Fill in the START times, STOP times, and the COMMENTS before you make the actual scheduling changes.

| <b>Sunday</b> | <b>On</b> | <b>Off</b> | <b>Comment</b> |
|---------------|-----------|------------|----------------|
| 1             | —:—       | —:—        | _____          |
| 2             | —:—       | —:—        | _____          |
| 3             | —:—       | —:—        | _____          |

| <b>Monday</b> | <b>On</b> | <b>Off</b> | <b>Comment</b> |
|---------------|-----------|------------|----------------|
| 1             | —:—       | —:—        | _____          |
| 2             | —:—       | —:—        | _____          |
| 3             | —:—       | —:—        | _____          |

| <b>Tuesday</b> | <b>On</b> | <b>Off</b> | <b>Comment</b> |
|----------------|-----------|------------|----------------|
| 1              | —:—       | —:—        | _____          |
| 2              | —:—       | —:—        | _____          |
| 3              | —:—       | —:—        | _____          |

| <b>Wednesday</b> | <b>On</b> | <b>Off</b> | <b>Comment</b> |
|------------------|-----------|------------|----------------|
| 1                | —:—       | —:—        | _____          |
| 2                | —:—       | —:—        | _____          |
| 3                | —:—       | —:—        | _____          |

| <b>Thursday</b> | <b>On</b> | <b>Off</b> | <b>Comment</b> |
|-----------------|-----------|------------|----------------|
| 1               | —:—       | —:—        | _____          |
| 2               | —:—       | —:—        | _____          |
| 3               | —:—       | —:—        | _____          |

| <b>Friday</b> | <b>On</b> | <b>Off</b> | <b>Comment</b> |
|---------------|-----------|------------|----------------|
| 1             | —:—       | —:—        | _____          |
| 2             | —:—       | —:—        | _____          |
| 3             | —:—       | —:—        | _____          |

| <b>Saturday</b> | <b>On</b> | <b>Off</b> | <b>Comment</b> |
|-----------------|-----------|------------|----------------|
| 1               | —:—       | —:—        | _____          |
| 2               | —:—       | —:—        | _____          |
| 3               | —:—       | —:—        | _____          |



# AUTOPLAY EVENT SCHEDULE

Day: \_\_\_\_\_

Location \_\_\_\_\_

Fill in the Autoplay event times, delay times, categories, and volume changes before you make the actual scheduling changes.

Day: \_\_\_\_\_

| Event | Time   | Categories | Delay | Vol 1 | Vol 2 |
|-------|--------|------------|-------|-------|-------|
| 1     | _____: | _____      | _____ | _____ | _____ |
| 2     | _____: | _____      | _____ | _____ | _____ |
| 3     | _____: | _____      | _____ | _____ | _____ |
| 4     | _____: | _____      | _____ | _____ | _____ |
| 5     | _____: | _____      | _____ | _____ | _____ |
| 6     | _____: | _____      | _____ | _____ | _____ |
| 7     | _____: | _____      | _____ | _____ | _____ |
| 8     | _____: | _____      | _____ | _____ | _____ |
| 9     | _____: | _____      | _____ | _____ | _____ |
| 10    | _____: | _____      | _____ | _____ | _____ |
| 11    | _____: | _____      | _____ | _____ | _____ |
| 12    | _____: | _____      | _____ | _____ | _____ |
| 13    | _____: | _____      | _____ | _____ | _____ |
| 14    | _____: | _____      | _____ | _____ | _____ |
| 15    | _____: | _____      | _____ | _____ | _____ |
| 16    | _____: | _____      | _____ | _____ | _____ |
| 17    | _____: | _____      | _____ | _____ | _____ |
| 18    | _____: | _____      | _____ | _____ | _____ |
| 19    | _____: | _____      | _____ | _____ | _____ |
| 20    | _____: | _____      | _____ | _____ | _____ |



SERIAL# \_\_\_\_\_ LOCATION \_\_\_\_\_

ROWE CD PHONO  
OPERATOR'S SETUP SHEET

**SUGGESTION:** Record any changes on this log and keep for future reference.

**INSTRUCTIONS** 1. Items in parentheses do not appear on the digital display.  
2. Customer fills in blanks where program differs from factory settings.

| MENU<br>COMMAND         | MENU<br>NAME                    | FACTORY<br>SETTINGS               | OPERATOR<br>CHANGES |
|-------------------------|---------------------------------|-----------------------------------|---------------------|
| <b>*SECURITY*</b>       |                                 |                                   |                     |
| 02                      | LVL 2 CODE                      | 0000                              | _____               |
| 03                      | LVL 3 CODE                      | 0000                              | _____               |
| 04                      | PHONO ID                        | 0000                              | _____               |
| 05                      | VOID SRVC SW (ON/OFF)           | OFF                               | _____               |
| 06                      | SECURITY IS (ON/OFF)            | OFF                               | _____               |
| <b>*MODEM*</b>          |                                 |                                   |                     |
| 080                     | MODEM PASSWORD                  | 0000000                           | _____               |
| 081                     | MODEM ANSWER ON TIME            | 05:00                             | _____               |
| 082                     | MODEM ANSWER OFF TIME           | 06:00                             | _____               |
| 083                     | MODEM #OF RINGS TO<br>ANSWER ON | 2                                 | _____               |
| 084                     | MODEM RECV (ON/OFF)             | OFF                               | _____               |
| 085                     | CONNECT DELAY                   | 9                                 | _____               |
| 086                     | MODEM XMT INIT                  | M0E0\N                            | _____               |
| 087                     | MODEM RCV INIT                  | M0E0\N                            | _____               |
| <b>*MODEM SPECIAL*</b>  |                                 |                                   |                     |
| 0890                    | MODEM POST (ON/OFF)             | OFF                               | _____               |
| 0891                    | DAYS ACT                        | SMTWTFS                           | _____               |
| 0892                    | POST ON                         | 00:00                             | _____               |
| 0893                    | POST OFF                        | 00:00                             | _____               |
| 0894                    | POST TELEPHONE #                | ATDT                              | _____               |
| 0895                    | RETRIES                         | 1                                 | _____               |
| 0896                    | MODEM PAGE (ON/OFF)             | OFF                               | _____               |
| 0897                    | PAGE TO POST (ON/OFF)           | OFF                               | _____               |
| 0898                    | PAGE TELEPHONE #                | ATDT                              | _____               |
| 0899                    | PAGE SUFFIX                     |                                   | _____               |
| <b>*ATTRACT*</b>        |                                 |                                   |                     |
| 20                      | ATTRACT MODE (ON/OFF)           | ON                                | _____               |
| 21                      | PAGE MODE (AD/OFF/CHG)          | AD                                | _____               |
| 22                      | CHANGE TIME (# MINUTES)         | 30                                | _____               |
| 23                      | DISPLAY PAGE (PAGE #)           | 1                                 | _____               |
| 24                      | PAGE IN - OUT (1 - 9)           | IN-1 OUT-9                        | IN _____ OUT _____  |
| 25                      | SPEED IN - OUT (1 - 9)          | IN-5 OUT-5                        | IN _____ OUT _____  |
| 26                      | SLED RESET                      | 300                               | _____               |
| 28                      | PIEZO TIME                      | 150                               | _____               |
| 29                      | PLAY DELAY                      | 0                                 | _____               |
| <b>*MESSAGE CENTER*</b> |                                 |                                   |                     |
| 270                     | MSG DAILY SCHEDULER             | (ALL MSGS<br>DISABLED)            | _____               |
| 271                     | MSG DATE SCHEDULER              | (MSGS 1-8<br>ACTIVE ALL<br>DATES) | _____               |
| 272                     | MSG EDITOR                      | (MSGS 1-8 BLANK)                  | _____               |
| 274                     | 4 HOUR CLEAR (ON/OFF)           | ON                                | _____               |
| 278                     | VIDEO CD's (OFF/JUK/ON)         | OFF                               | _____               |



| MENU<br>COMMAND | MENU<br>NAME                     | FACTORY<br>SETTINGS | OPERATOR<br>CHANGES           |
|-----------------|----------------------------------|---------------------|-------------------------------|
|                 | <b>*INITIALIZE*</b>              |                     |                               |
| 35              | CONDITION LOG                    | 05                  | _____                         |
| 36              | SKIP CANCEL                      | 99                  | _____                         |
| 37              | TIME CANCEL                      | 99                  | _____                         |
| 38              | TIME <sup>1</sup>                | EASTERN STD.        | _____ : _____ :               |
| 39              | DATE <sup>2</sup>                |                     | _____                         |
|                 | <b>* AUTO PLAY *<sup>3</sup></b> |                     |                               |
| 40              | AUTO PLAY IS (STD/ENH/CDT/OFF)   | STD                 | _____                         |
| 41              | DELAY TIME (# MINUTES)           | 20                  | _____                         |
| 42              | START TIME (TIME OF DAY)         | 00:00               | _____                         |
| 43              | STOP TIME (TIME OF DAY)          | 23:59               | _____                         |
| 44              | ON DAYS                          | SMTWTFS             | _____                         |
| 45              | PROGRAM                          | 00                  | 00<br>01<br>02<br>03<br>_____ |
| 47              | APLAY STATUS (ON/OFF)            | ON                  | _____                         |
| 48              | (ENH APLAY)                      | =00 CAT 1-----      | _____                         |
| 49              | SCHEDULE                         | SMTWTFS             | _____                         |
|                 | <b>* PRICING *</b>               |                     |                               |
| 53              | MULTIPLIER                       | 5                   | _____                         |
| 54              | TIMED FPLAY (ON/OFF)             | OFF                 | _____                         |
| 55              | FPLAY STATUS (ON/OFF)            | OFF                 | _____                         |
| 56              | SHORT PULSES (ON/OFF)            | OFF                 | _____                         |
| 58              | FREE SCH <sup>4</sup>            | SMTWTFS             | _____                         |
| 59              | COUNTRY<br>(US/UK/AUSTRA/CANADA) | = US                | _____                         |
|                 | <b>* COIN SW VALUES *</b>        |                     |                               |
| 501             | COIN SW 1                        | 1                   | _____                         |
| 502             | COIN SW 2                        | 2                   | _____                         |
| 503             | COIN SW 3                        | 5                   | _____                         |
| 504             | COIN SW 4                        | 20                  | _____                         |
| 505             | COIN SW 5                        | 20                  | _____                         |
| 506             | COIN/BILL 6                      | 20                  | _____                         |
| 507             | BILL 1                           | 20                  | _____                         |
| 508             | BILL 2                           | 100                 | _____                         |
| 509             | COIN/BILL 6 (BILL/COIN)          | BILL                | _____                         |
|                 | <b>* PRICE LEVELS *</b>          |                     |                               |
| 511             | LVL 1 PRICE                      | 100                 | _____                         |
| 512             | LVL 2 PRICE                      | 200                 | _____                         |
| 513             | LVL 3 PRICE                      | 500                 | _____                         |
| 514             | LVL 4 PRICE                      | 0                   | _____                         |
| 515             | LVL 5 PRICE                      | 0                   | _____                         |
|                 | <b>* PLAY @ LEVELS *</b>         |                     |                               |
| 521             | LVL 1 PLAYS    ALT 1 PLAYS       | 2                   | _____                         |
| 522             | LVL 2 PLAYS    ALT 2 PLAYS       | 5                   | _____                         |
| 523             | LVL 3 PLAYS    ALT 3 PLAYS       | 15                  | _____                         |
| 524             | LVL 4 PLAYS    ALT 4 PLAYS       | 0                   | _____                         |
| 525             | LVL 5 PLAYS    ALT 5 PLAYS       | 0                   | _____                         |
| 526             | ALT PRC ON                       | 00:00               | _____                         |
| 527             | ALT PRC OFF                      | 00:00               | _____                         |
| 528             | MY SNG FIRST (ON/OFF)            | ON                  | _____                         |
| 529             | MSF CREDITS                      | 2                   | _____                         |





| MENU<br>COMMAND | MENU<br>NAME   | FACTORY<br>SETTINGS | OPERATOR<br>CHANGES                      |
|-----------------|--|---------------------|--|
|                 | <b>* OPTIONS *</b>   |                     |  |
| 60              | LOCKOUTS (50 MAX) <sup>5</sup>   | 00_____             | 00_____<br>01_____<br>02_____<br>03_____ |
| 61              | PRIORITY (100 MAX) <sup>5</sup>  | 00_____             | 00_____<br>01_____<br>02_____<br>03_____ |
| 62              | PREMIUMS (100 MAX) <sup>5</sup>  | 00_____             | 00_____<br>01_____<br>02_____<br>03_____ |
| 63              | KEEP CREDIT (ON/OFF)   | ON                  | _____                                    |
| 64              | KEEP MONEY (ON/OFF)  | ON                  | _____                                    |
| 65              | ALBUM SELECT (ON/OFF)  | ON                  | _____                                    |
| 66              | PRIORITY PLY (ON/OFF)  | ON                  | _____                                    |
| 67              | TRKS IN A ROW  | 2                   | _____                                    |
| 68              | KARAOKE (100 MAX) <sup>5</sup>   | ON                  | _____                                    |
|                 | <b>* MORE OPTIONS 1*</b>   |                     |  |
| 690             | PAID PLAY (FIFO/RAND)  | FIFO                | _____                                    |
| 691             | FREE PLAY (RAND/FIFO)  | RAND                | _____                                    |
| 692             | CLEAR TIME   | 240                 | _____                                    |
| 693             | LOCKOUT COUNT  | 99                  | _____                                    |
| 694             | PLAY LIMIT   | 0                   | _____                                    |
| 695             | CANCEL APLAY (ON/OFF)  | OFF                 | _____                                    |
| 696             | AP ONLY (25 MAX) <sup>5</sup>  | 00_____             | 00_____<br>01_____<br>02_____<br>03_____ |
| 697             | DAYLIT (STD/NONSTD/OFF)<br>DAYLIT ON (ONLY FOR NON STD)<br>DAYLIT OFF (ONLY FOR NON STD) | STD                 | _____<br>_____<br>_____                  |
| 698             | AUTOMAT CLR (ON/OFF)   | ON                  | _____                                    |
|                 | <b>* MORE OPTIONS 2*</b>   |                     |  |
| 6990            | TIM LOCK (25 MAX) <sup>5</sup>   | 00_____             | 00_____<br>01_____<br>02_____<br>03_____ |
| 6991            | LOCK SCH <sup>4</sup>  | SMTWTFS             | _____                                    |
| 6992            | FREE ALBUM ON/OFF  | OFF                 | _____                                    |
| 6993            | "THANK YOU" ON/OFF   | ON                  | _____                                    |
| 6994            | POPULAR KEY  | ON                  | _____                                    |
| 6995            | PREMIUM RATIO  | 2                   | _____                                    |
| 6996            | AUTOLOD DFLT   | OFF                 | _____                                    |
| 6998            | SEL ----   | 00:00               | _____                                    |
| 6999            | PAIR SEL (10 MAX) <sup>5</sup>   | 00_____             | 00_____<br>01_____<br>02_____<br>03_____ |



| MENU<br>COMMAND | MENU<br>NAME                           | FACTORY<br>SETTINGS | OPERATOR<br>CHANGES |
|-----------------|--|---------------------|---------------------|
|                 | <b>* REPORTS *</b>                     |                     |                     |
| 78              | BAUD RATE<br>(600/1200/2400/4800/9600) | 9600                | _____               |
|                 | CR MS DELAY                            | 0                   | _____               |
|                 | SPEC REPORT                            | 0                   | _____               |
|                 | <b>* DEVICE SETUP *</b>                |                     |                     |
| 92              | MAIN DISP LINE                         | 2                   | _____               |
| 93              | BGM DELAY TIME                         | 10                  | _____               |
| 94              | LEAD SINGER (LEFT/RIGHT)               | RIGHT               | _____               |
| 96              | AP VOLUME (OFF/SEPART/LOCKED)          | OFF                 | _____               |
| 97              | VOLUME OPTION                          | 10                  | _____               |
| 98              | VOLUME STEP                            | 2                   | _____               |
|                 | <b>* AMPLIFIER *</b>                   |                     |                     |
| 900             | CH1 MIC OVERR                          | 33                  | _____               |
| 901             | CH2 MIC OVERR                          | 33                  | _____               |
| 902             | CH3 MIC OVERR                          | 33                  | _____               |
| 903             | CH4 MIC OVERR                          | 33                  | _____               |
| 904             | MIC1 ROUT                              | 111111              | _____               |
| 905             | MIC2 ROUT                              | 111111              | _____               |
| 906             | MIC3 ROUT                              | 111111              | _____               |
| 907             | MIC TYP                                | 000111              | _____               |
| 908             | BGM MAX VOL                            | 63                  | _____               |
|                 | <b>* IR REMOTE *</b>                   |                     |                     |
| 911             | RMT SELECT (ON/OFF/ICD/XCD)            | OFF                 | _____               |
| 912             | RMT CREDIT                             | 0                   | _____               |
| 913             | RMT PAUSE (ON/OFF)                     | OFF                 | _____               |
| 914             | PAUSE TIME                             | 90                  | _____               |
| 915             | RMT APLY OVR (ON/OFF)                  | OFF                 | _____               |
| 916             | RMT RELOAD (0)                         | 0                   | _____               |
| 917             | RMT IN SEL (ON OFF)                    | OFF                 | _____               |
| 918             | IR CLEAR SEL (ON/OFF)                  | OFF                 | _____               |
|                 | <b>* MORE AMP 1 *</b>                  |                     |                     |
| 9090            | CD INPUT LVL                           | 34                  | _____               |
| 9091            | STEREO A LVL                           | 34                  | _____               |
| 9092            | STEREO B LVL                           | 34                  | _____               |
| 9093            | MONO LVL                               | 34                  | _____               |
| 9094            | OUTCH 1/2 LVL                          | 32                  | _____               |
| 9095            | OUTCH 3/4 LVL                          | 32                  | _____               |
| 9096            | EQUALIZ CH 1 & 2                       | 1E99999 2E99999     | _____               |
| 9097            | EQUALIZ CH 3 & 4                       | 3E99999 4E99999     | _____               |
|                 | <b>* MORE AMP 2 *</b>                  |                     |                     |
| 90990           | PLAY AU IN SEL                         | 5                   | _____               |
| 90991           | PLAY KA IN SEL                         | 5                   | _____               |
| 90992           | PLAY VI IN SEL                         | 5                   | _____               |
| 90993           | SBY IN SEL                             | 5                   | _____               |
| 90994           | BGM IN SEL                             | 5                   | _____               |
| 90995           | MIC IN SEL                             | 6                   | _____               |
| 90996           | AUD MUT                                | 11111111            | _____               |
| 90997           | KAR MUT                                | 11111111            | _____               |
| 90998           | VID MUT                                | 11111111            | _____               |



| MENU<br>COMMAND | MENU<br>NAME          | FACTORY<br>SETTINGS | OPERATOR<br>CHANGES |
|-----------------|-----------------------|---------------------|---------------------|
|                 | <b>* MORE AMP 3 *</b> |                     |                     |
| 909990          | SBY MUT               | 00000000            | _____               |
| 909991          | BGM MUT               | 00000000            | _____               |
| 909992          | MIC MUT               | 11111111            | _____               |
| 909993          | PLY AU MOD 1/2        | 5                   | _____               |
| 909994          | PLY AU MOD 3/4        | 5                   | _____               |
| 909995          | PLY KA MOD 1/2        | 5                   | _____               |
| 909996          | PLY KA MOD 3/4        | 5                   | _____               |
| 909997          | PLY VI MOD 1/2        | 5                   | _____               |
| 909998          | PLY VI MOD 3/4        | 5                   | _____               |
|                 | <b>* MORE AMP 4 *</b> |                     |                     |
| 9099990         | SBY OUTMOD 1/2        | 5                   | _____               |
| 9099991         | SBY OUTMOD 3/4        | 5                   | _____               |
| 9099992         | BGM OUTMOD 1/2        | 5                   | _____               |
| 9099993         | BGM OUTMOD 3/4        | 5                   | _____               |
| 9099994         | MIC OUTMOD 1/2        | 5                   | _____               |
| 9099995         | MIC OUTMOD 3/4        | 5                   | _____               |
| 9099996         | MSK1                  | 1111111111          | _____               |
| 9099997         | MSK2                  | 1111111111          | _____               |
| 9099998         | MSK3                  | 1111111111          | _____               |
| 9099999         | MSK4                  | 1111111111          | _____               |

<sup>1</sup> Time shows current time of day

<sup>2</sup> Date shows current month/day/year

<sup>3</sup> See *Enhanced Autoplay Tutorial*

<sup>4</sup> See *Timed Free Play and Timed Lockout Scheduling Tutorial*

<sup>5</sup> See *Programming Autoplay, Premium, Priorities, Lockouts, and Pairs*



## OPTIONAL STUDIO SOUND SYSTEM

### Introduction

The Studio Sound system can use one or two digital power amplifiers. Each 2-channel digital power amplifier is rated 1000 (500 x2) watts RMS @ 2 ohm load. The 4-channel Audio/Video Controller replaces the 2-channel preamplifier; and has 3 microphone jacks, many RCA jacks for easy connection and adaptability, and audio components for karaoke. The Volume Control Unit replaces the wired volume control and the IR 2-channel volume control, and controls volume of channels and microphones (see *Volume Control Unit*).

### Volume Control Unit

The Volume Control Unit on rear of phonograph displays and controls the volume of the amplifier channels and microphones, turns power ON/OFF (sleeping), rejects a selection playing, or adds a credit (same as IR remote credits). It also controls volume of the lead singer on karaoke CD's (see *Karaoke Controls*).

Channel volume is displayed when the mode LED is off, and microphone volume is displayed when the mode LED is on. The MODE key toggles between channels and microphones. Raise or lower the volume of the channel(s) or microphone using the UP DOWN keys. The volume range is 0 to 63.

The CH, MIC, and SINGER LED's indicate what volume is being displayed. When adjusting channel volume if more than one LED is on it means those channels have the same volume (i.e. they are locked together). All four channels are locked together when shipped from the factory (see service menu item 97 VOLUME OPTION for other possible configurations).

The Volume Control Unit can be removed from rear of phonograph and mounted remotely (behind bar, etc.). A plate to cover the hole is in the cash bag. You need to supply a 6-conductor modular (phone) cable (pin 1 to pin 6, pin 2 to pin 5, pin 3 to pin 4, pin 4 to pin 3, pin 5 to pin 6, pin 6 to pin 1). You can purchase cable(s) or parts to make you own from Radio Shack, Digi-Key, or other sources.

A total of 4 volume control units may be wired to a phonograph. Each volume control unit is assigned a different Rowelink address. The factory installed volume control unit (unit 1) is assigned address 0. Unit 2 would be assigned address 1, unit 3 address 2 and unit 4 address 3. To set the addresses for units 2, 3, 4, take the unit apart, and set the dip switches as follows:

Address 0 - Both switches OFF. (already assigned to unit 1)

Address 1 - Switch 1 OFF, Switch 2 ON

Address 2 - Switch 1 ON, Switch 2 OFF

Address 3 - Switch 1 ON, Switch 2 ON

Put the unit back together.



## Audio/Video Controller

### Description

The extremely versatile 4 channel Audio/Video Controller transforms audio signals from the CD player, microphones, background music equipment (tuner, tape, etc.), and other sound processors/equipment/systems, into signals for the Power Amplifier. Also, it has video and audio relays for interfacing your video requirements (karaoke, Video CD's, TV shows, etc.).

It has AVC (automatic volume control) to correct varying recording levels, and tone control via 5-band equalizers.

All adjustments and options are programmable and retained in the CCC.

### Microphones

Rowe microphones or low-level balanced/unbalanced microphones can be used. Up to 3 microphones can be connected and simultaneously used for paging and/or karaoke. Each microphone can be routed to any or all outputs. Factory setting sets all microphones for paging and routes all microphones to all outputs.

If a microphone is used for paging and music is playing the music volume is reduced at least 6 dB. The music volume can be reduced more by lowering the numbers programmed in menu items 900–903, mic volume override. The mic volume override number range is 0 to 63, and factory setting is 33.

### Background Music (BGM)

The phonograph goes to BGM mode after all phonograph selections are played. In BGM mode music can be provided by an external BGM unit (tapes, tuner, CD's, etc.).

***To use an external stereo BGM unit:*** connect to jacks marked STEREO A (BGM) INPUT, set menu item 90994 BGM SELECT IN to 4, and set menu item 909991 BGM MUT to 11111111.

***To use an external mono BGM unit:*** connect to jack marked MONO C (BGM) INPUT, set menu item 90994 BGM SELECT IN to 1, and set menu item 909991 BGM MUT to 11111111.

### BGM, AUTOPLAY, and PAID PLAY Volume

As shipped from the factory, the volume control treats AUTOPLAY, external BGM, and PAID PLAY the same. Menu item 96 allows PAID PLAY volume to be separate from AUTOPLAY and external BGM volume, or AUTOPLAY and external BGM volume to be locked at a volume. Menu item 908 sets a max volume level for AUTOPLAY and external BGM.

### Karaoke Controls

This phonograph has the audio components for Karaoke. Just add microphones, and install a Rowe CDG or CDV decoder kit compatible with the new electronics, for a complete Karaoke solution. The kit instructions tell how to setup and use the controls.

## Amplifier Factory Load

The AUDIO/VIDEO CONTROLLER has many programming options. For your convenience, service mode menu item 95 restores the amplifier programming to factory settings.

## Other Configurations

All the programming options and RCA jacks are covered in the audio block diagram, audio programming block diagram, and the menu and command descriptions. Many configurations are possible to satisfy your imagination and the location audio/video requirements.

If you have any questions, call the Rowe customer service department.

## Summary of Audio/Video Controller Features and Flow – Front to Back (ref: Audio Block Diagram)

- RCA jacks for Front End inputs
  - Jacks marked CD/Stereo Mechanism, Stereo A (BGM), Stereo B, Mono C (BGM)
- AVC corrects Front End signal for varying recording levels
- RCA jacks for Left and Right AUXILIARY OUT with AVC and PAGING
- Left and Right channels split into 4 channels
  - Left channel becomes channel 1 and channel 3
  - Right channel becomes channel 2 and channel 4
- Channels 1, 2, 3, and 4 are equalized. Each channel has its own 5-band equalizer.
- RCA jacks for connecting external sound processor, other sound systems, etc.
  - Jacks marked EQUALIZER OUT, and CH1 through CH4 INPUT
- RCA jacks for connecting AUX inputs
- Volume control for Channels 1, 2, 3, and 4. Each channel can be linked or separate
- Microphones
  - 3 microphones can be connected and used simultaneously
  - 1/4-inch jacks for balanced and unbalanced microphones, and headers for Rowe microphones
  - Each microphone can be routed to any or all 6 outputs (AUX L, AUX R, CH1, CH2, CH3, CH4)
  - Microphones can be used for paging and/or karaoke
- RCA jacks and video and audio relays for video CD's, karaoke, and location A/V (TV's, etc.)
  - Jacks marked AUDIO SWITCH and VIDEO SWITCH
- RCA jacks for connecting external sound processor, other sound systems, etc.
  - Jacks marked:
    - CH1 NON-INVERT SIGNAL, CH1 INVERT SIGNAL OUTPUT, CH1 SIGNAL OUTPUT
    - CH2 OUTPUT, CH2 SIGNAL OUTPUT
    - CH3 NON-INVERT SIGNAL, CH3 INVERT SIGNAL OUTPUT, CH3 SIGNAL OUTPUT
    - CH4 OUTPUT, CH4 SIGNAL OUTPUT

- RCA jacks for surround sound
  - Jacks marked:
    - CH1 - CH2 SIGNAL OUTPUT, CH1 + CH2 SIGNAL OUTPUT
    - CH3 - CH4 SIGNAL OUTPUT, CH3 + CH4 SIGNAL OUTPUT
- RCA jacks for back end signal outputs
  - Jacks marked:
    - CH1 SIGNAL OUTPUT, CH2 SIGNAL OUTPUT
    - CH3 SIGNAL OUTPUT, CH4 SIGNAL OUTPUT
    - CH1 and CH3 are inverted

This page intentionally left blank.

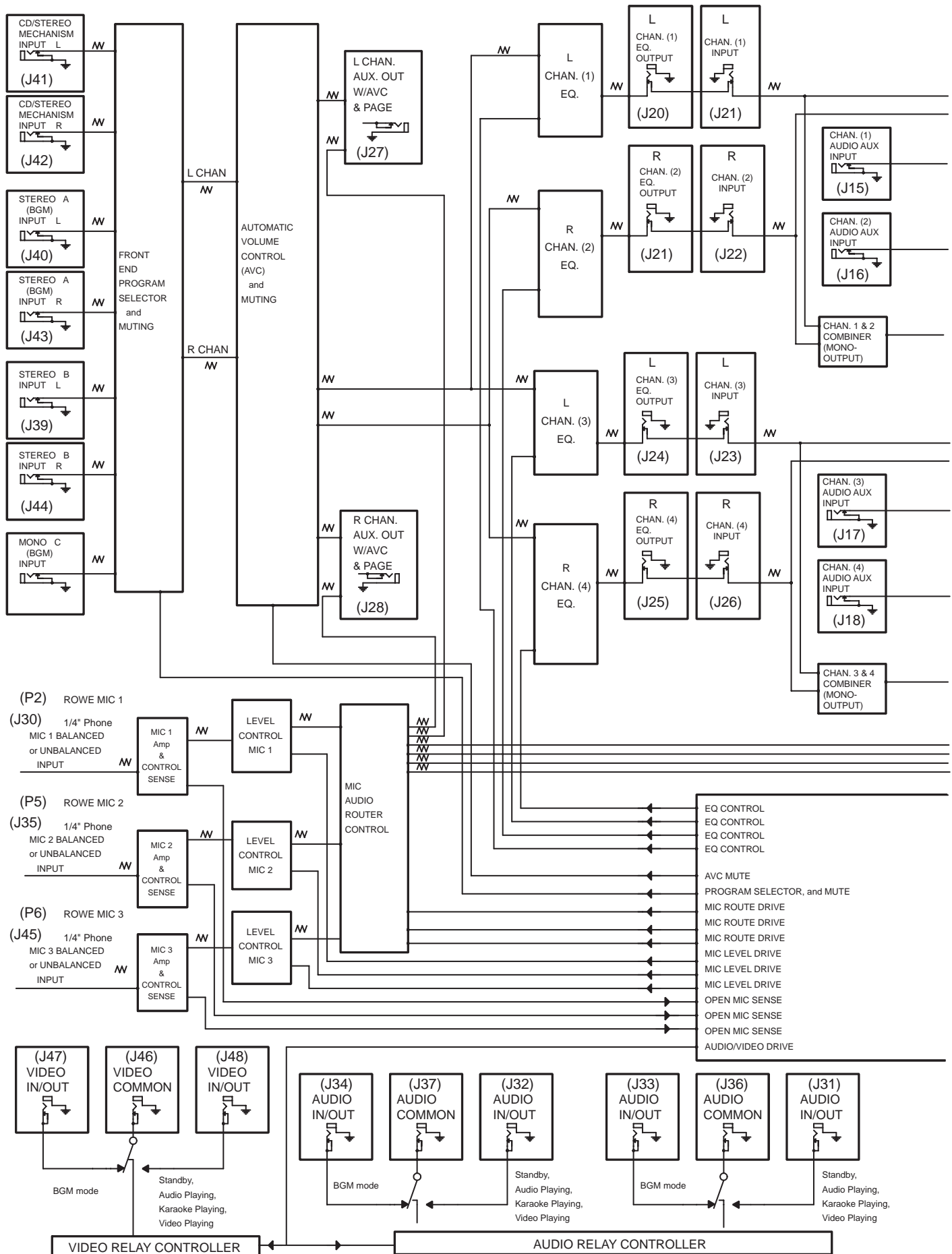

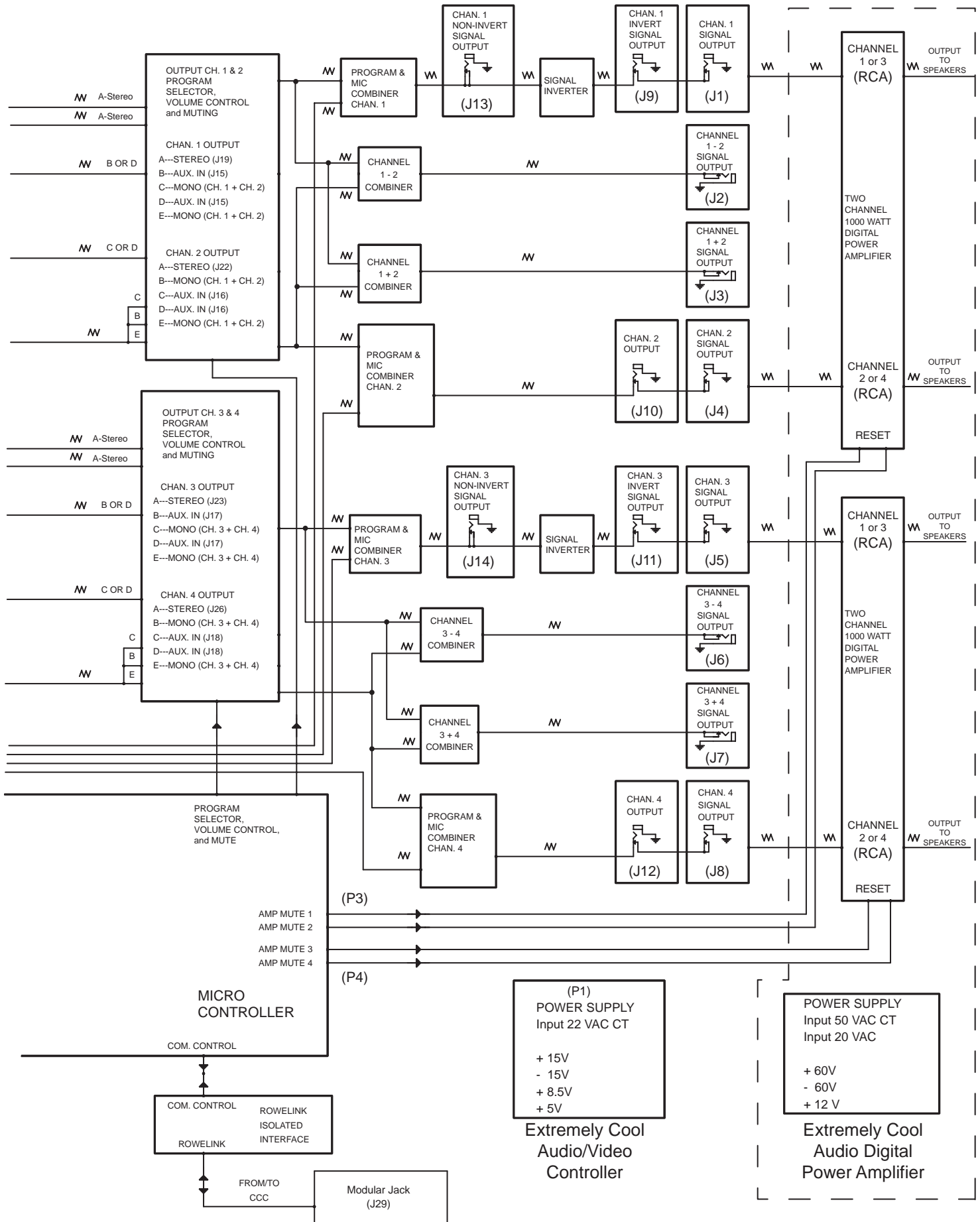

STUDIO SOUND AUDIO BLOCK DIAGRAM

**90993**  
**Front-end**  
**Program Selected**  
**in Standby Mode**  
 CD (J41, J42),  
 Stereo A (BGM) (J40, J43),  
 Stereo B (J39, J44),  
 Mono C (BGM) (J38)  
 Factory setting is CD (J41, J42)

**9099990**  
**Output Ch.1, and 2**  
**Program Selected**  
**in Standby Mode**  
 mono(CH1+CH2) / mono(CH1+CH2)  
 aux(J15) / aux(J16)  
 mono(CH1+CH2) / aux(J16)  
 aux(J15) / mono(CH1+CH2)  
 stereo(J19) / stereo(J22)  
 Factory setting is stereo/stereo

**9099991**  
**Output Ch.3, and 4**  
**Program Selected**  
**in Standby Mode**  
 mono(CH3 + CH4) / mono(CH3 + CH4)  
 aux(J17) / aux(J18)  
 mono(CH3 + CH4) / aux(J18)  
 aux(J17) / mono(CH3 + CH4)  
 stereo(J23) / stereo(J26)  
 Factory setting is stereo/stereo

**909990 Muting in Standby Mode**  
 Audio/Video Controller Out CH 3&4,  
 Audio/Video Controller Out CH 1&2,  
 Front End,  
 AVC,  
 Power Amp Out CH1,  
 Power Amp Out CH2,  
 Power Amp Out CH3,  
 Power Amp Out CH4  
 Factory Setting (00000000) mutes all

**90994**  
**Front-end**  
**Program Selected**  
**in BGM Mode**  
 CD (J41, J42),  
 Stereo A (BGM) (J40, J43),  
 Stereo B (J39, J44),  
 Mono C (BGM) (J38)  
 Factory setting is CD (J41, J42)

**9099992**  
**Output Ch.1, and 2**  
**Program Selected**  
**in BGM Mode**  
 mono(CH1 + CH2) / mono(CH1 + CH2)  
 aux(J15) / aux(J16)  
 mono(CH1 + CH2) / aux(J16)  
 aux(J15) / mono(CH1 + CH2)  
 stereo(J19) / stereo(J22)  
 Factory setting is stereo/stereo

**9099993**  
**Output Ch.3, and 4**  
**Program Selected**  
**in BGM Mode**  
 mono(CH3 + CH4) / mono(CH3 + CH4)  
 aux(J17) / aux(J18)  
 mono(CH3 + CH4) / aux(J18)  
 aux(J17) / mono(CH3 + H4)  
 stereo(J23) / stereo(J26)  
 Factory setting is stereo/stereo

**909991 Muting in BGM Mode**  
 Audio/Video Controller Out CH 3&4,  
 Audio/Video Controller Out CH 1&2,  
 Front End,  
 AVC,  
 Power Amp Out CH1,  
 Power Amp Out CH2,  
 Power Amp Out CH3,  
 Power Amp Out CH4  
 Factory Setting (00000000) mutes all

**908 BGM Volume Max**  
 Range is 0 to 63.  
 Factory setting is 63.

**93 BGM Delay Time**  
 Delay from Standby Mode to BGM Mode.  
 Factory setting is 10 seconds.

**96 Autoplay Volume**  
 Selects OFF, SEPARATE, or LOCKED for BGM, Autoplay, and Paid Play.  
 Factory setting is OFF.

The Standby Mode is active between plays, and after all sections are played until phonograph goes to BGM Mode.

The Playing Karaoke Mode is active when playing a Karaoke selection (MENU item 68).

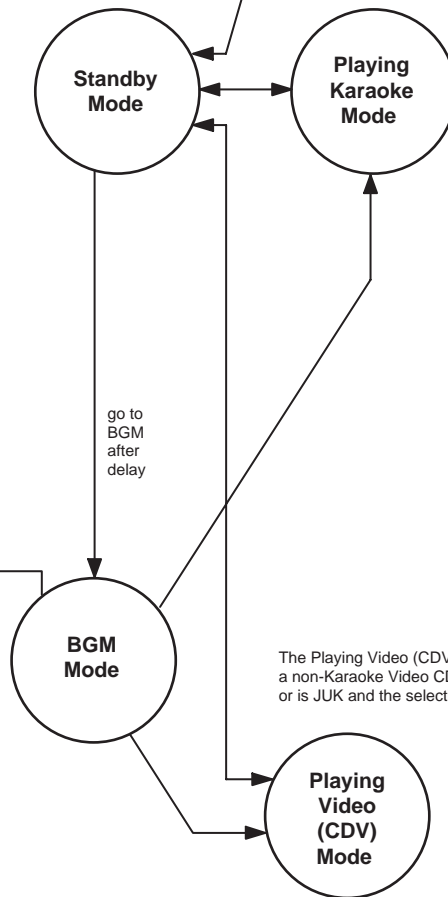

**90991**  
**Front-end**  
**Program Selected**  
**in Playing Karaoke Mode**  
 CD (J41, J42),  
 Stereo A (BGM) (J40, J43),  
 Stereo B (J39, J44),  
 Mono C (BGM) (J38)  
 Factory setting is CD (J41, J42)

**909995**  
**Output Ch.1, and 2**  
**Program Selected**  
**in Playing Karaoke Mode**  
 mono(CH1 + CH2) / mono(CH1 + CH2)  
 aux(J15) / aux(J16)  
 mono(CH1 + CH2) / aux(J16)  
 aux(J15) / mono(CH1 + CH2)  
 stereo(J19) / stereo(J22)  
 Factory setting is stereo/stereo

**909996**  
**Output Ch.3, and 4**  
**Program Selected**  
**in Playing Karaoke Mode**  
 mono(CH3 + CH4) / mono(CH3 + CH4)  
 aux(J17) / aux(J18)  
 mono(CH3 + CH4) / aux(J18)  
 aux(J17) / mono(CH3 + CH4)  
 stereo(J23) / stereo(J26)  
 Factory setting is stereo/stereo

**90997 Muting in Karaoke Mode**  
 Audio/Video Controller Out CH 3&4,  
 Audio/Video Controller Out CH 1&2,  
 Front End,  
 AVC,  
 Power Amp Out CH1,  
 Power Amp Out CH2,  
 Power Amp Out CH3,  
 Power Amp Out CH4  
 Factory Setting (11111111) unmutes all

The Playing Video (CDV) Mode is active when playing a non-Karaoke Video CD (MENU item 278 is ON, or is JUK and the selection is in the PRIORITY list MENU item 61).

**90992**  
**Front-end**  
**Program Selected**  
**in Playing Video Mode**  
 CD (J41, J42),  
 Stereo A (BGM) (J40, J43),  
 Stereo B (J39, J44),  
 Mono C (BGM) (J38)  
 Factory setting is CD (J41, J42)

**909997**  
**Output Ch.1, and 2**  
**Program Selected**  
**in Playing Video Mode**  
 mono(CH1 + CH2) / mono(CH1 + CH2)  
 aux(J15) / aux(J16)  
 mono(CH1 + CH2) / aux(J16)  
 aux(J15) / mono(CH1 + CH2)  
 stereo(J19) / stereo(J22)  
 Factory setting is stereo/stereo

**909998**  
**Output Ch.3, and 4**  
**Program Selected**  
**in Playing Video Mode**  
 mono(CH3 + CH4) / mono(CH3 + CH4)  
 aux(J17) / aux(J18)  
 mono(CH3 + CH4) / aux(J18)  
 aux(J17) / mono(CH3 + CH4)  
 stereo(J23) / stereo(J26)  
 Factory setting is stereo/stereo

**90998 Muting in Playing Video Mode**  
 Audio/Video Controller Out CH 3&4,  
 Audio/Video Controller Out CH 1&2,  
 Front End,  
 AVC,  
 Power Amp Out CH1,  
 Power Amp Out CH2,  
 Power Amp Out CH3,  
 Power Amp Out CH4  
 Factory Setting (11111111) unmutes all

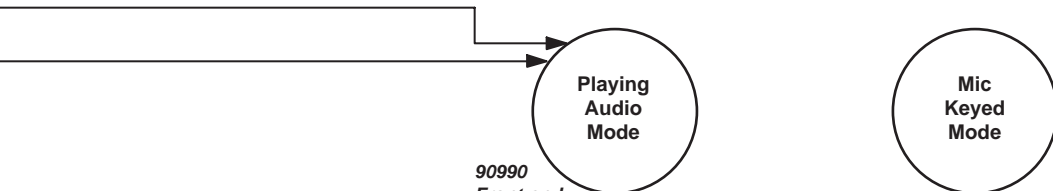

**90990**  
**Front-end**  
**Program Selected**  
**in Playing Audio Mode**  
 CD (J41, J42),  
 Stereo A (BGM) (J40, J43),  
 Stereo B (J39, J44),  
 Mono C (BGM) (J38)  
 Factory setting is CD (J41, J42)

**909993**  
**Output Ch. 1, and 2**  
**Program Selected**  
**in Playing Audio Mode**  
 mono(CH1 + CH2) / mono(CH1 + CH2)  
 aux(J15) / aux(J16)  
 mono(CH1 + CH2) / aux(J16)  
 aux(J15) / mono(CH1 + CH2)  
 stereo(J19) / stereo(J22)  
 Factory setting is stereo/stereo

**909994**  
**Output Ch. 3, and 4**  
**Program Selected**  
**in Playing Audio Mode**  
 mono(CH3 + CH4) / mono(CH3 + CH4)  
 aux(J17) / aux(J18)  
 mono(CH3 + CH4) / aux(J18)  
 aux(J17) / mono(CH3 + CH4)  
 stereo(J23) / stereo(J26)  
 Factory setting is stereo/stereo

**90996 Muting in Playing Audio Mode**  
 Audio/Video Controller Out CH 3&4,  
 Audio/Video Controller Out CH 1&2,  
 Front End,  
 AVC,  
 Power Amp Out CH1,  
 Power Amp Out CH2,  
 Power Amp Out CH3,  
 Power Amp Out CH4  
 Factory Setting (11111111) unmutes all

**90995**  
**Front-end**  
**Program Selected**  
**in Mic Keyed Mode**  
 CD (J41, J42),  
 Stereo A (BGM) (J40, J43),  
 Stereo B (J39, J44),  
 Mono C (BGM) (J38), Unchanged  
 Factory setting is CD (J41, J42)

**9099994**  
**Output Ch. 1, and 2**  
**Program Selected**  
**in Mic Keyed Mode**  
 mono(CH1 + CH2) / mono(CH1 + CH2)  
 aux(J15) / aux(J16)  
 mono(CH1 + CH2) / aux(J16)  
 aux(J15) / mono(CH1 + CH2)  
 stereo(J19) / stereo(J22)  
 Factory setting is stereo/stereo

**9099995**  
**Output Ch. 3, and 4**  
**Program Selected**  
**in Mic Keyed Mode**  
 mono(CH3 + CH4) / mono(CH3 + CH4)  
 aux(J17) / aux(J18)  
 mono(CH3 + CH4) / aux(J18)  
 aux(J17) / mono(CH3 + CH4)  
 stereo(J23) / stereo(J26)  
 Factory setting is stereo/stereo

**909992 Muting in Mic Keyed Mode**  
 Audio/Video Controller Out CH 3&4,  
 Audio/Video Controller Out CH 1&2,  
 Front End,  
 AVC,  
 Power Amp Out CH1,  
 Power Amp Out CH2,  
 Power Amp Out CH3,  
 Power Amp Out CH4  
 Factory Setting (11111111) unmutes all

**900 -903**  
**Mic Volume Override**  
**Ch 1, 2, 3, 4**  
 Range 0 to 63. Factory setting is 33.

**904 -906 Mic Routing**  
 Each mic can be routed to any  
 or all 6 channels.  
 Factory setting routes all mics to all  
 channels

**907 Mic Type**  
 Each mic can be a paging or karaoke type. Also,  
 sets phonograph type to CD or Download.  
 Factory setting sets all mic's to paging, and  
 phonograph type to CD.

**94 Lead Singer**  
 Sets karaoke lead singer to LEFT  
 or Right channel.  
 Factory setting is RIGHT

**ADDITIONAL PROGRAMMING**

**98 IR Volume Step**

Controls how fast the volume changes when using  
 IR remote to adjust volume. Range is 1 to 5.  
 Factory Setting is 2

**9099996-9099999 Volume Control Switch Mask**

Disable/enable individual switches when using multiple  
 volume control units. Factory setting is 1111111111  
 (all switches enabled).

**95 Amp Factory Load**

Loads Factory Setting for the amplifier

**9096 Equalizer Ch. 1,2 Two 5 band equalizers.**

**9097 Equalizer Ch. 3,4 Two 5 band equalizers.**

Range of each band is 0 to 9 Factory Setting is 1E99999 2E99999 3E99999 4E99999

**9090-9093 Attenuates or raises level of Front-end signal to fit into AVC range.**

Range is 0 to 50. Factory Setting is 34

**9094,9095 Attenuates or raises level of outputs to give 1V rms output when volume is 63 (maximum) and equalizers have factory settings.**

Range is 0 to 50. Factory Setting is 32.

**97 Volume Option. There are 10 different options. Factory setting is option 10.**

L, L1, L2 means those channels  
 volumes are locked together.  
 Changing the volume on any L, L1, or  
 L2 channel will also change the  
 volume on all like channels.

S means separate. Changing the  
 volume on a S channel will not affect  
 other channels.

| Option | CH1 | CH2 | CH3 | CH4 |
|--------|-----|-----|-----|-----|
| 1      | L1  | L1  | L2  | L2  |
| 2      | L   | L   | L   | S   |
| 3      | L   | L   | S   | L   |
| 4      | L1  | L1  | L2  | L2  |
| 5      | S   | L   | L   | L   |

| Option | CH1 | CH2 | CH3 | CH4 |
|--------|-----|-----|-----|-----|
| 6      | L   | L   | S   | S   |
| 7      | S   | S   | L   | L   |
| 8      | S   | S   | S   | S   |
| 9      | L1  | L2  | L1  | L2  |
| 10     | L   | L   | L   | L   |

**STUDIO SOUND AUDIO PROGRAMMING BLOCK DIAGRAM**



### How to remote the Volume Control Unit using existing 3-wire cable

CD-100K Phonograph

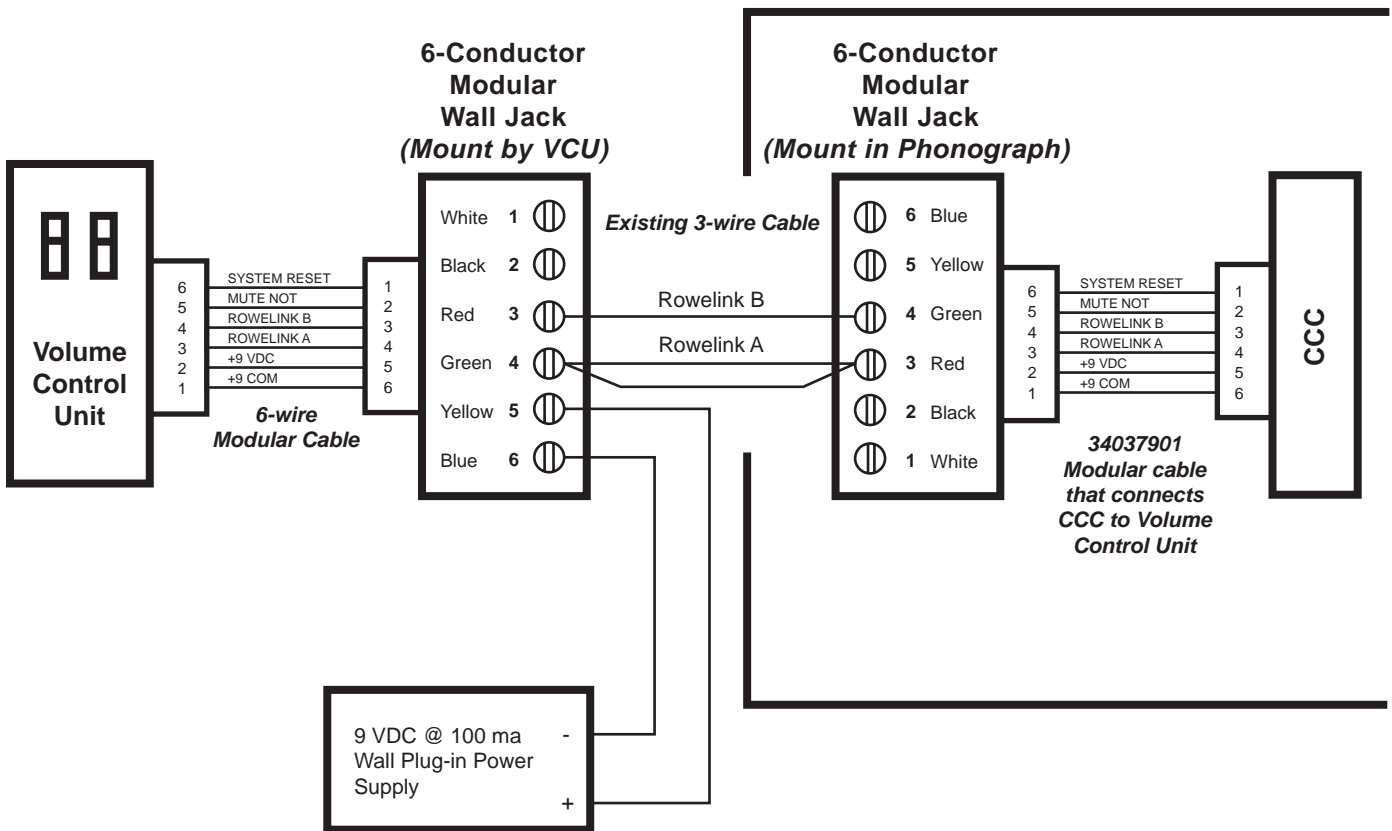

### How to remote the Volume Control Unit using existing 4-wire cable

CD-100K Phonograph

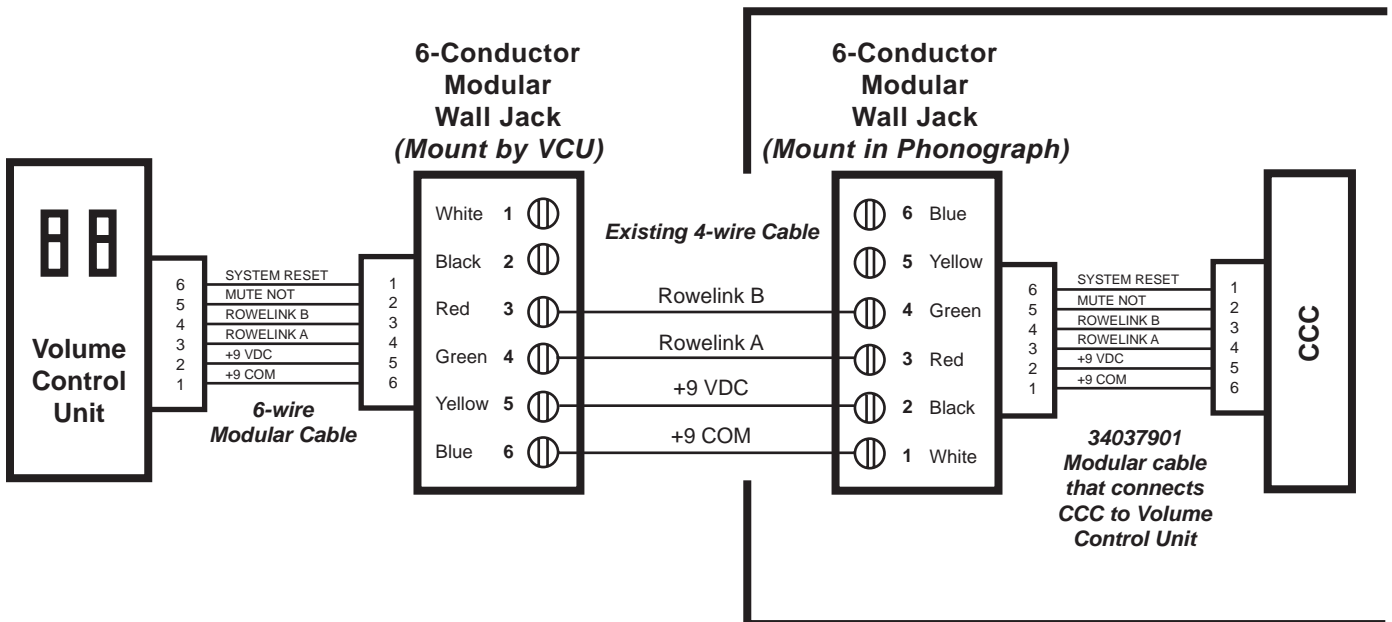

## Section 3: Routine Service

### INTRODUCTION

Routine and preventive maintenance are to be performed on your normal periodic service call. This section discusses how to change compact discs and titles, how to collect money, audit statistics, and preventive maintenance procedures.

### DOING AN AUDIT

The following pages describe how to:

1. Access the phonograph's audit menus and extract audit figures
2. Change title strips and discs
3. Collect money

You can perform these three activities in any order that you wish.

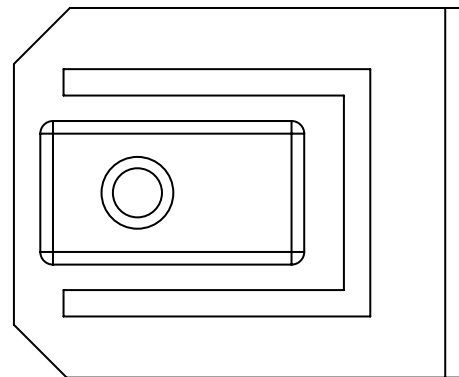

Figure 3-1. Service Switch

### COLLECTING AUDIT FIGURES

Following are descriptions of the major auditing activities that need to be done on a routine service call. If you wish to do additional auditing, you can obtain the additional commands from *Table 3-1*, the AUDIT commands.

#### Entering the Service Mode

1. Open the door and pull the SERVICE button (*Figure 3-1*) out to the SERVICE position. The phonograph display will read \* SERVICE MODE \*.



#### NOTE:

If you find that you are not seeing the display that you expect, press and hold RESET, then press POPULAR three times. This will take you back to the main menu.

At this point you can begin performing the audits. Refer to the *CD-100K Service Mode Map (Figure 2-10)* for a diagram of the audit menus and commands. Described here also are the procedures for clearing the audit values.

## Cash Audits

1. Type 100. This displays the CURRENT CASH value. Record the CURRENT CASH figure in your usual way and go to the next step.
2. Press and hold RESET, and then press 1. This will move you down to the next display. Record the CASH VALUE in the usual way.
3. Repeat *Step 2* until you do the last CASH audit, which is the #2 BILLS audit. Do this audit, then press and hold RESET while you press POPULAR three times.

## Play Audits

1. Type 110. This displays the FREE CREDITS value. Record the FREE CREDITS figure in your usual way and go to the next step.
2. Press and hold RESET, and then press 1. This will move you down to the next display. Record the credit value in the usual way.
3. Repeat *Step 2* until you do the last PLAY audit, which is the OVERPLAY audit. Do this audit, then press and hold RESET while you press POPULAR three times.

## Non-Resettable Audits

1. Type 120. This displays the NON-RESETTABLE CASH value. Record the NON-RESETTABLE CASH value in your usual way and go to the next step.
2. Press and hold RESET, and then press 1. This will move you down to the next display. Record the value in the usual way.
3. Repeat *Step 2* until you do the last NON-RESETTABLE audit, which is the SELS audit. Do this audit, then press and hold RESET while you press POPULAR three times. This returns you to the main menu.

## Most Popular Disc

1. Type 17. The most popular disc number will be displayed.
2. If you wish to know the next-to-the-most popular disc, press and hold RESET, and then press 3. Press and hold RESET, then press 3 to display each successive "Most Popular" disc. Press and hold RESET, then press 2 to move through the popularity display toward the most popular disc.
3. Press and hold RESET while you press POPULAR twice. This returns you to the main menu.

## Least Popular Disc

1. Type 18. The least popular disc will be displayed.
2. To display the next least popular disc, press and hold RESET and then press 2. Press and hold RESET, then press 2 to display each successive least popular disc. Press and hold RESET, then press 3 to move through the popularity display toward the least popular disc.

3. Press and hold RESET while you press POPULAR twice. This returns you to the main menu.

### Most Popular Selection

1. Type 19. The most popular selection number will be displayed.
2. To display the next most popular selection, press and hold RESET, and then press 3. Press and hold RESET, and then press 3 to display each successive most popular selection. Press and hold RESET, then press 2 to move through the popularity display toward the most popular selection.

You can request the popularity for a particular selection by pressing the selection number (four digits).

### Clearing the Audit Values

The three CLEAR options will not clear the corresponding audit value until the POPULAR button is pressed.

#### For example:

You can display the CLEAR CASH message and then move to CLEAR PLAYS and then move back to CLEAR CASH without actually clearing either set of values.

The following steps describe how to perform each of the three CLEAR commands as a separate activity. If you wish to use the “short cut” method, follow the *Using the CD-100K Commands* instructions in Section 2. Each of these commands may be executed from SECURITY LEVEL 2 or 3.

#### CLEAR CASH

1. Make sure that you are in the SERVICE mode and that \* SERVICE MODE \* is on the display.
2. Type 14. The message CLEAR CASH will appear on the display. Press POPULAR to clear the cash values. The display will blink when the command is executed.
3. Press and hold RESET while you press POPULAR twice.

#### CLEAR PLAYS

1. Make sure that you are in the SERVICE mode and that \* SERVICE MODE \* is on the display.
2. Type 15. The message CLEAR PLAYS will appear on the display. Press POPULAR to clear the play values. The display will blink when the command is executed.
3. Press and hold RESET while you press POPULAR twice.

#### CLEAR SELECTION POPULARITY

1. Make sure that you are in the SERVICE mode and that \* SERVICE MODE \* is on the display.
2. Type 16. The message CLEAR SEL POP will appear on the display. Press POPULAR to clear the popularity values. The display will blink when the command is executed.
3. Press and hold RESET while you press POPULAR twice.

## CHANGING CD'S AND TITLES



### NOTE:

Do not attempt to turn the CD title pages by hand. If the title page assembly is unplugged or not operating electronically, use the handwheel on the back of the assembly (see *Figure 1-2*).

The procedure for loading CD's and titles into an empty phonograph is different from the procedure to change CD's and titles. Please be sure you are following the procedure that describes your situation.

### Preparing Titles for the Title Holder - See Pages 2-2 thru 2-5

#### Changing Discs

You can (1) initialize each disc as you change it, or (2) you can write down all of the disc numbers and then type them all into the INITIALIZE command. The following steps describe the second method.

Change discs as follows:

1. Unlock and open the door.
2. Pull the SERVICE switch out to the SERVICE position (refer to *Figure 3-1*).
3. Press the SCAN button to move the disc space to the left or right of the transfer arm.
4. Slide the old CD out of the slot and slide the new CD into the slot (see *Figure 3-2*) with the label to the right. Write the disc number on a note pad.

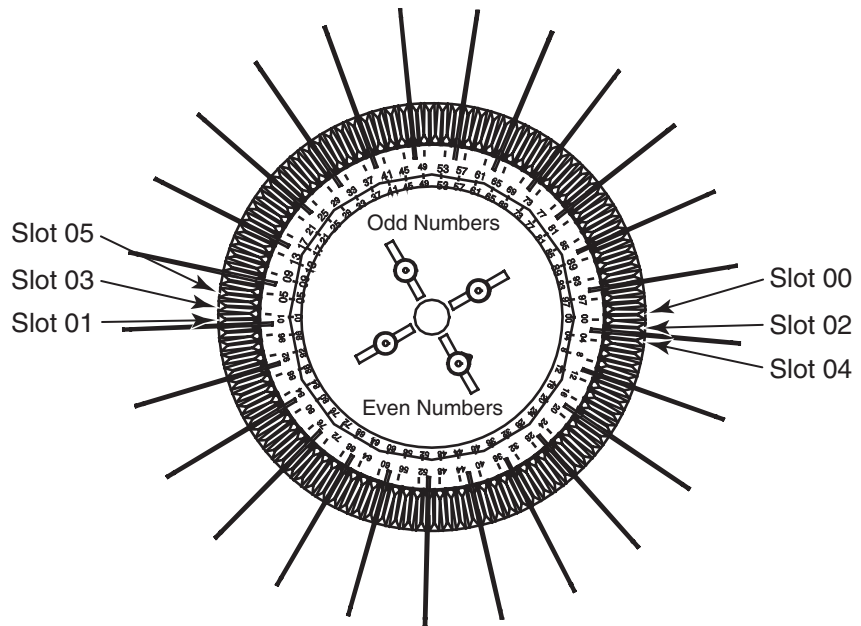

**Figure 3-2. Loading the Molded CD Magazine**

Note that the disc positions in the molded CD magazine are identified by numbers at every other slot, with even numbered slots labeled on one half of the magazine, and odd numbered slots labeled on the other half.

For example, on the even numbered half of the magazine, slots 00, 04, and 08 are labeled, and the slots in between – 02 and 06 – are not, as illustrated in *Figure 3-2*.

**NOTE:**

When loading the magazine, be sure the disc rests in the same numbered slot in both the front and rear of the magazine. Be sure to keep the magazine disc load approximately balanced. If the magazine is partially loaded with all discs on one side, the sprag wheel may lock and the magazine will not turn.

5. Repeat *Step 4* until all discs have been changed.
6. Release the two catches holding the keyboard/display.
7. Place the SERVICE switch in the SERVICE mode and check that \* SERVICE MODE \* is on the keyboard display.
8. Type 31 and the display will show PROGRAMINIT --. Enter the CD numbers that you have changed and press POPULAR after each number. After you have entered all of the disc numbers, place the phonograph into the NORMAL mode and the initialization process will start. Selections can be made while the new discs are being initialized.

## COMPLETE AUDIT COMMAND LIST

Table 3-1 is a complete list of the Audit commands with an explanation of what each command does.

**Table 3-1. Audit Commands**

| Command                                  | Description   |
|--|---|
| <b>1 AUDITS</b>                          | - Are the functions and menus that allow you to display and reset the various accumulated figures for money, popularity, number of plays, and credits.  |
| <b>10 CASH AUDITS</b>                    | - Is the menu that allows you to display, but not change, cash totals, number of coins through the coin switches, and the total number of bills.  |
| <b>11 PLAY AUDITS</b>                    | - Is the menu that allows you to display, but not change, credits, autoplays, mechanism plays, and album plays.   |
| <b>12 NON-RESETTABLES</b>                | - Is the menu that allows you to display the ongoing totals. These totals cannot be reset from any security level.  |
| <b>13 Clear Disc Popularity</b>          | - Clears the popularity for all discs. This option should only be used after the popularity figures (Selections 7 and 8 in this menu) have been read and recorded. Press POPULAR to perform this function. The display will blink when the command is executed.   |
| <b>14 Clear Cash</b>                     | - Clears all current cash totals. This option should only be used after the figures for Cash Audits (Selection 0 in this menu) have been read and recorded. Press POPULAR to perform this function. The display will blink when the command is executed.  |
| <b>15 Clear Plays</b>                    | - Clears all current play totals. This option should only be used after the Play Audit figures in Play Audits (Selection 1 in this menu) have been read and recorded. Press POPULAR to perform this function. The display will blink when the command is executed.  |
| <b>16 Clear Selection Popularity</b>     | - Clears all current selection popularity. This option should only be used after Popularity Figures (Selection 9 in this menu) have been read and recorded. Press POPULAR to perform this function. The display will blink when the command is executed.  |
| <b>17 Display the Most Popular Disc</b>  | - Displays the most popular disc number (00-99) followed by the number of plays (9999 maximum) that disc had. To display the next Most Popular disc, press and hold RESET and then press 3. Press and hold RESET and then press 3 to display each successive most popular disc. Press and hold RESET and then press 2 to move up through the popularity display toward the most popular disc. You can request the popularity for a particular disc by pressing the disc number. |
| <b>18 Display the Least Popular Disc</b> | - Displays the least popular disc number (00-99) followed by the number of plays that the disc had. To display the next Least Popular disc, press and hold RESET and then press 2. Press and hold RESET and then press 2 to display each successive least popular disc. Press and hold RESET and then press 3 to move up through the popularity display toward the least popular disc. You can request the popularity for a particular disc by pressing the disc number.        |

**Table 3-1. Audit Commands**  
Continued

| Command    | Description   |
|------------|---|
| <b>19</b>  | <b>Display the Most Popular Selection</b> - Displays the most popular selection number (Disc 00-99 followed by Selection 00-99, a total of four digits) followed by the number of plays (9999 maximum) that selection had. To display the next Most Popular selection, press and hold RESET and then press 3. Press and hold RESET and then press 3 to display each successive most popular selection. Press and hold RESET and then press 2 to move up through the popularity display toward the most popular selection. A total of 100 selection numbers may be contained in the MOST POPULAR list. You can request the popularity for a particular selection by pressing the selection number (four digits). |
| <b>10</b>  | <b>CASH AUDITS</b> - Allows you to display, but not change, cash totals, number of coins through the coin switches, and the total number of bills.  |
| <b>100</b> | <b>Current Cash</b> - Displays the total amount of bill and coin money collected since the last time the CLEAR CASH command (Selection 4 in the AUDITS menu) was used.  |
| <b>101</b> | <b>Current Bill</b> - Displays the total amount of bill money collected since the last time the CLEAR CASH command (Selection 4 in the AUDITS menu) was used.   |
| <b>102</b> | <b>Current Coin</b> - Displays the total amount of coin money collected since the last time the CLEAR CASH command (Selection 4 in the AUDITS menu) was used.   |
| <b>103</b> | <b>Current Wallbox</b> - Displays the total amount of money collected by Wallboxes since the last time the CLEAR CASH command (Selection 4 in the AUDITS menu) was used.  |
| <b>104</b> | <b>Current Number of Type 1 Coins</b> - Displays the total number of Type 1 coins (5¢) collected since the last time the CLEAR CASH command (Selection 4 in the AUDITS menu) was used.  |
| <b>105</b> | <b>Current Number of Type 2 Coins</b> - Displays the total number of Type 2 coins (10¢) collected since the last time the CLEAR CASH command (Selection 4 in the AUDITS menu) was used.   |
| <b>106</b> | <b>Current Number of Type 3 Coins</b> - Displays the total number of Type 3 coins (25¢) collected since the last time the CLEAR CASH command (Selection 4 in the AUDITS menu) was used.   |
| <b>107</b> | <b>Current Number of Type 4 Coins</b> - Displays the total number of Type 4 coins (50¢) collected since the last time the CLEAR CASH command (Selection 4 in the AUDITS menu) was used.   |
| <b>108</b> | <b>Number of Type 1 Bills</b> - Displays the total number of Type 1 bills (\$1) collected since the last time the CLEAR CASH command (Selection 4 in the AUDITS menu) was used. (Menu Item 509 must be BILL if coin SW 6 used as Bill input.)   |
| <b>109</b> | <b>Number of Type 2 Bills</b> - Displays the total number of Type 2 bills (\$5) collected since the last time the CLEAR CASH command (Selection 4 in the AUDITS menu) was used. (Menu Item 509 must be BILL if coin SW 6 used as Bill input.)   |



**Table 3-1. Audit Commands**  
*Continued*

| Command                                   | Description  |
|---|--|
| <b>11 PLAY AUDITS</b>                     | Allows you to display, but not change, credits, autoplays, mechanism plays, and album plays.   |
| <b>110 Free Credits</b>                   | Displays the number of free credits given since the last time the CLEAR PLAYS command (Selection 5 in the AUDITS menu) was used.   |
| <b>111 Paid Credits</b>                   | Displays the number of paid credits given since the last time the CLEAR PLAYS command (Selection 5 in the AUDITS menu) was used.   |
| <b>112 Autoplays</b>                      | Displays the number of Autoplays made since the last time the CLEAR PLAYS command (Selection 5 in the AUDITS menu) was used.   |
| <b>113 Mechanism Plays</b>                | Displays the number of times the mechanism has played CD's since the last time the CLEAR PLAYS command (Selection 5 in the AUDITS menu) was used.  |
| <b>114 Album Buys</b>                     | Displays the number of times albums have been bought since the last time the CLEAR PLAYS command (Selection 5 in the AUDITS menu) was used.  |
| <b>115 Most Popular Plays</b>             | Displays the number of times that the POPULAR button was used to select the most popular selection since the last time the CLEAR PLAYS command (Selection 5 in the AUDITS menu) was used.  |
| <b>116 Normal Selections</b>              | Displays the number of selections made from the keyboard.  |
| <b>117 Overplay Counter</b>               | Displays the number of overplays selected since the last time the CLEAR PLAYS command (Selection 5 in the AUDITS menu) was used. The overplay counter is part of the CCC's memory, which keeps track of how many duplicate selections were made. A selection is considered to be a duplicate if it has been entered, but the CCC has not sent the selection number to the CD mechanism controller. |
| <b>118 Current Number of Type 5 Coins</b> | Displays the total number of Type 5 coins collected since the last time the CLEAR CASH command (Selection 4 in the AUDITS menu) was used.  |
| <b>119 Current Number of Type 6 Coins</b> | Displays the total number of Type 6 coins collected since the last time the CLEAR CASH command (Selection 4 in the AUDITS menu) was used. (Menu Item 509 must be COIN if coin SW 6 used as coin input.)  |
| <b>12 NON-RESETTABLES</b>                 | These totals for cash, plays, and credits can be displayed from any security level, but they cannot be reset from any security level. These totals constitute the permanent phonograph history.  |
| <b>120 Cash</b>                           | Displays total cash (bill and coin) received by the phonograph.  |
| <b>121 Bill</b>                           | Displays total bill cash received by the bill acceptor.  |

**Table 3-1. Audit Commands**  
*Continued*

| <b>Command</b>          | <b>Description</b>   |
|-------------------------|--|
| <b>122 Coin</b>         | - Displays total coin cash received by the coin acceptor.                            |
| <b>123 Wallbox</b>      | - Displays total cash received by all Wallboxes.                                     |
| <b>124 Free</b>         | - Displays total free credits.   |
| <b>125 Paid</b>         | - Displays total paid for credits.   |
| <b>126 Most Popular</b> | - Displays the total number of Most Popular selections made with the POPULAR button. |
| <b>127 Mechanism</b>    | - Displays the total number of mechanism cycles.                                     |
| <b>128 Album</b>        | - Display total album buys.  |
| <b>129 Selections</b>   | - Displays the total number of selections made using the keyboard.                   |

## COLLECTING MONEY

1. Open the top door and unlock the bill acceptor bill box by reaching in behind the bill acceptor.
2. Remove the currency, then close and lock the bill box.
3. Close the top door.

## PREVENTIVE MAINTENANCE

Preventive maintenance should be performed at the regular intervals specified, while adjustments should be made only when necessary.

In addition to cleaning the cabinet each time the location is visited, clean the interior every three to six months, as required. Keeping the cabinet interior clean reduces dust, resulting in increased disc and component life (*see the table below for cleaning details*).

- Use a vacuum cleaner to remove heavy dust deposits.
- Use a clean, lint-free cloth saturated in denatured alcohol to clean mechanical parts.
- Clean electrical parts using a clean, dry cloth or camel's hair brush.



### WARNING:

Use solvents in a well-ventilated area only. Do not use solvents on plastic parts.

| Action Required                          | Procedure  |
|--|--|
| 1. Clean Glass                           | a. Clean all glass with a paper towel and a non-abrasive cleaner.<br>b. Dry with a clean, lint-free cloth.   |
| 2. Clean painted wood and metal surfaces | a. Clean all painted wood and metal surfaces with mild soap and water.<br>DO NOT USE SOLVENTS.<br>b. Apply a good quality auto or furniture wax to protect the finish. |
| 3. Clean plastic trim                    | Wipe all plastic surfaces with a damp or dry cloth only. DO NOT USE SOLVENTS.  |
| 4. Clean electrical components           | Clean all electrical components with a clean, dry, lint-free cloth or soft-bristle brush only.   |

## CD Player Laser Lens

The CD player laser lens can collect dust, dirt, and smoke. These deposits can cause various intermittent problems that may, in time, become more severe. To avoid these problems, we recommend that you clean the laser lens occasionally. This interval can be as often as every other month, or less in some locations. Follow this procedure to safely clean the laser lens:



### NOTE:

Before you clean the laser lens, be sure to turn the jukebox power OFF and ground yourself by touching a grounded component (such as the BA) to discharge any static buildup that may harm the CD player.

1. Remove loose particles from the lens by gently brushing it with a camel's hair brush or a blow brush (both items can be purchased at most camera supply stores). Brush in the direction of the arrows shown in *Figure 3-3*. Take care not to snag brush bristles under the lens. The lens is mounted on a delicate suspension spring that may be damaged with even a soft brush.
2. Remove any remaining dirt by placing one to three drops of Kodak Lens Cleaner (Kodak Catalog Number 176 7136, available from photographic supply stores or Rowe 21966601) on a lint-free "Q"-Tip and very gently wiping dust and smoke deposits from the lens. Wipe in the direction of the arrows shown in *Figure 3-3*. Take care not to damage the delicate lens suspension spring. Do not allow any of the lens cleaner to run down the side of the lens.

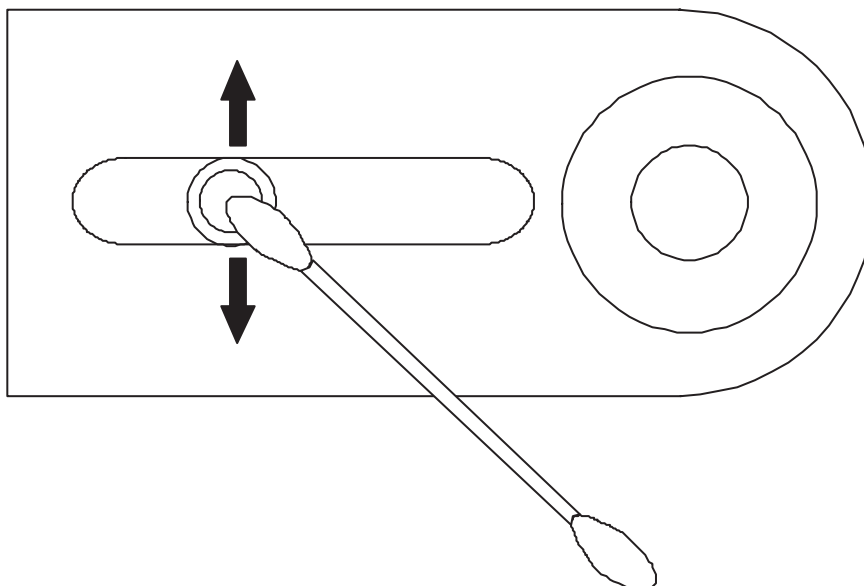

Figure 3-3. Cleaning the Laser Lens

## COIN ACCEPTORS (Optional)

### COIN MECH (Optional)

The phonograph is equipped to physically mount a 3.5 inch wide (80mm) coin acceptor, mechanical or electronic version, with an accepted coin diameter from .7 (18mm) to 1.2818 (31mm).

#### Mechanical

A valid coin is determined by the actuation of the microswitch (*Figure 3-4*), which when tripped will give a credit of 25 cents (unless the software default is changed).

The switch is mounted to a chute subassembly that guides the coins to the microswitch lever. By moving the #8-32 screw and the spacer, the microswitch is able to be actuated by coins of .7 inches (18mm) in diameter to 1.312 (33mm).

#### Electronic

The electronic coin acceptors make the phonograph capable of handling up to 6 different coins. A Mars 330 with a dual-polarity interface requires a 22160102 kit.

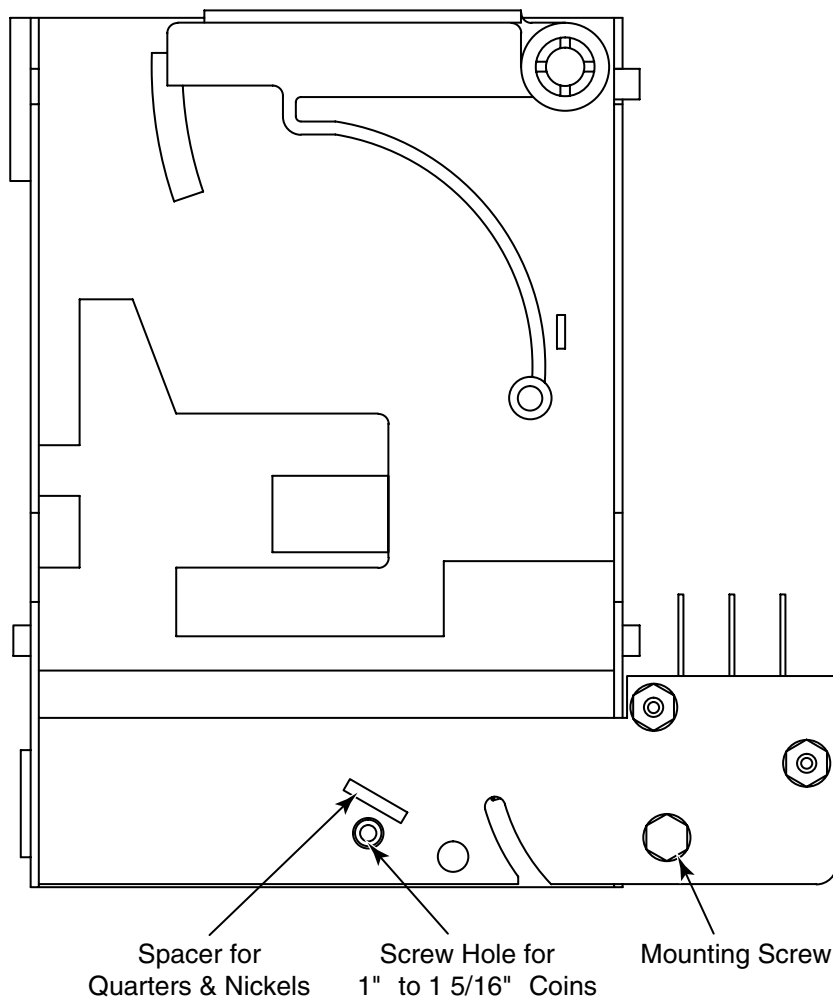

**Figure 3-4. Coin Switch**